



TROVE™

Access & Power Integration

T1SAK3F4

4 Door Kit with Fused Outputs

Fully assembled kit includes:

- Trove1 enclosure with TSA1 Altronix/Salto backplane
- (1) eFlow6NB - Power Supply/Charger
- (1) ACM4 - Fused Access Power Controller
- (1) VR6 - Voltage Regulator
- (1) PDS8 - Dual Input Power Distribution Module

T2SAK7F8

8 Door Kit with Fused Outputs

Fully assembled kit includes:

- Trove2 enclosure with TSA2 Altronix/Salto backplane
- (1) eFlow104NB - Power Supply/Charger
- (1) ACM8 - Fused Access Power Controller
- (1) VR6 - Voltage Regulator
- (1) PDS8 - Dual Input Power Distribution Module

T2SAK75F12

12 Door Kit with Fused Outputs

Fully assembled kit includes:

- Trove2 enclosure with TSA2 Altronix/Salto backplane
- (1) eFlow104NB - Power Supply/Charger
- (1) eFlow102NB - Power Supply/Charger
- (1) ACM8 - Fused Access Power Controller
- (1) ACM4 - Fused Access Power Controller
- (1) PDS8 - Dual Input Power Distribution Module

All components of these Trove kits are UL Listed sub-assemblies.

Please refer to the included corresponding Sub-Assembly Installation Guides for further information.

Installation Guide



More than just power.™

All registered trademarks are property of their respective owners.

Rev. TSAK032919

Installing Company: _____ Service Rep. Name: _____

Address: _____ Phone #: _____

Overview:

Altronix Trove Salto kits are pre-assembled and consist of Trove1SA1 or Trove2SA2 enclosure/backplane with factory installed Altronix power supply/charger(s) and sub-assemblies. These kits also accommodate various combinations of Salto modules for up to twelve (12) doors in a single enclosure.

Configuration Chart:



Altronix Model Number	120V AC 60Hz Input Current (A)	Power Supply Board Input Fuse Rating	Power Supply Board Battery Fuse Rating	Nominal DC Output Voltage				Maximum Supply Current for Main and Aux. Outputs on Power Supply board and ACM4/ACM8 Access Power Controller's outputs	Fail-Safe/Fail-Secure or Dry Form "C" Outputs	Current Per ACM4/ACM8 Output (A)	ACM4/ACM8 Board Input Fuse Rating	ACM4/ACM8 Board Output Fuse Rating	PDS8 Board Input Fuse Rating	PDS8 Board Output Fuse Rating
				Power Supply 1		Power Supply 2								
				[DC]	[Aux]	[DC]	[Aux]							
				Output Range (VDC)	Output Range (VDC)	Output Range (VDC)	Output Range (VDC)							
T1SAK3F4	3.5	5A/250V	10A/32V	20.19-26.4	20.19-26.4	-	-	24VDC @ 5.6A	4	2.5	10A/250V	3A/250V	10A/250V	3A/250V
T2SAK7F8	4.5	6.3A/250V	15A/32V	20.17-26.4	20.28-26.4	-	-	24VDC @ 9.2A	8	2.5	10A/250V	2.5A/250V	10A/250V	3A/250V
T2SAK75F12	8	6.3A/250V 5A/250V	15A/32V	20.17-26.4	20.28-26.4	10.03-13.2	10.03-13.2	12VDC @ 9.3A 24VDC @ 9.2A	12	2.5	10A/250V	2.5A/250V	10A/250V	3A/250V

Installation Instructions:

Wiring methods shall be in accordance with the National Electrical Code/NFPA 70/ANSI, and with all local codes and authorities having jurisdiction. Product is intended for indoor use only.

1. Remove backplane(s) from enclosure. Do not discard hardware.
2. Mark and predrill holes in the wall to line up with the top three keyholes in the enclosure. Install three upper fasteners and screws in the wall with the screw heads protruding. Place the enclosure's upper keyholes over the three upper screws, level and secure. Mark the position of the lower three holes. Remove the enclosure. Drill the lower holes and install the three fasteners. Place the enclosure's upper keyholes over the three upper screws. Install the three lower screws and make sure to tighten all screws.
3. Mount included UL Listed tamper switch (Altronix Model TS112 or equivalent) in desired location, opposite hinge. Slide the tamper switch bracket onto the edge of the enclosure approximately 2" from the right side (Fig. 1, pg. 2). Connect tamper switch wiring to the Access Control Panel input or the appropriate UL Listed reporting device. To activate alarm signal open the door of the enclosure.
4. Mount Salto modules to TSA2 backplane, refer to pg. 3, 4, 5.
5. Refer to the *eFlow Power Supply/Charger Installation Guide* eFlow6NB, eFlow102NB, eFlow104NB and corresponding *Sub-Assembly Installation Guides* for ACM4, ACM8, PDS8, VR6 for further installation instructions.

Hardware:

 Nylon Spacer  5/16" Pan Head Screw  Lock Nut

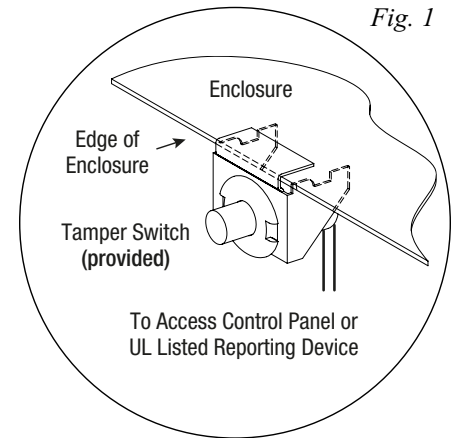

T1SAK3F4: Configuration of Salto Modules:

1. Fasten spacers onto metal pems configuration (A) of backplane (Fig. 2, pg. 3).
2. Position Salto modules over corresponding spacers and mount them utilizing pan head screws (provided) (Fig. 2a, pg. 3).
3. Mount backplane to enclosure with hardware.

Access Controller Position Chart for the Following Models:

Salto Access Controller	Pem Mounting
CU42E0, CU4200 or CU4EB8	(A)

Fig. 2

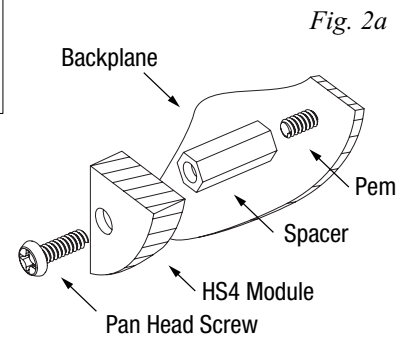
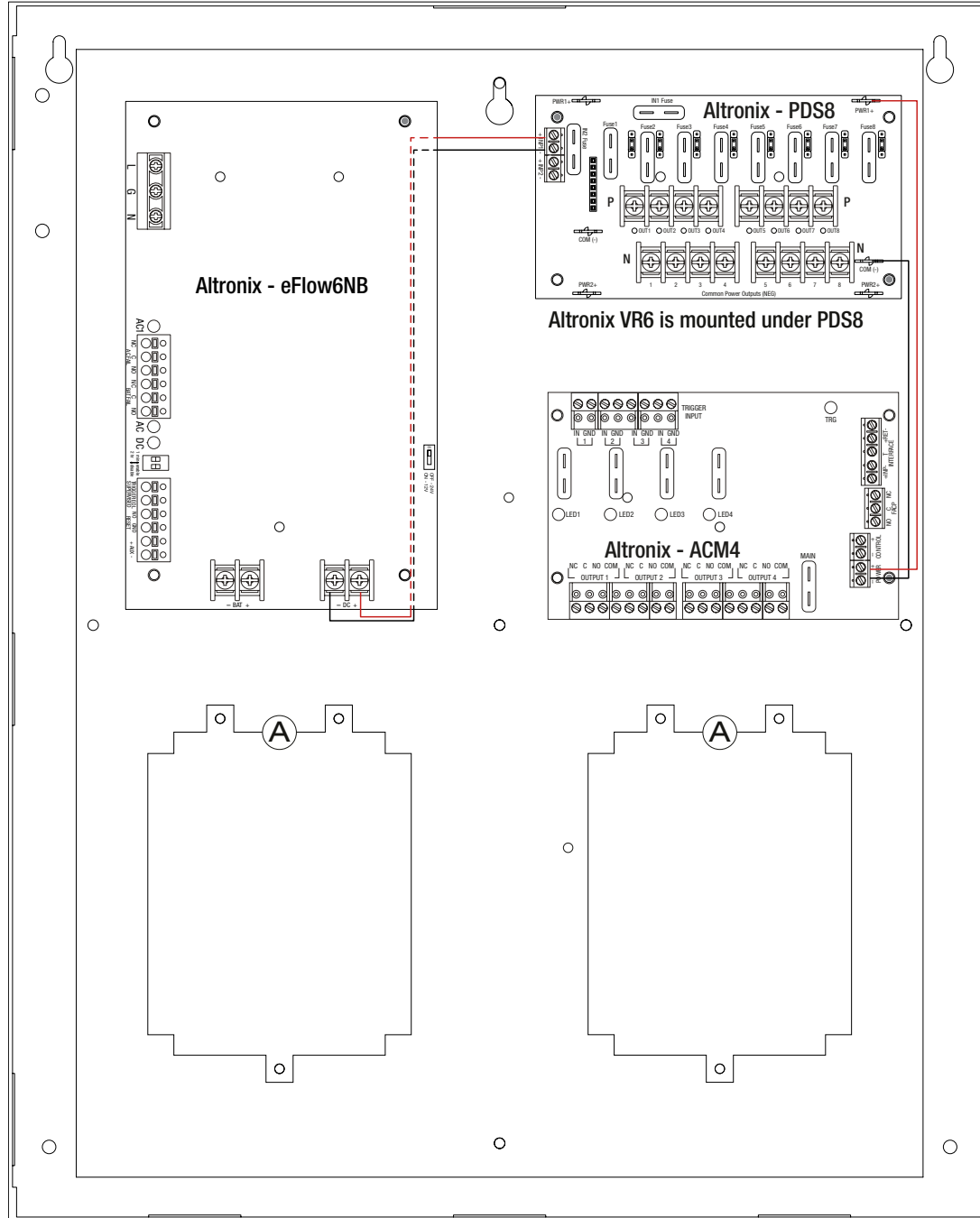

T2SAK7F8: Configuration of Salto Modules:

1. Fasten spacers onto metal pems configuration (A) of backplane (Fig. 3, pg. 4).
2. Position Salto modules over corresponding spacers and mount them utilizing pan head screws (provided) (Fig. 3a, pg. 4).
3. Mount backplane to enclosure with hardware.

Access Controller Position Chart for the Following Models:

Salto Access Controller	Pem Mounting
CU42E0, CU4200 or CU4EB8	(A)

Fig. 3

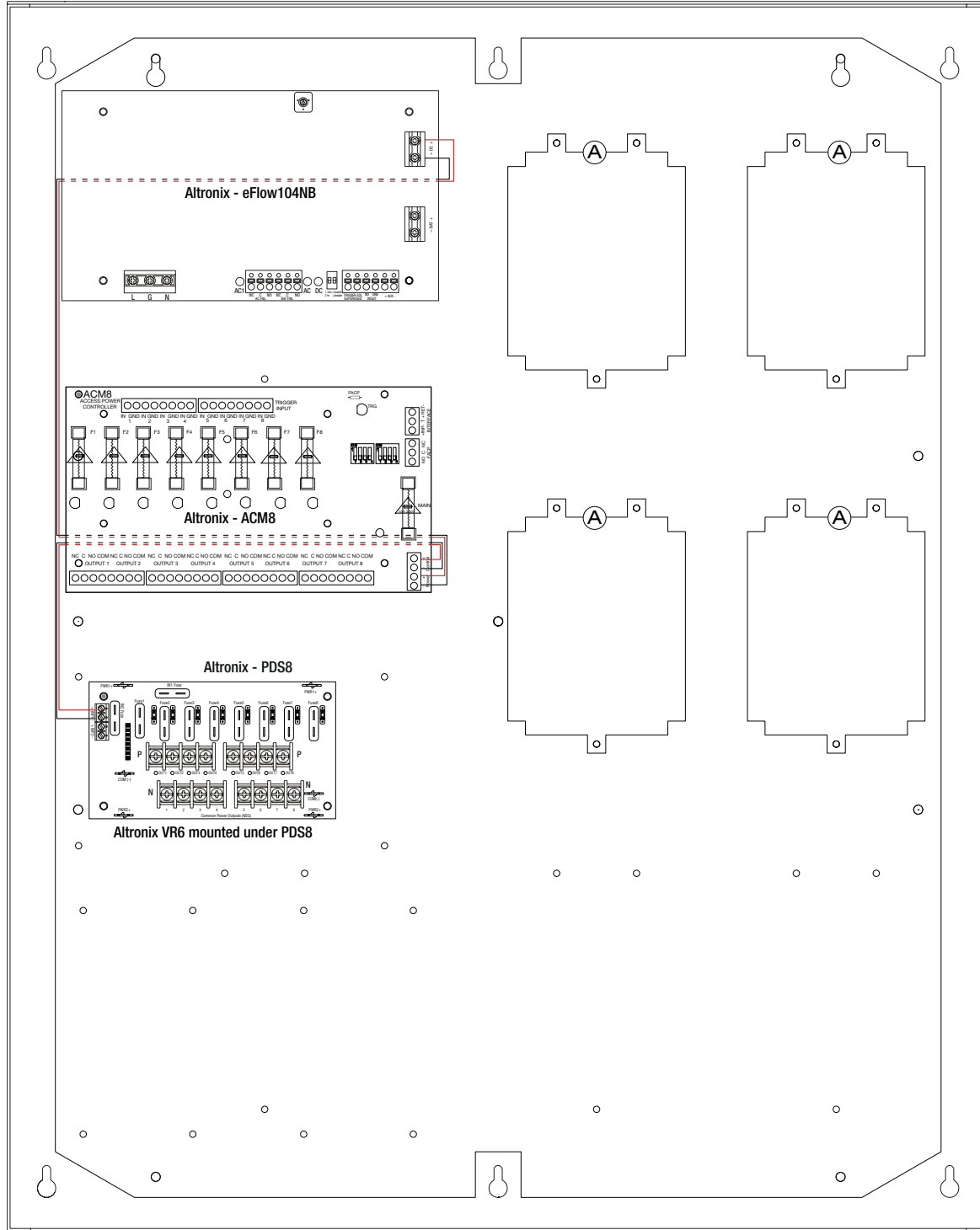
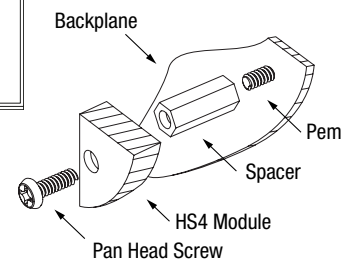

Fig. 3a



Trove SALTO (Fuse) Kits

T2SAK75F12: Configuration of Salto Modules:

1. Fasten spacers onto metal pems configuration (A) of backplane (Fig. 4, pg. 5).
2. Position Salto modules over corresponding spacers and mount them utilizing pan head screws (provided) (Fig. 4a, pg. 5).
3. Mount backplane to enclosure with hardware.

Access Controller Position Chart for the Following Models:

Salto Access Controller	Pem Mounting
CU42E0, CU4200 or CU4EB8	(A)

Fig. 4

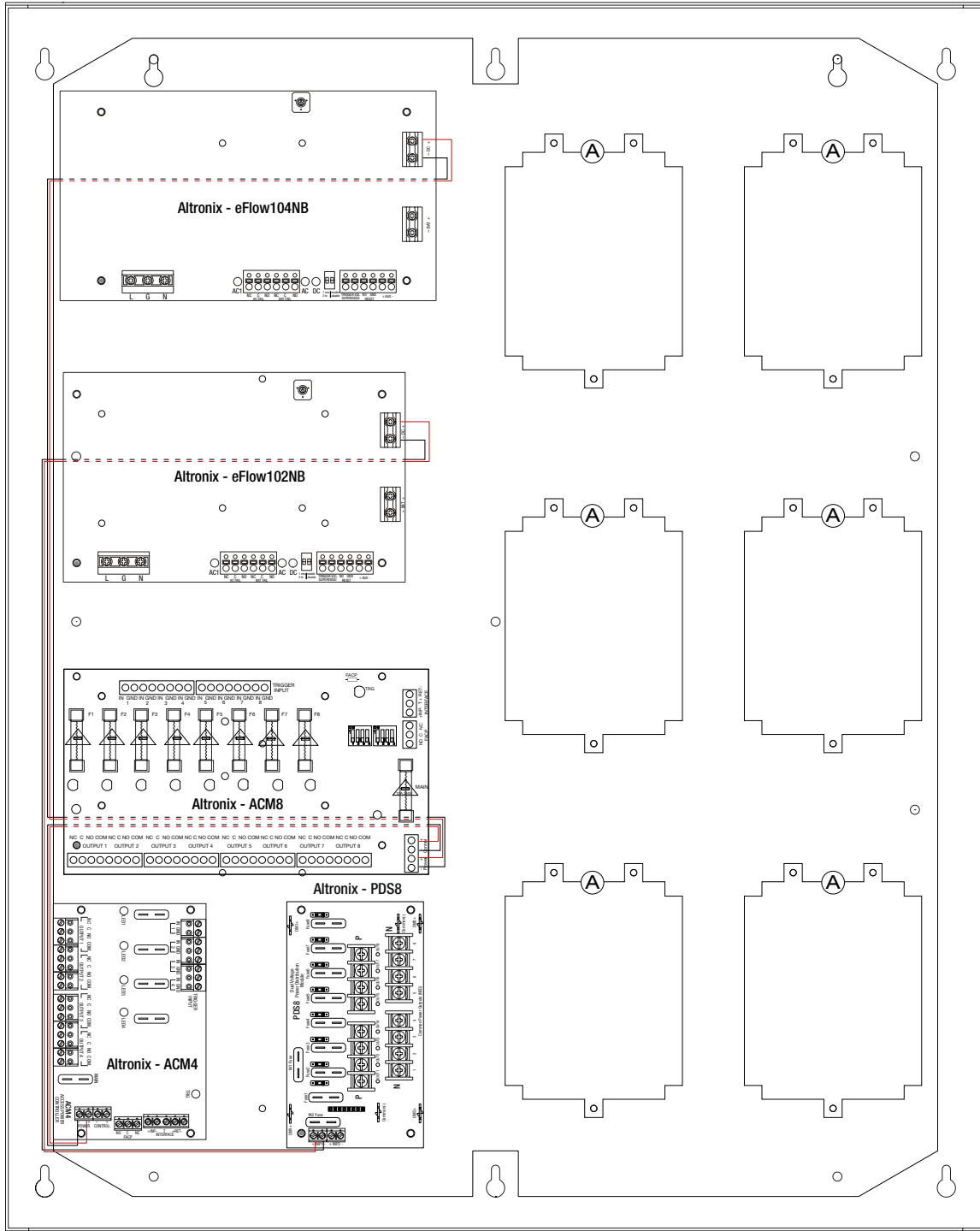
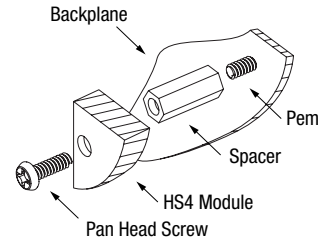
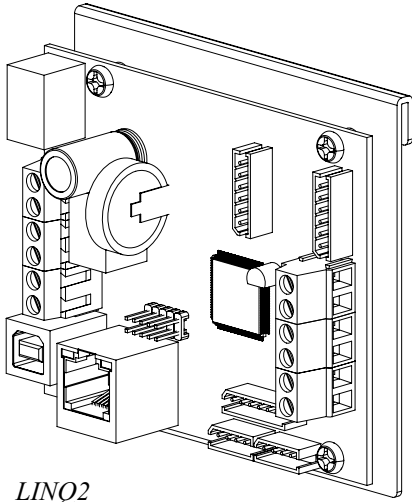

Fig. 4a





eFlow Power Supply/Chargers can be Controlled and Monitored while Reporting Power/Diagnostics from Anywhere over the Network...



LINQ2

LINQ™

LINQ2 - Network Communication Module

LINQ2 provides remote IP access to real-time data from eFlow power supply/chargers to help keep systems up and running at optimal levels. It facilitates fast and easy installation and set-up, minimizes system downtime, and eliminates unnecessary service calls, which helps reduce Total Cost of Ownership (TCO) - as well as creating a new source of Recurring Monthly Revenue (RMR).

Features:

- UL Listed in the U.S. and Canada.
- Local or remote control of up to (2) two Altronix eFlow power output(s) via LAN and/or WAN.
- Monitor real time diagnostics: DC output voltage, output current, AC & battery status/service, input trigger state change, output state change and unit temperature.
- Access control and user management: Restrict read/write, Restrict users to specific resources
- Two (2) integral network controlled Form "C" Relays.
- Three (3) programmable input triggers: Control relays and power supplies via external hardware sources.
- Email and Windows Dashboard notifications
- Event log tracks history.
- Secure Socket Layer (SSL).
- Programmable via USB or web browser - includes operating software and 6 ft. USB cable.

LINQ2 Mounts Inside any Trove Enclosure

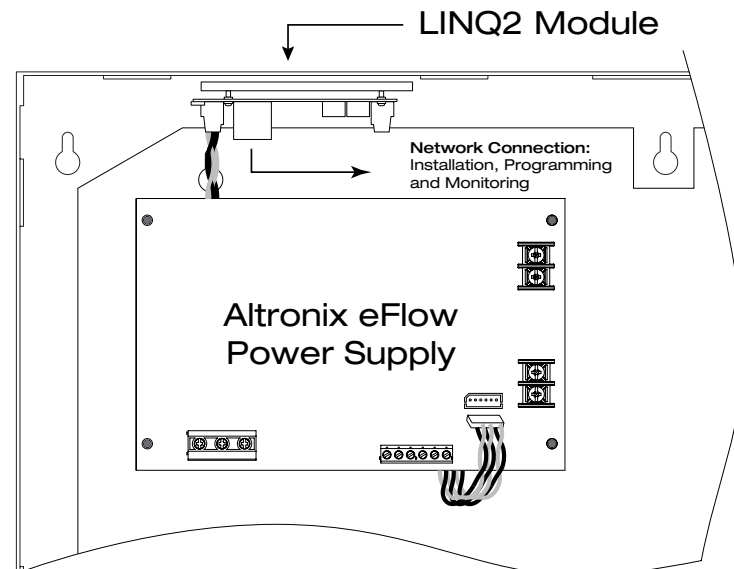

T1SAK3F4 Enclosure Dimensions (H x W x D):

18" x 14.5" x 4.625" (457mm x 368mm x 118mm)

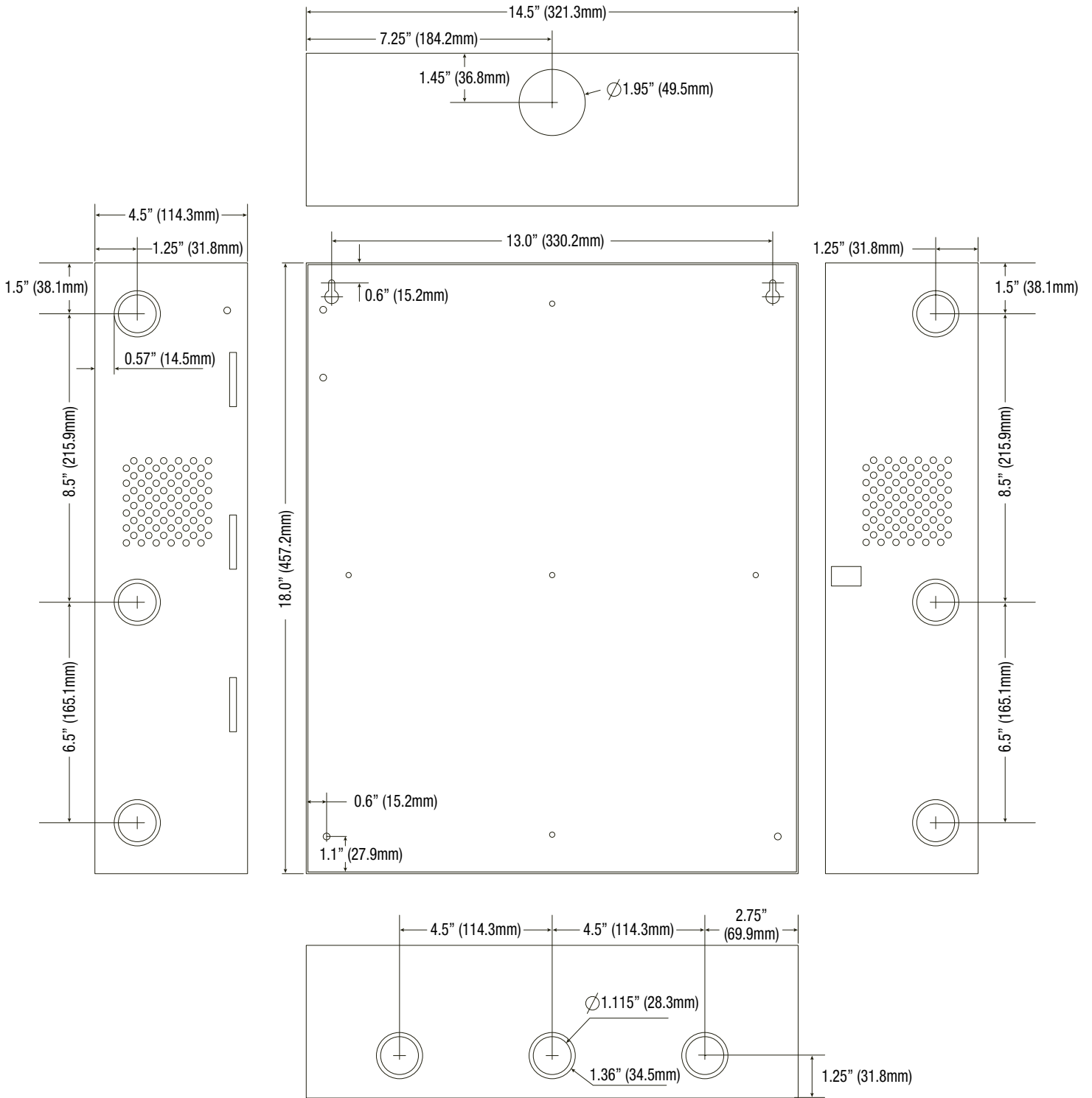

T2SAK7F8 and T2SAK75F12 Enclosure Dimensions (H x W x D):

27.25" x 21.75" x 6.5" (692.15mm x 552.5mm x 165.1mm)

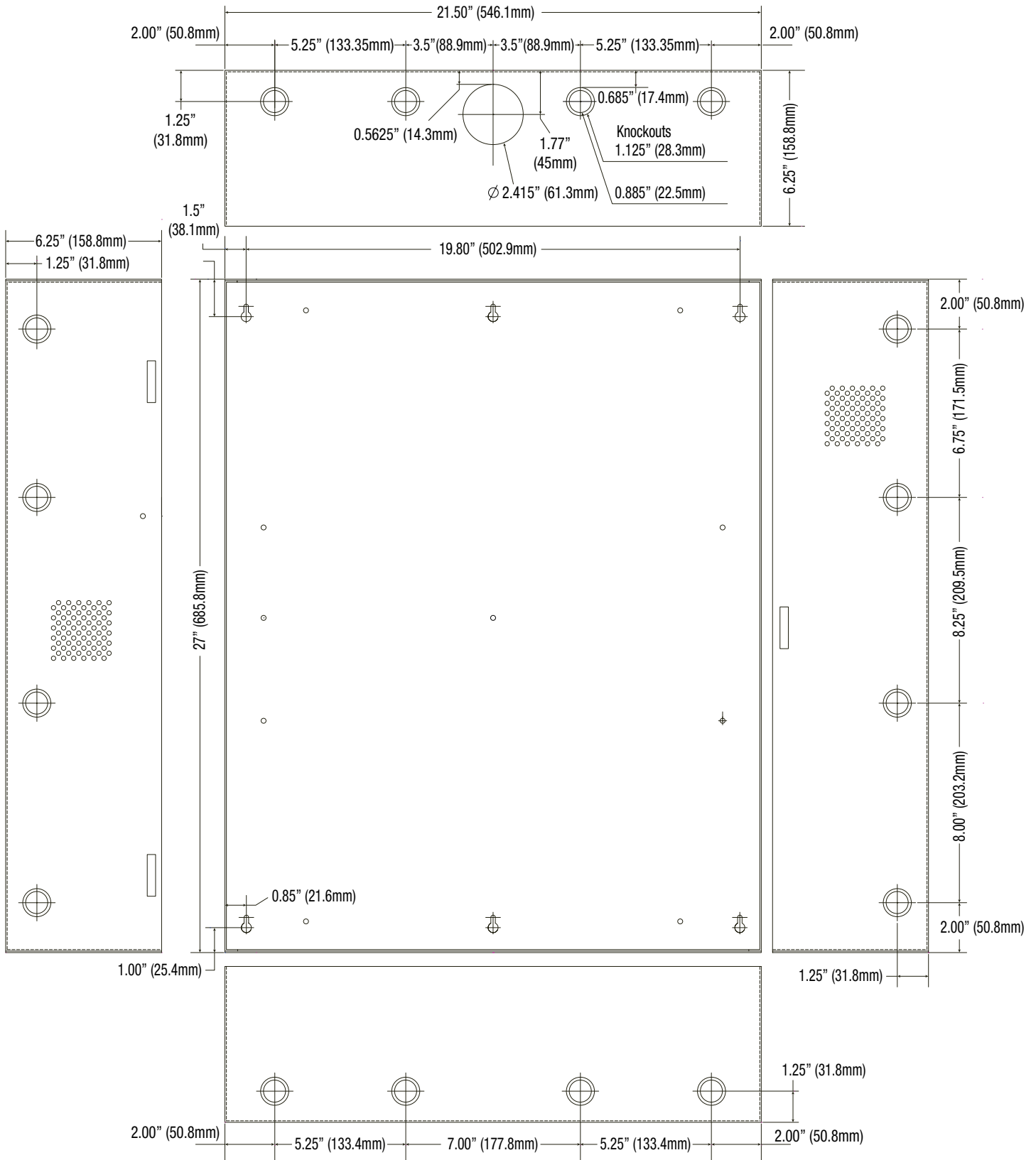

Altronix is not responsible for any typographical errors.

140 58th Street, Brooklyn, New York 11220 USA | phone: 718-567-8181 | fax: 718-567-9056

web site: www.altronix.com | e-mail: info@altronix.com | Made in U.S.A.

IITrove / SALTO

123T



Trove SALTO (Fuse) Kits