



# TROVE™

## *Access & Power Integration*

### ***T2HNK7F8***

#### ***8 Door Kit with Fused Outputs***

*Fully assembled kit includes:*

- Trove2 enclosure with THN2 Altronix/Honeywell NetAXS backplane
- One (1) eFlow104NB - Power Supply/Charger
- One (1) ACM8 - Fused Access Power Controller
- One (1) VR6 - Voltage Regulator
- One (1) PDS8 - Dual Input Fused Power Distribution Module

All components of this Trove kit are UL Listed sub-assemblies.

Please refer to the included corresponding Sub-Assembly Installation Guides for further information.

## ***Installation Guide***



**More than just power.™**

All registered trademarks are property of their respective owners.

Rev. 040819

Installing Company: \_\_\_\_\_ Service Rep. Name: \_\_\_\_\_

Address: \_\_\_\_\_ Phone #: \_\_\_\_\_

## Overview:

Altronix T2HNK7F8 Trove Honeywell NetAXS kit is pre-assembled and consists of Trove2HN2 enclosure/backplane with factory installed Altronix power supply/charger and sub-assemblies. T2HNK7F8 kit also accommodates various combinations of Honeywell NetAXS boards for up to eight (8) doors in a single enclosure.

### THN2 accommodates a combination of the following Honeywell NetAXS boards:

- Up to two (2) NX4PCB access control panels.
- Up to four (4) NetAXS-123 access control panels.
- Up to four (4) NXD1 or NXD2 add-on boards to NetAXS-123.
- Up to four (4) NX4IN or NX4OUT boards.

### Configuration Chart:

Altronix Model Number	Power Supply Board Input Fuse Rating	Power Supply Board Battery Fuse Rating	120VAC 60Hz Input Current (A)	Maximum Supply Current for Main and Aux. Outputs on Power Supply board and ACM8 Access Power Controllers' outputs	Nominal DC Output Voltage		Fail-Safe/Fail-Secure or Dry Form "C" Outputs	Additional Fused Outputs	ACM8 Board Input Fuse Rating	ACM8 Board Output Fuse Rating	PDS8 Board Input Fuse Rating	PDS8 Board Output Fuse Rating
					[DC]	[Aux]						
					Output Range (VDC)	Output Range (VDC)						
T2HNK7F8	6.3A/250V	15A/32V	4.5	24VDC @ 9.7A	20.17-26.4	20.28-26.4	8	8	10A/250V	2.5A/250V	10A/32V	3A/32V



### Installation Instructions:

Wiring methods shall be in accordance with the National Electrical Code/NFPA 70/ANSI, and with all local codes and authorities having jurisdiction. Product is intended for indoor use only.

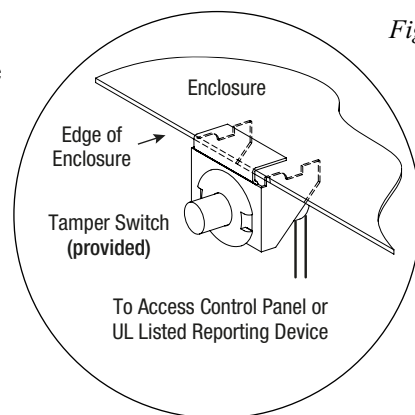
1. Remove backplane from enclosure. Do not discard hardware.
2. Mark and predrill holes in the wall to line up with the top three keyholes in the enclosure. Install three upper fasteners and screws in the wall with the screw heads protruding. Place the enclosure's upper keyholes over the three upper screws, level and secure. Mark the position of the lower three holes. Remove the enclosure. Drill the lower holes and install the three fasteners. Place the enclosure's upper keyholes over the three upper screws. Install the three lower screws and make sure to tighten all screws.
3. Mount included UL Listed tamper switch (Altronix Model TS112 or equivalent) in desired location, opposite hinge. Slide the tamper switch bracket onto the edge of the enclosure, approximately 2" from the right side (Fig. 1, pg. 2). Connect tamper switch wiring to the Access Control Panel input or the appropriate UL Listed reporting device. To activate alarm signal open the door of the enclosure.
4. Mount Honeywell NetAXS boards to THN2 backplane, refer to pages 3-5.
5. Refer to the *eFlow Power Supply/Charger Installation Guide* for eFlow104NB and corresponding *Sub-Assembly Installation Guides* for the following models: ACM8, PDS8 and VR6 for further installation instructions.



### Hardware:

 Nylon Spacer |  5/16" Pan Head Screw |  Lock Nut

## Configuration of Honeywell NX4PCB Boards:

1. Align Honeywell NX4PCB boards on the backplane to match the boards' mounting holes with corresponding pems.
2. Fasten spacers (provided) onto metal pems (*Fig. 2a, pg. 3*).
3. Mount Honeywell NX4PCB boards to spacers utilizing pan head screws (provided) (*Fig. 2a, pg. 3*).  
**Note:** Honeywell NX4PCB boards have one (1) RJ45 jack and one (1) switch each.  
 Please make sure that they are mounted correctly, as shown in *Fig. 2* below.
4. Fasten THN2 backplane to Trove2 enclosure utilizing hardware (provided).

Fig. 2

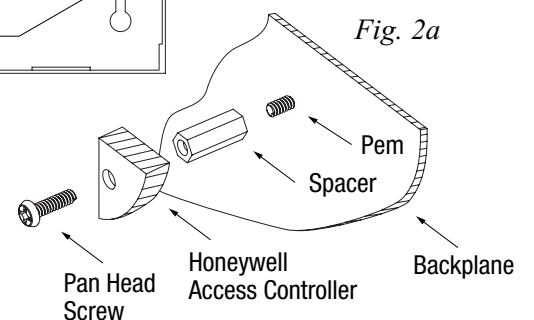
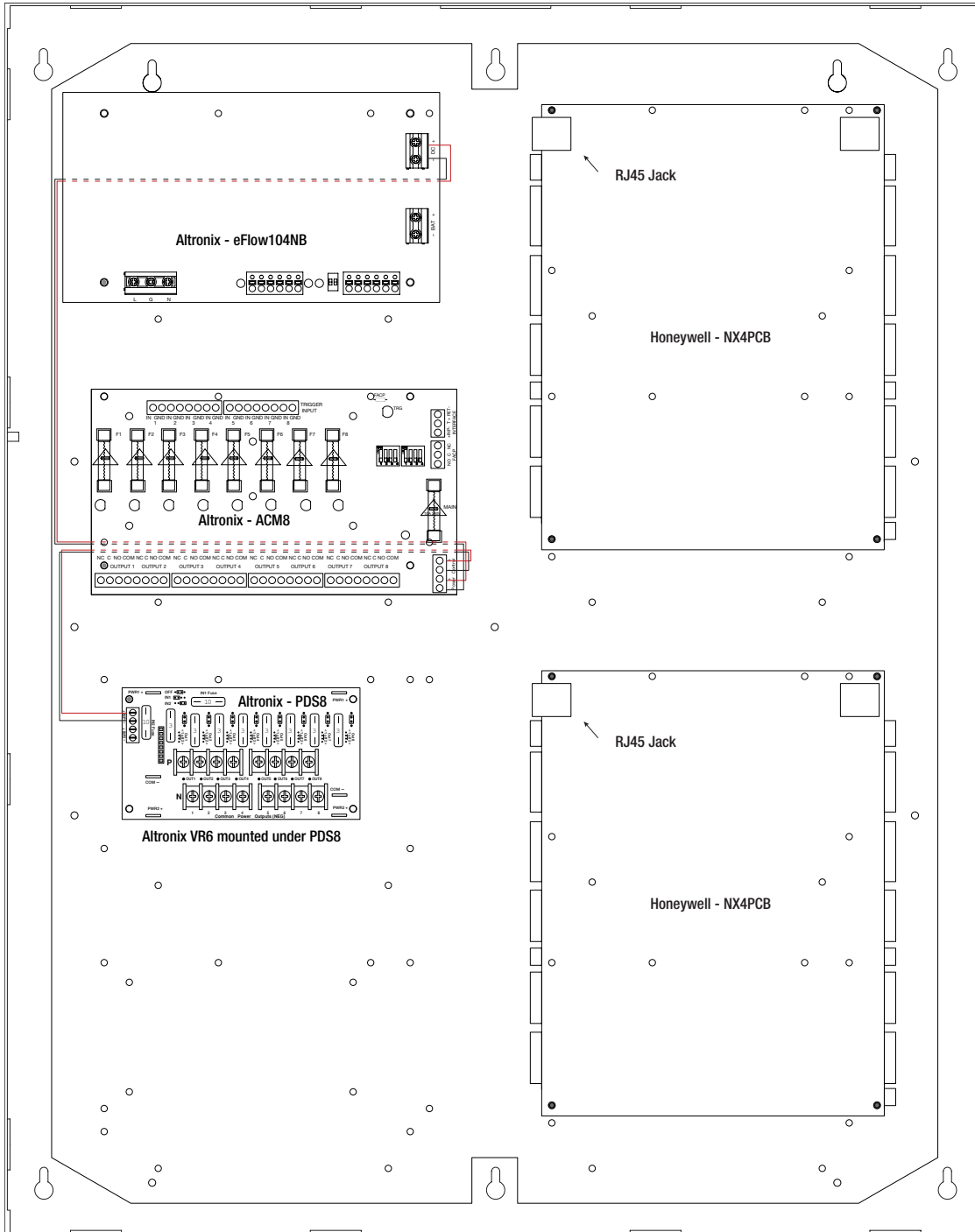

## Configuration of Honeywell NetAXS-123 with or without NXD1/NXD2 Boards:

1. Align Honeywell NetAXS-123 boards on the backplane to match the boards' mounting holes with corresponding pems.
2. Fasten spacers (provided) onto metal pems (*Fig. 3a, pg. 4*).
3. Mount Honeywell NetAXS-123 boards to spacers utilizing pan head screws (provided) (*Fig. 3a, pg. 4*).

**Note:** Honeywell NetAXS-123 boards have one (1) RJ45 jack.

Please make sure that they are mounted correctly, as shown in *Fig. 3* below.

In order to properly mount and connect NXD1/NXD2 do the following:

- prior to mounting on backplane, attach NXD1/NXD2 to the NetAXS-123 by connecting the multi-pin connector on the bottom of NXD1/NXD2 to the multi-pin jack on NetAXS-123. Make sure that pre-installed bump screws on NXD1/NXD2 go through the corresponding holes in NetAXS-123.
  - secure NXD1/NXD2 to NetAXS-123 using pre-installed bump screws and included spacers (*Fig. 3b, pg. 4*).
  - after NXD1/NXD2 is firmly attached and connected to NetAXS-123, follow steps 1 and 2 above to mount them onto THN2.
4. Fasten THN2 backplane to Trove2 enclosure utilizing hardware (provided).

*Fig. 3*

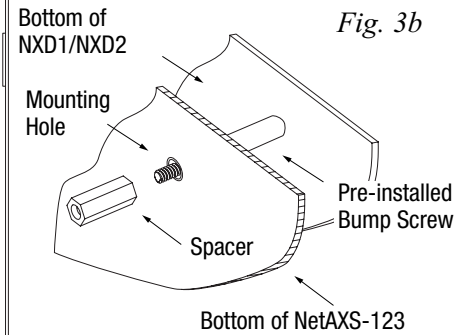
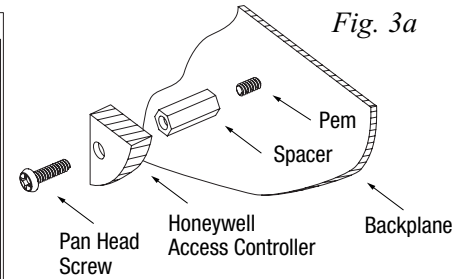
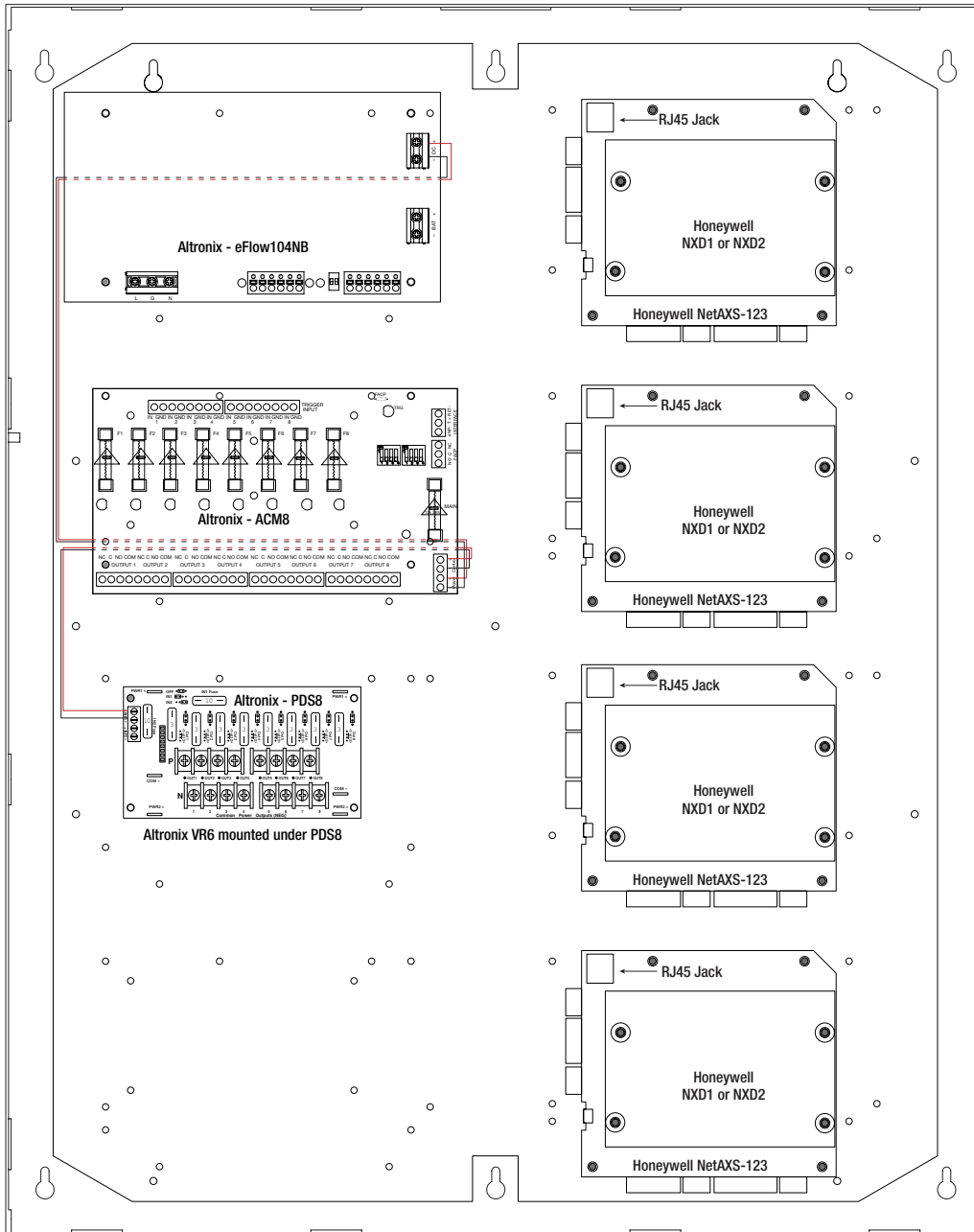

## Configuration of Honeywell NX4IN or NX4OUT Boards:

1. Align Honeywell NX4IN or NX4OUT boards on the backplane to match the boards' mounting holes with corresponding pems.
2. Fasten spacers (provided) onto metal pems (*Fig. 4a, pg. 5*).
3. Mount Honeywell NX4IN or NX4OUT boards to spacers utilizing pan head screws (provided) (*Fig. 4a, pg. 5*).
4. Fasten THN2 backplane to Trove2 enclosure utilizing hardware (provided).

Fig. 4

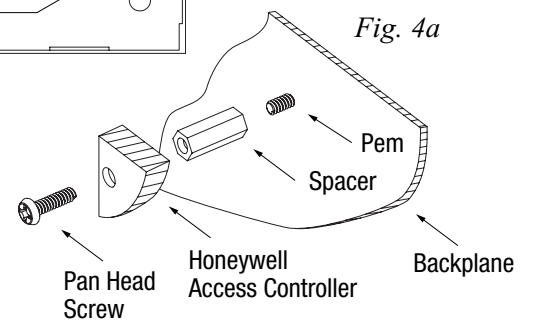
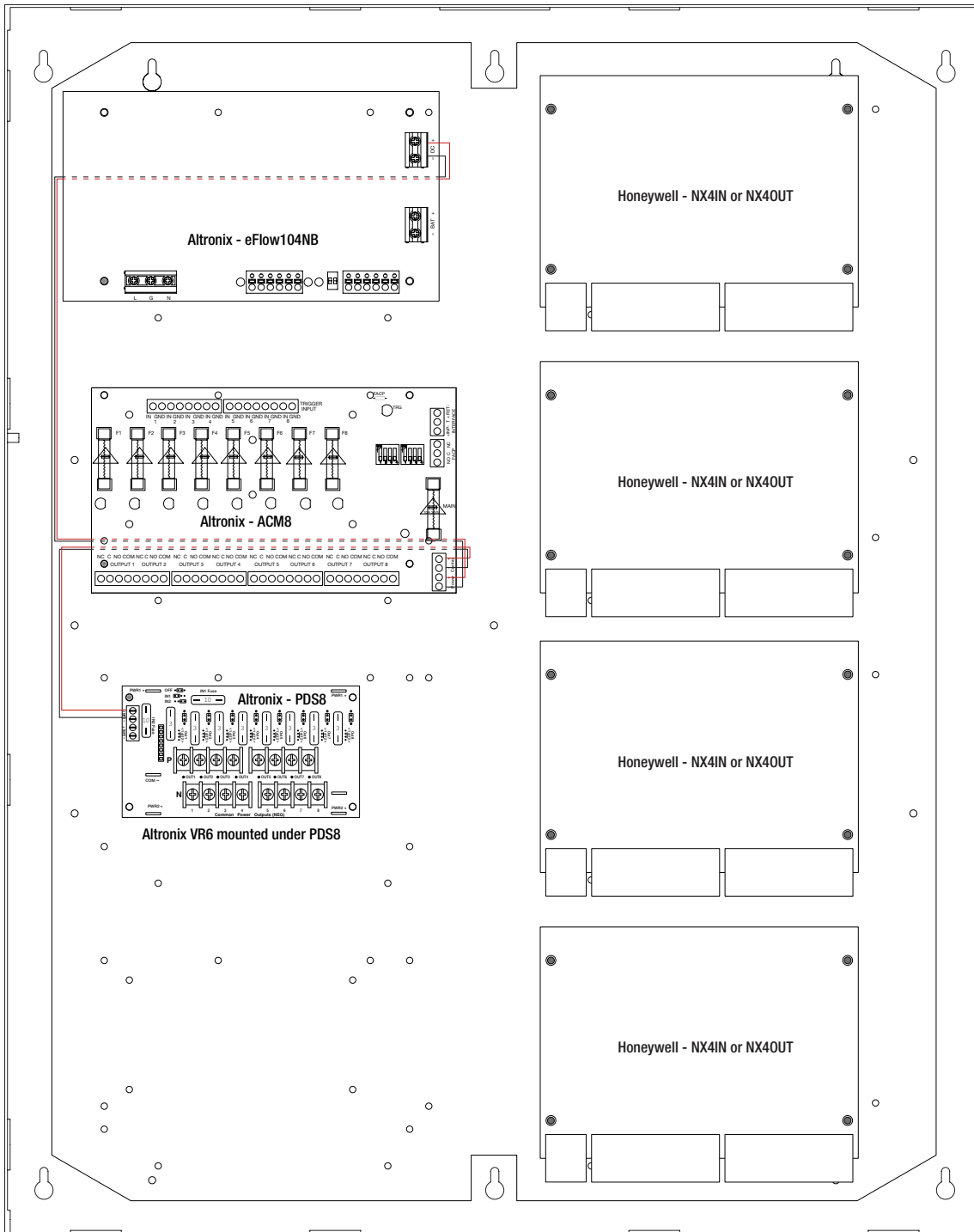

**Notes:**



**eFlow Power Supply/Chargers can be Controlled and Monitored while Reporting Power/Diagnostics from Anywhere over the Network...**

# LINQ™

## **LINQ2 - Network Communication Module**

LINQ2 provides remote IP access to real-time data from eFlow power supply/chargers to help keep systems up and running at optimal levels. It facilitates fast and easy installation and set-up, minimizes system downtime, and eliminates unnecessary service calls, which helps reduce Total Cost of Ownership (TCO) - as well as creating a new source of Recurring Monthly Revenue (RMR).

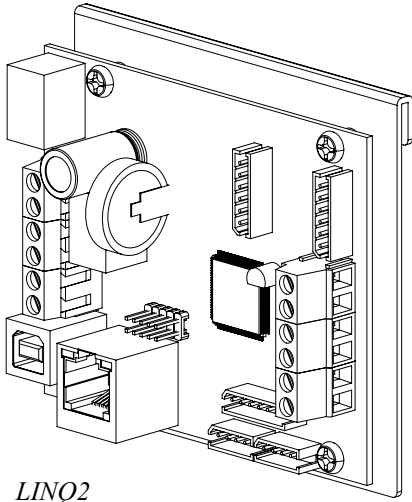

LINQ2

### **Features:**

- UL Listed in the U.S. and Canada.
- Local or remote control of up to (2) two Altronix eFlow power output(s) via LAN and/or WAN.
- Monitor real time diagnostics: DC output voltage, output current, AC & battery status/service, input trigger state change, output state change and unit temperature.
- Access control and user management: Restrict read/write, Restrict users to specific resources
- Two (2) integral network controlled Form "C" Relays.
- Three (3) programmable input triggers: Control relays and power supplies via external hardware sources.
- Email and Windows Dashboard notifications
- Event log tracks history.
- Secure Socket Layer (SSL).
- Programmable via USB or web browser - includes operating software and 6 ft. USB cable.

### **LINQ2 Mounts Inside any Trove Enclosure**

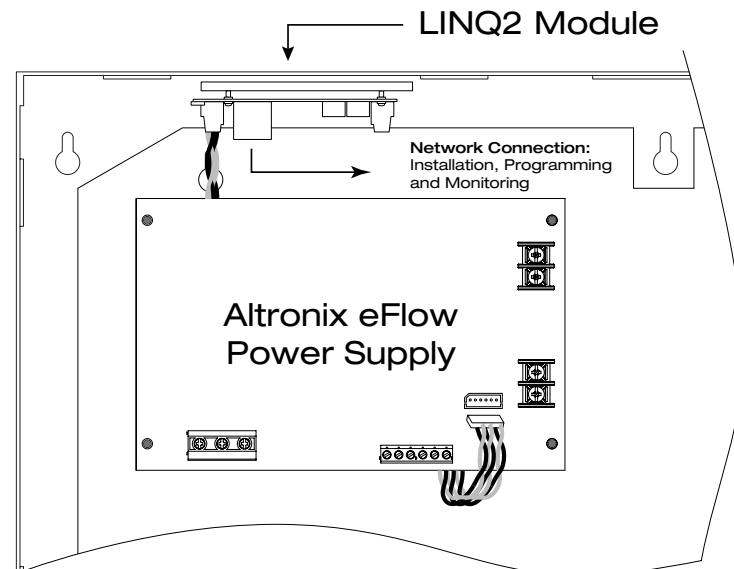

**Enclosure Dimensions (H x W x D approximate):**  
 27.25" x 21.75" x 6.5" (692.2mm x 552.5mm x 165.1mm)

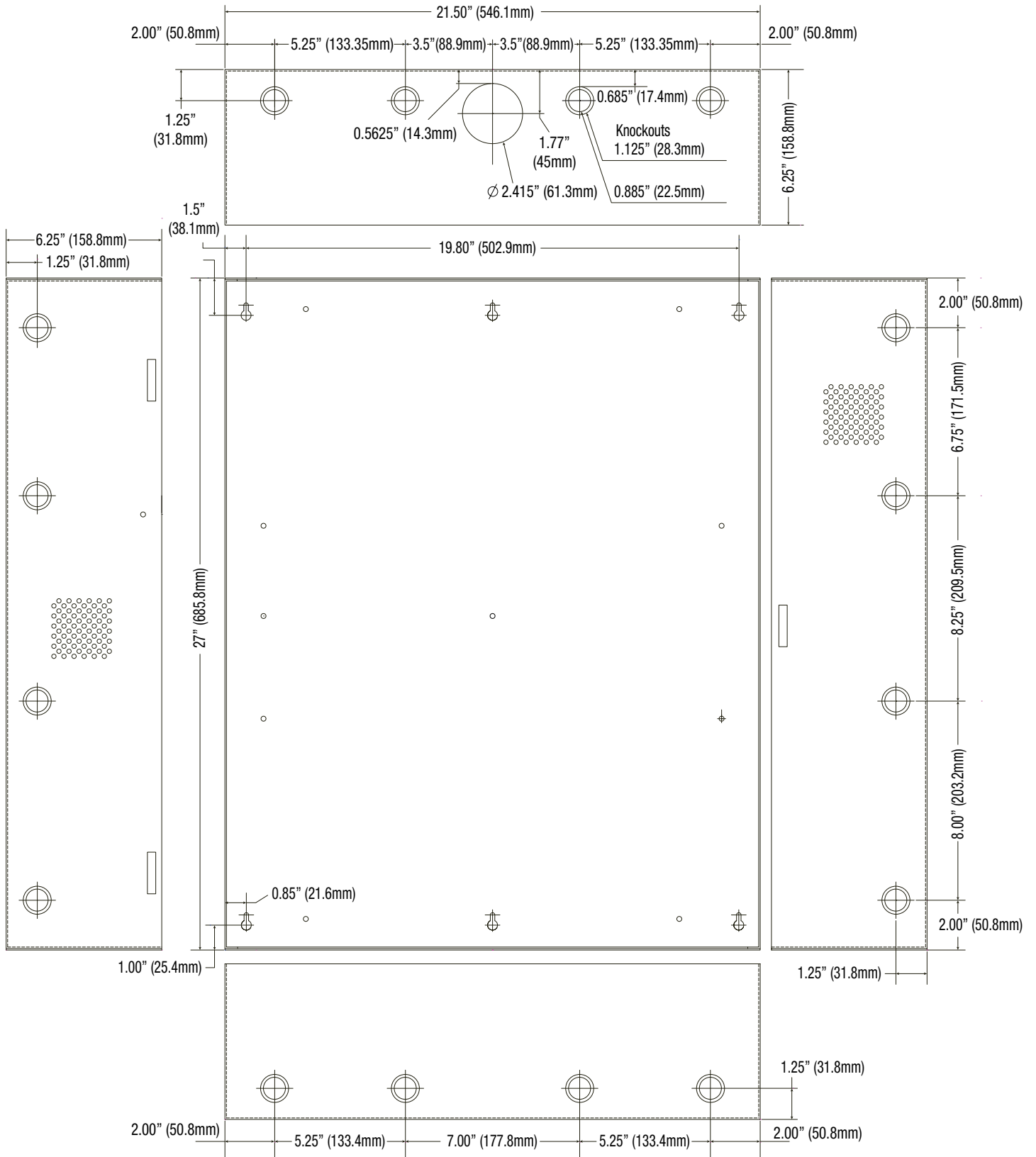

Altronix is not responsible for any typographical errors.

140 58th Street, Brooklyn, New York 11220 USA | phone: 718-567-8181 | fax: 718-567-9056  
 web site: [www.altronix.com](http://www.altronix.com) | e-mail: [info@altronix.com](mailto:info@altronix.com) | Lifetime Warranty | Made in U.S.A.  
 IIT2HMK7F8

J05T

