

PACE

Long Distance Ethernet Solution

PacePRM Series

Long Range Ethernet Receivers

Models Include:

Pace4PRM

- Four (4) Channel Receiver

Pace8PRM

- Eight (8) Channel Receiver

Pace16PRM

- Sixteen (16) Channel Receiver

Installation Guide



LISTED

I.T.E. 43KC

Rev. 072914



More than just power.™

Installing Company: _____ Service Rep. Name: _____

Address: _____ Phone #: _____

Overview:

Pace4/8/16PRM are long range Ethernet receivers that transmit data at 100Mbps full duplex and power via CAT5e or higher cable in a PoE(+) compliant format. Pace4/8/16PRM receivers are powered via a PoE midspan, such as the Altronix Netway series, or by an endspan. The receiver passes the PoE(+) compliant power over the cable to the Pace1PTM transceiver which in turn passes this power to an enabled IP camera/device. These plug and play units facilitate cost effective solutions for IP devices that need to be installed at the distances greater than 100m. They also provide a simple way to replace legacy analog products with new IP devices over structured cable.

Features:

Agency Listings:

- **UL 60950-1** Information Technology Equipment.
- **CE** European Conformity.
- **C-Tick** C-Tick compliant.

Input (Pace4/8/16PRM):

- Powered by midspan or endspan.
PoE compliant to IEEE 802.3af (15W) and PoE+ compliant to IEEE 802.3at (30W).

Ethernet:

- Connectivity: RJ45, auto-crossover.
- Wire type: 4-pair CAT5e.
- Distance: up to 500m.
- Speed: 100BaseT, full duplex, auto negotiation.
PoE compliant to IEEE 802.3af (15W) and PoE+ compliant to IEEE 802.3at (30W) delivered to camera by Pace1PTM/Pace1ST.
Power provided by Pace4/8/16PRM to Pace1PTM/Pace1ST by PoE protocol.

CAT5e or Higher:

- Throughput is rated to pass 100Mbps of data at distances up to 500m. With proper headend equipment this supports Megapixel, HD720, HD1080.
- Distance: up to 500m @ 100Mbps (see *Maximum Length of CAT5e Type vs. Camera Power/PoE Class, pg. 4*).

LED Indicators:

- Refer to *Technical Specifications chart, page 5*.

Environmental:

- **Operating and Storage Temperature:**
Refer to *Technical Specifications chart, page 5*.
- Humidity: 20 to 85%, non-condensing.

Applications:

- Works with Megapixel, HD720, HD1080 and VGA (SD) cameras (see *note, pg. 2*).
- Extend Network link distance in an industrial environment (see *note, pg. 2*).

Mechanical:

- Dimensions (H x W x D approx.):

Pace4PRM:

1.7" x 5.25" x 8.42"
(43.8mm x 133.4mm x 213.9mm)

Pace8PRM/16PRM:

1.625" x 19.125" x 8.5"
(42mm x 486mm x 216mm)

Pace1PTM:

1" x 2.5" x 4.375"
(25.4mm x 63.5mm x 111.1mm)

Pace1ST:

2.27" x 2.645" x 1.12"
(57.7mm x 67.2mm x 28.4mm)

Installation Instructions:

Wiring methods shall be in accordance with the National Electrical Code/NFPA 70/ANSI, and with all local codes and authorities having jurisdiction. Wiring should be UL Listed and/or Recognized wire suitable for the application. Pace4/8/16PRM is not intended to be connected to outside plant leads and should be installed indoors within the protected premises. The Pace4/8/16PRM and Pace1PTM are intended for indoor use only.

Elevated Operating Ambient - If installed in a closed or multi-unit rack assembly, the operating ambient temperature of the rack environment may be greater than room ambient. Therefore, consideration should be given to installing the equipment in an environment compatible with the maximum ambient temperature (T_{ma}) specified by the manufacturer.

Reduced Air Flow - Installation of the equipment in a rack should be such that the amount of air flow required for safe operation of the equipment is not compromised. Do not obstruct any air vents on the unit. It is recommended to leave half space above and below the unit.

Mechanical Loading - Mounting of the equipment in the rack should be such that a hazardous condition is not achieved due to uneven mechanical loading.

Note: *Caution: once PoE connection is established between Pace4/8/16PRM and Pace1PTM, disconnecting the CAT5 from Pace1PTM will not disable the PoE compliant voltage from the Pace4/8/16PRM. Although the Pace1PTM can be reconnected, caution should be taken not to connect the CAT5 wiring from Pace4/8/16PRM to any non-PoE device.*

1. **Pace4/8/16PRM** installation:
 - a. Pace4PRM - Affix rubber pads to Pace4PRM for shelf installation (*Fig. 5, pg. 6*).
 Pace8/16PRM - Attach mounting brackets to Pace8/16PRM unit for rack installation (*Fig. 4, pg. 6*).
 Affix rubber pads to Pace8/16PRM for shelf installation (*Fig. 5, pg. 6*).
 Unit should be located in proximity to ethernet switch/network, NVR or video server.
 - b. Connect structured cables from port marked [IN] on Pace4/8/16PRM to the corresponding inputs of an ethernet midspan or endspan device (*Fig. 3, pg. 4*).
 - c. Connect structured cables from port marked [OUT] on Pace4/8/16PRM to Pace1PTM (*Fig. 3, pg. 4*).
2. **Pace1PTM/Pace1ST** installation:
 - a. Secure unit to desired mounting surface with a proper fastening device utilizing the case's mounting hole.
 Unit should be mounted in proximity of camera/device.
 - b. Connect structured cable from IP camera/device to RJ45 jack marked [PoE Out] (*Fig. 2, pg. 3*).
 - c. Connect structured cables from Pace4/8/16PRM to RJ45 jack marked [RJ45 Link] (*Fig. 2, pg. 3*).

Note: The Pace4/8/16PRM is designed to accommodate Megapixel, HD720, HD1080, and VGA (SD) cameras. It is important to note that some high resolution and high frame rate cameras may demand faster headend processing ability, such as a PC graphics card, to present a quality image. If the headend processing equipment is insufficient in speed, the image may show pixelation and latency. It is advisable to pretest system if unsure. Alternatively, frame rate and resolution may be reduced to accommodate system equipment.

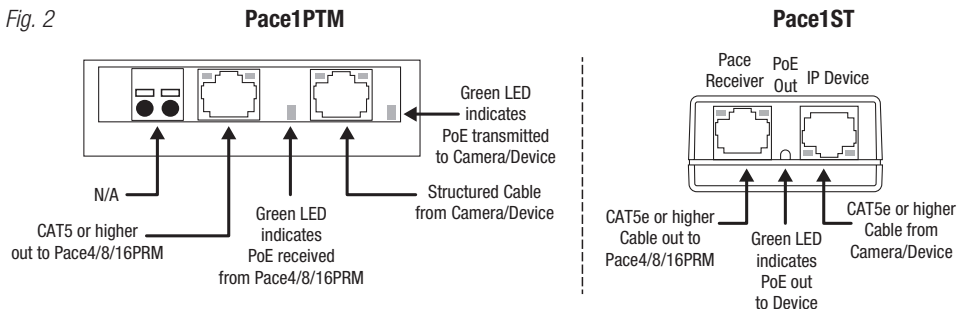
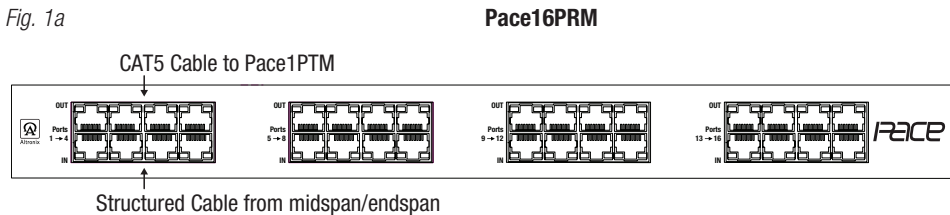
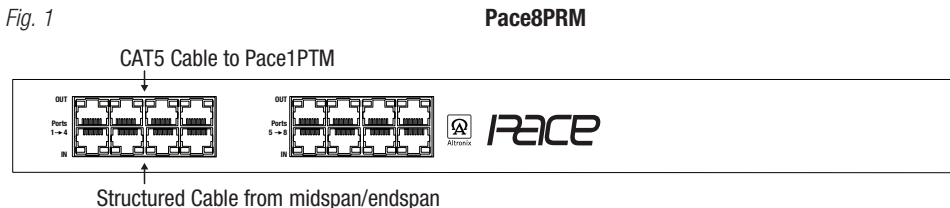

Multiple PoE Camera Connection:

Pace8PRM shown. Pace16PRM is similar, with twice as many channels.

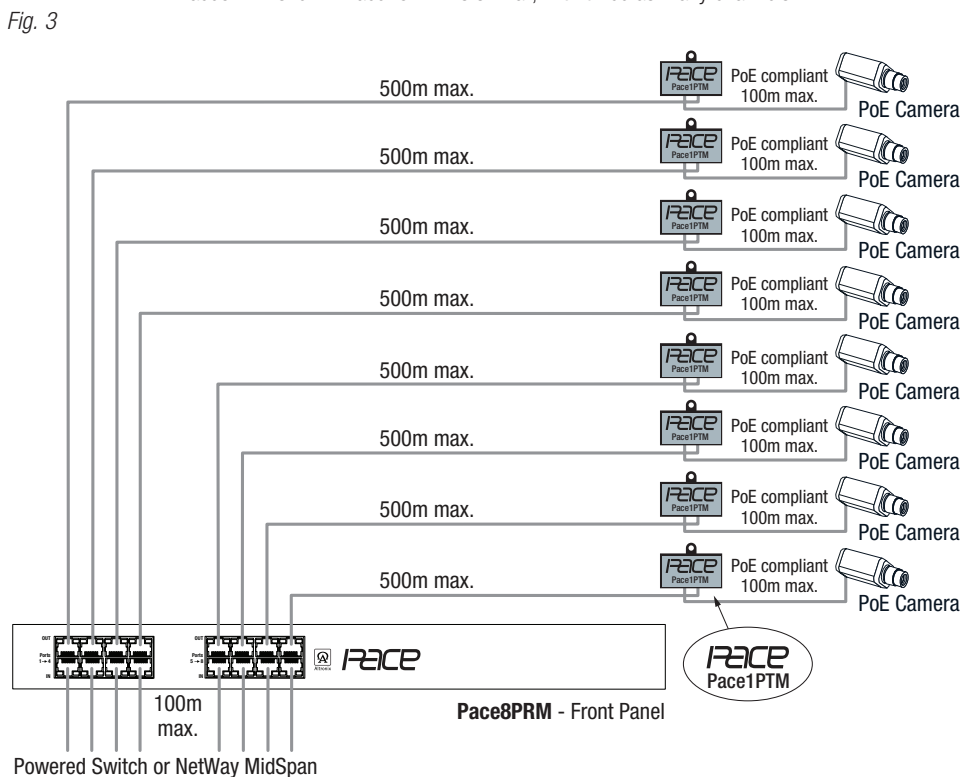

Maximum Length of CAT5e Type vs. Camera Power/PoE Class:

Camera Power/PoE Class	CAT5 or Higher
	Max. Length (meters)
13W/0	500m
4W/1	500m
6.5W/2	500m
13W/3	500m
25W/4	423m

Note: Higher gauge wiring will allow for longer distances.

Technical Specifications:

Parameter	Description
Connections	RJ45 for ethernet link.
Input Power Requirements	UL Listed power-limited midspan or endspan port connected.
Indicators	<p>Pace4/8/16PRM: Green and Yellow LED (RJ45) IP Link status, 100Base-T/active.</p> <p>Pace1PTM: Green PoE Active. Yellow (RJ45 Connector) On - Link, Off - No Link, Blinking - Activity Green (RJ45 Connector) On - 100Base-TX, Off 10Base-T</p> <p>Pace1ST: Green PoE Active. Yellow (RJ45 Connector) On - Link, Off - No Link, Blinking - Activity Green (RJ45 Connector) On - 100Base-TX, Off - 10Base-T</p>
Environmental Conditions	<p>Operating Ambient Temperature: UL60950-1 Pace4/8/16PRM: – 20°C to 49°C (– 4°F to 120.2°F).</p> <p>Pace1PTM: For 15W: – 40°C to 75°C (– 40°F to 167°F). For 25W: – 40°C to 70°C (– 40°F to 158°F). For 30W: – 40°C to 60°C (– 40°F to 140°F).</p> <p>Pace1ST: For 15W: – 40°C to 75°C (– 40°F to 167°F). For 30W: – 40°C to 49°C (– 40°F to 120°F).</p> <p>Storage Temperature: – 40°C to 75°C (– 40°F to 167°F). Relative humidity: 20 to 85%, non-condensing. Operating Altitude: – 304.8 to 2,000m.</p>
Regulatory Compliance	UL/cUL Listed for Information Technology Equipment (UL 60950-1). CE European Conformity. C-Tick compliant.
Weights (approx.)	<p>Pace4PRM: Product: 1.35 lbs. (0.61 kg); Shipping: 1.7 lbs. (0.77 kg)</p> <p>Pace8PRM: Product: 5.8 lbs. (2.63 kg); Shipping: 7.8 lbs. (3.54 kg)</p> <p>Pace16PRM: Product: 7.2 lbs. (3.27 kg); Shipping: 9.2 lbs. (4.17 kg)</p>

Mounting Options:

Rack Mount Installation (Pace8PRM and Pace16PRM)

- 1- Remove and discard factory installed screws from both sides of rack chassis (*Fig. 4a*).
- 2- Install mounting brackets (A) on the left and right side of rack chassis using the four (4) flat head screws (B) (included) (*Fig. 4b*).
- 3- Place unit into desired EIA 19" rack position and secure with mounting screws (*not included*) (*Fig. 4c*).

Fig. 4
Fig. 4a

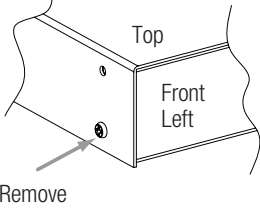

Fig. 4b

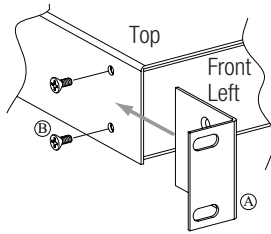
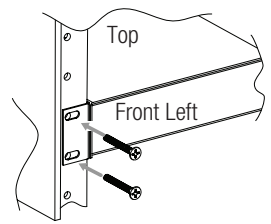

Fig. 4c



Shelf Installation

- 1- Position and affix rubber pads (C) (included) at each corner on the bottom of the unit (*Fig. 5*).
- 2- Place unit in desired location.

Fig. 5

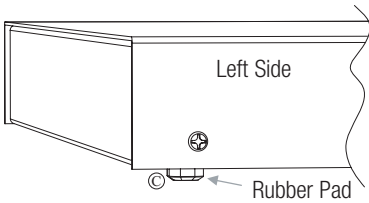

Mounting Hardware (Included):

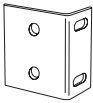

Ⓐ Two (2) mounting brackets (except Pace4PRM).



Ⓑ Six (6) flat head screws for mounting brackets (except Pace4PRM).



Ⓒ Four (4) rubber pads.

Enclosure Dimensions (H x W x D approximate):

1.7" x 5.25" x 8.42" (43.8mm x 133.35mm x 213.9mm)

Pace4PRM

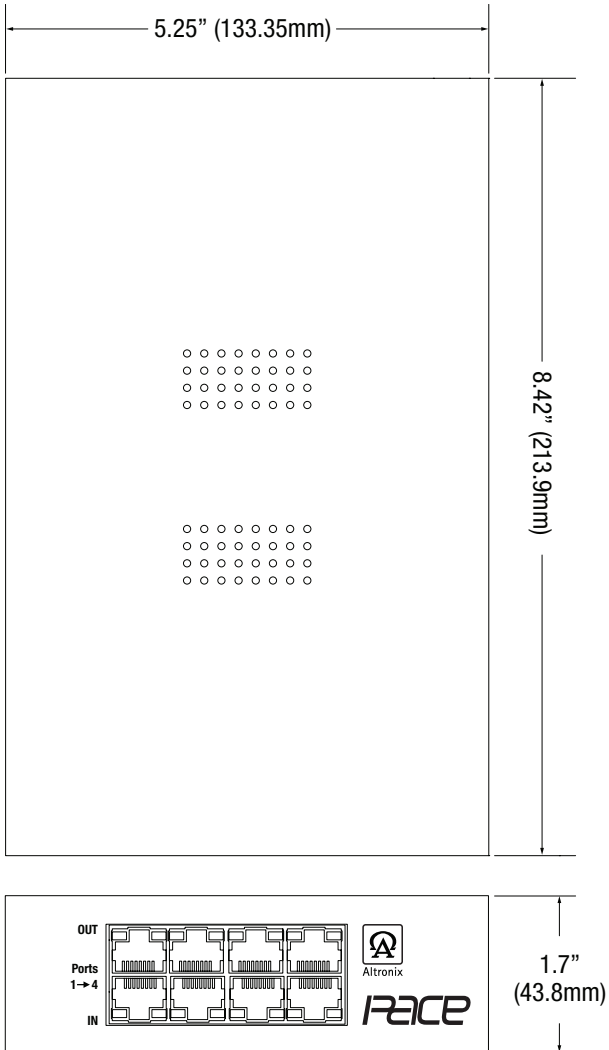

Enclosure Dimensions (H x W x D approximate):

1.625" x 19.125" x 8.5" (42mm x 486mm x 216mm)

Pace16PRM is shown. **Pace8PRM** is similar.

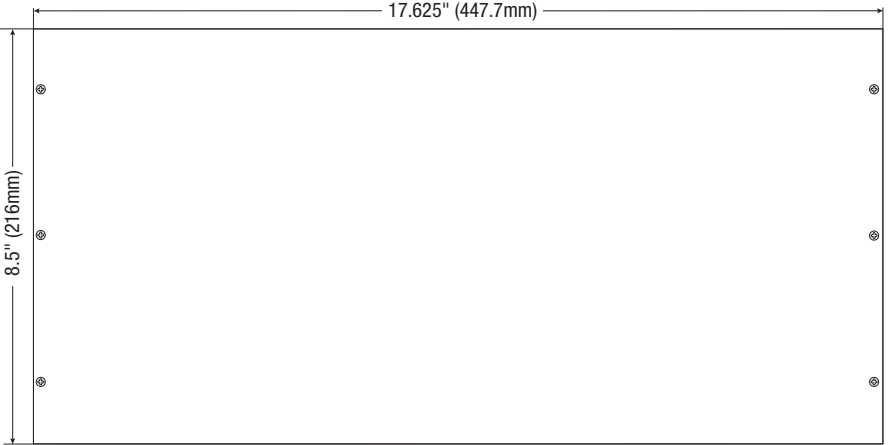
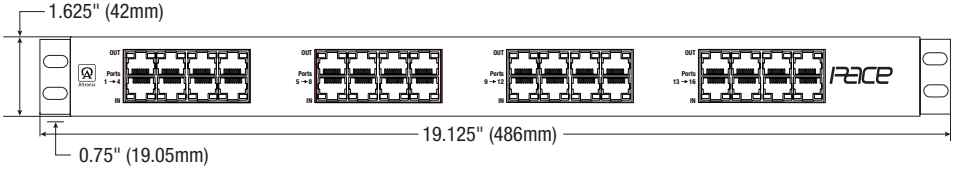

Altronix is not responsible for any typographical errors.

140 58th Street, Brooklyn, New York 11220 USA | phone: 718-567-8181 | fax: 718-567-9056
website: www.altronix.com | e-mail: info@altronix.com | Lifetime Warranty
IPace4/8/16PRM 109U

