

Overview:

Model DTMR1 programmable timer is suitable for many functions that require a timed operation e.g. Access Control Applications, Siren/Bell Cut Off Module, Dialer Delay, Guard Tour Supervisory Timer, etc. Some optional functions include: One Shot, Delayed Release, Delayed Operate, Delayed Pulse, and Pulsar/Flasher. A new feature has been added which provides a momentary relay activation at the end of a desired timing cycle. This feature eliminates the need for having to use two (2) timers to achieve this function. Another new feature will cancel (interrupt) timing cycle and reset timer if desired.

Specifications:

Input:

- 12VDC or 24VDC operation is selectable.

Visual Indicators:

- LED indicates relay is energized.

Electrical:

- Operating temperature: -20° C to 49° C ambient.
- Form "C" relay contacts are 8A at 120VAC/28VDC.
- Current Draw: Stand-by 3mA; Relay Energized 40mA.

Features:

- Quick and extremely accurate time range adjustment from 1 sec. to 60 min.

Features (cont.):

- Triggers via positive DC (+) voltage, dry contact closure, or removal of contact closure.
- Selectable relay activation at the start or end of the timing cycle.
- One (1) second momentary relay activation at the end of the timing cycle (eliminates the need to use two (2) timers for this function).
- Built-in reset feature which cancels timing cycle.
- Repeat (pulsar/flasher) mode.
- Includes Snap Track ST3 and clips.

Board Dimensions (L x W x H approx.):

3" x 2.5" x 0.75" (76.2 mm x 63.5 mm x 19.05 mm).

Installation Instructions:

1. Mount DTMR1 using included ST3 snap track and clips:
 - Slide the board into the outermost slots on the ST3 (*Fig. 1*);
 - Attach the clips to the back of ST3 using provided guides and slots;
 - Mount DTMR1 onto the DIN rail using the clips (*Fig. 1*).
2. Set proper DC Input Voltage Dip Switch 3: 12VDC ON, 24VDC OFF.
3. Refer to **Dip Switch Selection** and **Jumper Selection Tables** for desired functions (e.g.: Timing, Trigger, Pulse).
4. Measure and verify DC input voltage before powering device to ensure proper operation.
5. Refer to **Terminal Identification Table** and **Typical Applications Fig. 2 through Fig. 9** for desired wiring connections.

Note: When triggering via a N.O. (normally open), momentary or maintained trigger, connect the dry contact trigger to Pos (+) and TRG terminals. When triggering via a N.C. (normally closed), momentary or maintained trigger, connect the trigger to Neg. (-) and TRG terminals and install a resistor [for 12VDC - 2K (2,000 Ohm) or for 24VDC - 4.7K (4,700 Ohm)] between the Pos (+) and TRG terminals (*Fig. 9*).

Dip Switch Selection Table:

Dip #	Off	On
1	Relay energizes at start of timing cycle.*	Relay energizes at the end of timing cycle.*
2	1-60 minutes timing range (adjust trimpot).	1-60 seconds timing range (adjust trimpot).
3	24VDC operating voltage.	12VDC operating voltage.
4	Timing begins immediately upon trigger input.	Timing starts after removal of trigger input.

* When relay energizes (LED is on) [N.O. & C] switch from open to close and [N.C. & C] switch from close to open.

Jumper Selection Table:

Number	Function/Description
J1	Cutting J1 selects the pulser/flasher mode. Relay will flip ON and OFF continuously in equally set timed intervals when timer is powered up.
J2	Cutting J2 puts timer in delayed output mode. Relay will pulse for 1 second at the end of a preset timing cycle. *DIP Switch 1 must be ON for this function.
J3	DTMR1 will go through an initial timing cycle when first powered up unless J3 is cut. If J3 is cut, timing can only be initiated via TRG terminal

Terminal Identification:

Terminal Legend	Function/Description
TRG	Applying a positive voltage will activate timing cycle. Trigger voltage range: 7-12VDC at 12 volt setting, 15-24VDC at 24 volt setting
-, +	Connect 12 or 24VDC filtered and regulated voltage. Refer to Dip Switch Selection Table for voltage setting.
N.O., C, N.C.	Dry form "C" relay contacts are rated 8A at 120VAC/28VDC.

Fig. 1 - ST3 Mechanical Drawing

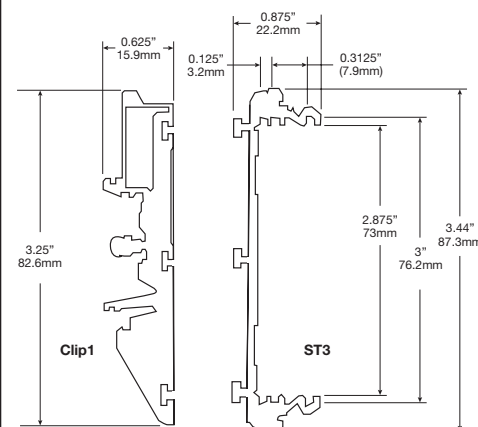

DTMR1 Typical Applications:

Fig. 1 - Timed Door Annunciator:

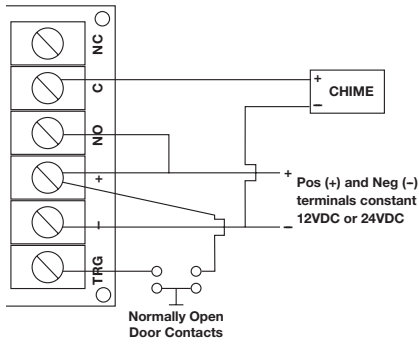

For this application Switch #1 and Switch #4 should be in the OFF position.

Fig. 5 - Timed Door Strike:

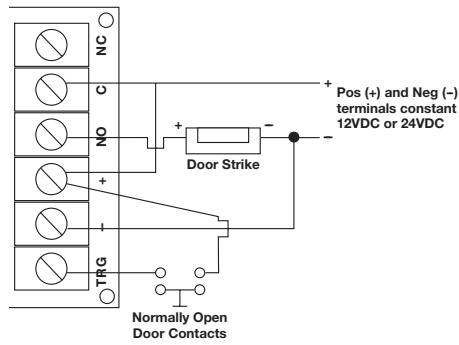

For this application Switch #1 should be in the OFF position and Switch #4 should be in the ON position.

Fig. 2 - Guard Tour Supervisory Timer:

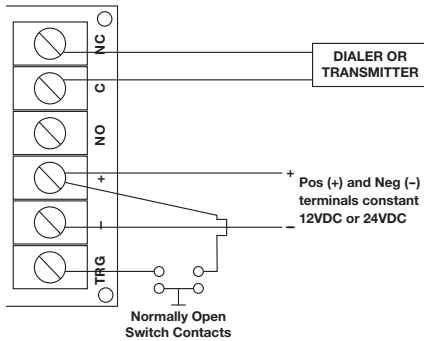

For this application Switch #1 and Switch #4 should be in the OFF position.

Fig. 6 - Timed Shunt for a Door: Use to bypass alarm contacts.

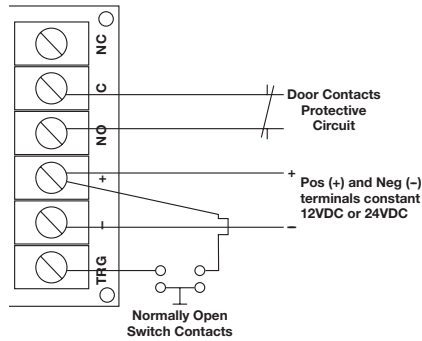

For this application Switch #1 should be in the OFF position and Switch #4 should be in the ON position.

Fig. 3 - Swinger Eliminator:

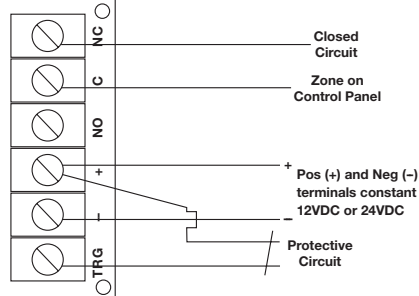

For this application Switch #1 should be in the OFF position and Switch #4 should be in the ON position.

Fig. 7 - Bell Cut Off Timer:

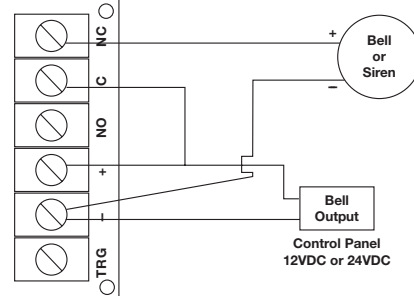

For this application Switch #1 should be in the ON position and Switch #4 is not used in this application.

Fig. 4 - Delay Timer:

Use for Door Ajar Alarm, Delayed Activation of Digital Dialer, Defrost Cycle Timer, etc...

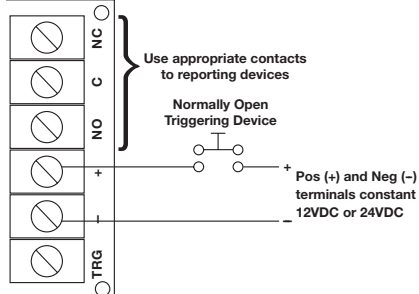

For this application Switch #1 should be in the ON position and Switch #4 is not used in this application.

Fig. 8 - Closed Circuit Trigger Option:

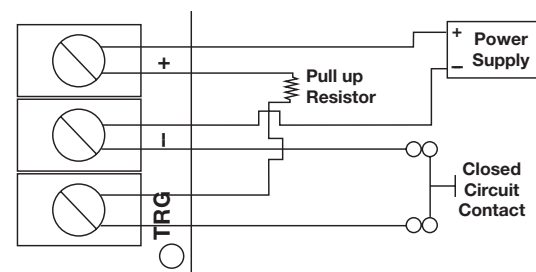

For this application a resistor [for 12VDC - 2K (2,000 Ohm) or for 24VDC - 4.7K (4,700 Ohm)] must be installed as shown (resistor not supplied).

Altronix is not responsible for any typographical errors. Product specifications are subject to change without notice.

140 58th Street, Brooklyn, New York 11220 USA | phone: 718-567-8181 | fax: 718-567-9056

website: www.altronix.com | e-mail: info@altronix.com | Lifetime Warranty

IIDTMR1 - Rev. 101501

J25U

