

ACMS8 Series Sub-Assembly Access Power Controllers

Models Include:

ACMS8

- Eight (8) Fuse Protected Outputs

ACMS8CB

- Eight (8) PTC Protected Outputs

Installation Guide

SECURITY



Rev. 073019



More than just power.™

Overview:

Altronix ACMS8/ACMS8CB are UL listed sub-assemblies to be used in Altronix BC300, BC400, Trove 1 and Trove 2 enclosures and Maximal power units. Input power to ACMS8/ACMS8CB is to be derived from eFlow series power supplies. Access Power Controller's dual input design allows power to be steered from two (2) independent low voltage 12 or 24VDC Altronix eFlow series power supplies to eight (8) independently controlled fuse (ACMS8) or PTC (ACMS8CB) protected outputs. Power outputs of ACMS8(CB) can be converted to dry form "C" contacts. Outputs are activated by an open collector sink, normally open (NO), normally closed (NC) dry trigger input, or wet output from an Access Control System, Card Reader, Keypad, Push Button, PIR, etc. ACMS8(CB) will route power to a variety of access control hardware devices including Mag Locks, Electric Strikes, Magnetic Door Holders, etc. Outputs will operate in both Fail-Safe and/or Fail-Secure modes. The FACP Interface enables Emergency Egress, Alarm Monitoring, or may be used to trigger other auxiliary devices. The fire alarm disconnect feature is individually selectable for any or all of the eight (8) outputs. The spade connectors allow you to daisy chain power to multiple ACMS8(CB) modules. This feature allows you to distribute the power over more outputs for larger systems.

Specifications:

Agency Listings:

- UL 294 7th Edition: Access Control System Units.*
- ULC-S319: Electronic Access Control Systems.**

Input Voltage:

- **Input1:** 12 or 24VDC from eFlow series Altronix Power supply.
- **Input 2:** 12 or 24 VDC from eFlow series Altronix power supply or either 5 or 12 VDC from VR6 Regulator.
- Input Current:
 - ACMS8: 20A total
 - ACMS8CB: 16A total.
- Eight (8) trigger inputs:
 - a) Normally open (NO) inputs (dry contacts).
 - b) Normally closed (NC) inputs (dry contacts).
 - c) Open collector sink inputs.
 - d) Wet Input (5VDC - 24VDC) with 10K resistor
 - e) Any combination of the above.

Outputs:

- **ACMS8:** Fuse protected outputs rated @ 2.5A per output, non power-limited. Total output 20A max. Do not exceed the individual power supply ratings.

See *Input/Output Voltage Ratings*, pg. 6.

ACMS8CB: PTC protected outputs rated @ 2A per output, Class 2 power-limited. Total output 16A max. Do not exceed the individual power supply ratings.

See *Input/Output Voltage Ratings*, pg. 6.

Total output current should not exceed max. current rating of the power supplies employed on each input. See *Maximum Output of Altronix Power Supplies*.

- Eight (8) selectable independently controlled outputs or eight (8) independently controlled Form "C" relay outputs (see below for ratings):
 - a) Fail-Safe and/or Fail-Secure power outputs.
 - b) Form "C" relays rated @ 2.5A. 5, 12, 24VDC, 0.6 Power Factor.
 - c) Auxiliary power outputs (unswitched).
 - d) Any combination of the above.

Outputs (cont'd):

- Individual outputs may be set to OFF position for servicing (output jumper set to middle position). Does not apply to Dry Contact applications.
- Any of the eight (8) fuse/PTC protected power outputs are selectable to follow power Input 1 or Input 2. Output voltage of each output is the same as the input voltage of the input selected. See *Input/Output Voltage Ratings*, pg. 6.
- Surge suppression.

Fire Alarm Disconnect:

- Fire Alarm disconnect (latching or non-latching) is individually selectable for any or all of the eight (8) outputs. Fire Alarm disconnect input options:
 - a) Normally open [NO] or normally closed [NC] dry contact input. Polarity reversal input from FACP signaling circuit.
- FACP input WET is rated 5-30VDC 7mA.
- FACP input EOL requires 10K end of line resistor.
- FACP output relay [NC]: Either Dry 1A/28VDC, 0.6 Power Factor or 10K resistance with [EOL JMP] intact.

Fuse Ratings:

- Main input fuses rated 15A/32V each.
- Output fuses are rated 3A/32V.

LED Indicators:

- Red LEDs indicate outputs are triggered.
- Blue LED indicates FACP disconnect is triggered.
- Individual voltage LED indicates 12VDC (Green) or 24VDC (Red).

Environmental:

- Operating temperature: 0°C to 49°C ambient.
- Humidity: 20 to 93%, non-condensing.

Mechanical:

- Board Dimensions (W x L x H approximate): 7.65" x 4.125" x 1.25" (194.3mm x 104.8mm x 31.8mm).
- Product weight (approx.): 0.7 lb. (0.32 kg).
- Shipping weight (approx.): 0.95 lb. (0.43 kg).

* UL 294 7th Edition Performance Levels: Destructive Attack: I, Endurance: IV, Line security: I, Stand-by power: I.

** ULC-S319: Class 1.

Installation Instructions:

Wiring methods shall be in accordance with the National Electrical Code NFPA 70/NFPA 72/ ANSI / Canadian Electrical Code / CAN/ULC-S524/ULC-S527/ULC-S537, and with all local codes and authorities having jurisdiction. Product is intended for indoor dry use only.

Refer to Sub-Assembly Installation Instruction for mounting Rev. MS050913.

Carefully review:

Terminal Identification Table (pg. 4) **Typical Application Diagram** (pg. 7)
LED Diagnostics (pg. 4) **Hook-up Diagrams** (pg. 8-9)

1. Mount ACMS8/ACMS8CB in the desired location/enclosure. When mounting ACMS8/ACMS8CB alone, use female/female spacers (provided). When mounting with optional VR6 voltage regulator, use female/female spacers (provided) between ACMS8/ACMS8CB and VR6 (Fig. 3, pg. 4). Attach ACMS8/ACMS8CB to spacers utilizing 5/16" pan head screws (provided).
2. Ensure all output jumpers [OUT1] - [OUT8] are placed in the OFF (center) position.
3. Connect low voltage DC power supplies to terminals marked [+ PWR1 -], [+ PWR2 -]
4. Set each output [OUT1] - [OUT8] to route power from power supply 1 or 2 (Fig. 1, pg. 3).

Note: Measure output voltage before connecting devices.
This helps avoiding potential damage.

5. Turn power off before connecting devices.
6. Output options: The ACMS8(CB) will provide up to eight (8) switched power outputs or eight (8) dry form "C" outputs, or any combination of both switched power and form "C" outputs, plus eight (8) unswitched auxiliary power outputs.

Switched Power outputs:

Connect the negative (-) input of the device being powered to the terminal marked [COM].

- For Fail-Safe operation connect the positive (+) input of the device being powered to the terminal marked [NC].
- For Fail-Secure operation connect the positive (+) input of the device being powered to the terminal marked [NO].

Form "C" outputs:

When form "C" outputs are desired, the corresponding jumper (1-8) must be placed in the OFF position (Fig. 1, pg. 3). Alternatively, the corresponding output fuse (1-8) can be removed (ACMS8 only).

Connect negative (-) of the power supply directly to the locking device.

Connect the positive (+) of the power supply to the terminal marked [C].

- For Fail-Safe operation connect the positive (+) of the device being powered to the terminal marked [NC].
- For Fail-Secure operation connect the positive (+) of the device being powered to the terminal marked [NO].

Dry contacts rated @ 2.5A, 28VDC.

Auxiliary Power outputs (unswitched):

Connect positive (+) input of the device being powered to the terminal marked [C] and the negative (-) of the device being powered to the terminal marked [COM]. Output can be used to provide power for card readers, keypads etc.

7. Turn main power on after all devices are connected
8. Input Trigger options:

Note: If Fire Alarm disconnect is not used, connect a 10K ohm resistor to terminals marked [GND and EOL], plus connect a jumper to terminals marked [GND, RST].

Normally Open (NO) Input:

Slide input control logic DIP switch into the OFF position for [Switch 1-8]

(Fig. 2, on right). Connect your wires to terminals marked [+ INP1 -] to [+ INP8 -].

Normally Closed (NC) Input:

Slide input control logic DIP switch into the ON position for [Switch 1-8]

(Fig. 2, on right). Connect your wires to terminals marked [+ INP1 -] to [+ INP8 -].

Open Collector Sink Input:

Connect the open collector sink input to the terminal marked [+ INP1 -] to [+ INP8 -].

Wet (Voltage) Input Configuration:

Carefully observing polarity, connect the voltage input trigger wires and the supplied 10K resistor to terminals marked [+ INP1 -] to [+ INP8 -].

If applying voltage to trigger input - set the corresponding INP Logic to the "OFF" position

If removing voltage to trigger input - set the corresponding INP Logic switch to the "ON" position.

Fig. 1

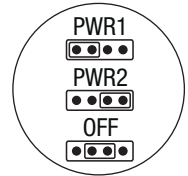
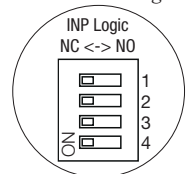

Fig. 2



9. Fire Alarm Interface options:

A normally closed [NC], normally open [NO] input or polarity reversal input from FACP signaling circuit will trigger selected outputs. To enable FACP Disconnect for an output turn the corresponding DIP switch [SW1-SW8] ON. To disable FACP disconnect for an output turn the corresponding DIP switch [SW1-SW8] OFF. Switch is located directly to the left of the Fire Alarm Interface Terminals.

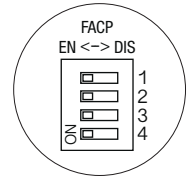

Fig. 3

Normally Open Input:

Wire your FACP relay and 10K resistor in parallel on terminals marked [GND] and [EOL].

Normally Closed Input:

Wire your FACP relay and 10K resistor in series on terminals marked [GND] and [EOL].

FACP Signaling Circuit input trigger:

Connect the positive (+) and negative (-) from the FACP signaling circuit output to the terminals marked [+ FACP -]. Connect the FACP EOL to the terminals marked [+ RET -] (polarity is referenced in an alarm condition).

Non-Latching Fire Alarm Disconnect:

Connect a jumper to the terminals marked [GND, RST].

Latching Fire Alarm Disconnect:

Connect a NO normally open reset switch to terminals marked [GND, RST].

10. FACP Dry NC output:

Connect desired device to be triggered by the unit’s dry contact output to the terminals marked [NC] and [C]. When [EOL JMP] is kept intact, the output is of 0 Ohm resistance in a normal condition. When [EOL JMP] is clipped, a 10k resistance will be passed to next device when in a normal condition.

LED Diagnostics:

ACMS8 and ACMS8CB Access Power Controller

LED	ON	OFF
LED 1- LED 8 (Red)	Output relay(s) de-energized.	Output relay(s) energized.
FACP	FACP input triggered (alarm condition).	FACP normal (non-alarm condition).
Green Output 1-8	12VDC	—
Red Output 1-8	24VDC	—

Terminal Identification Table:

ACMS8 and ACMS8CB Access Power Controller

Terminal Legend	Function/Description
+ PWR1 –	12 or 24 VDC from eFlow power supply.
+ PWR2 –	12 or 24 VDC from eFlow power supply or either 5 or 12 VDC from VR6 regulator.
+ INP1 – through + INP8 –	Eight (8) independently controlled Normally Open (NO), Normally Closed (NC), Open Collector Sink or Wet Input Triggers.
C, NC	FACP Dry NC output rated 1A/28VDC @ 0.6 Power Factor. Class 2 power-limited. With EOL JMP intact, will provide 10k resistance in a normal state.
GND, RST	FACP interface latching or non-latching. NO dry input. Class 2 power-limited. To be shorted for non-latching FACP interface or Latch FACP reset.
GND, EOL	EOL Supervised FACP Input terminals for polarity reversal FACP function. Class 2 power-limited.
– F, + F, – R, + R	FACP Signaling Circuit Input and Return terminals. Class 2 power-limited.
Output 1 through Output 8 NO, C, NC, COM	Eight (8) selectable independently controlled outputs [Fail-Safe (NC) or Fail-Secure (NO)] and eight (8) independently controlled Form “C” Relay outputs.

Input/Output Voltage Ratings

Input Voltage and Source	Output Voltage Rating
5VDC (From VR6 regulator)	5VDC
12V (from VR6 regulator)	12VDC
12VDC (from external power supply)	11.7-12VDC
24VDC (from external power supply)	23.7-24VDC

Maximum Output of Altronix Power Supplies:

UL Listed or Recognized Power Supply	Output Voltage Setting	Max. Output Current
eFlow4NB	12VDC or 24VDC	4A
eFlow6NB	12VDC or 24VDC	6A
eFlow102NB	12VDC	10A
eFlow104NB	24VDC	10A
VR6	5VDC or 12VDC	6A

Typical Application Diagram:

Fig. 5

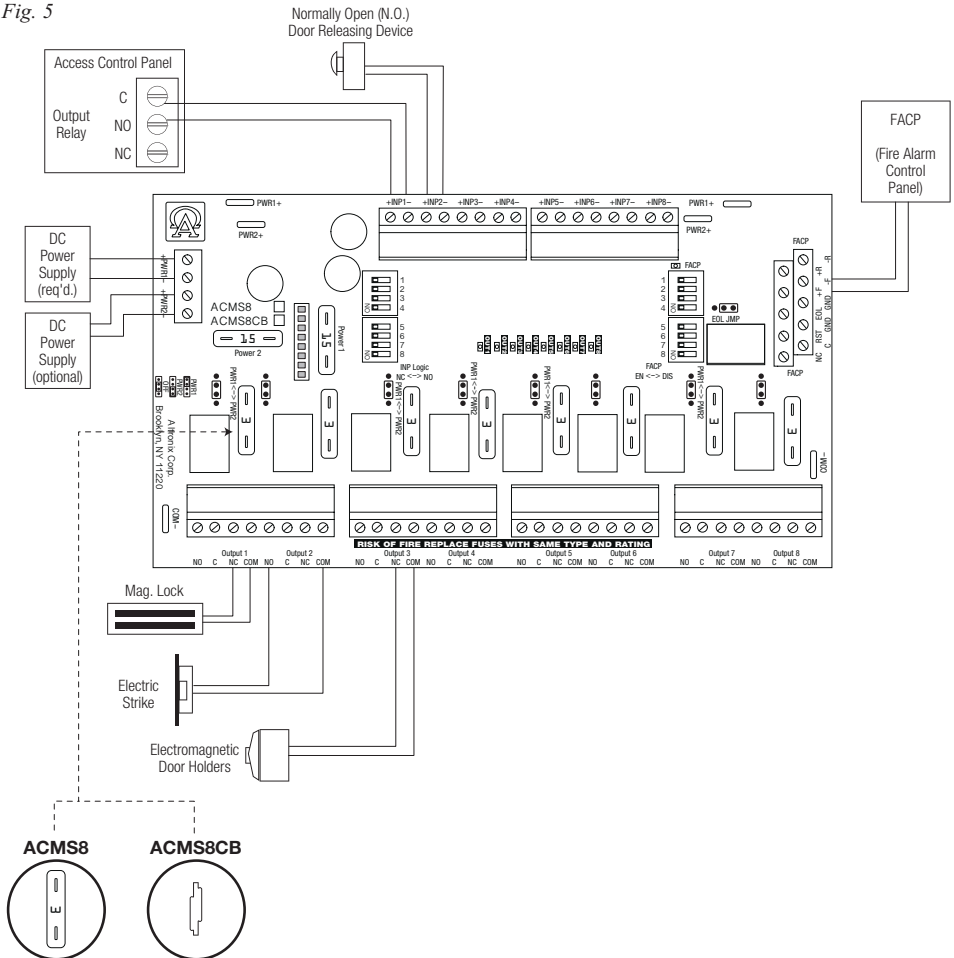

VR6 - Voltage Regulator

Overview:

VR6 voltage regulator converts a 24VDC input into a regulated 5VDC or 12VDC output. It is specifically designed to work with ACMS8(CB) by allowing to mount the Access Power Controller directly on top of VR6 to save enclosure space and simplify connections. Refer to VR6 Installation Guide Rev. 050517.

Specifications:

Power Input / Output:

- Input: 24VDC @ 1.75A – Output: 5VDC @ 6A.
- Input: 24VDC @ 3.5A – Output: 12VDC @ 6A.

Output:

- 5VDC or 12VDC regulated output.
- Output rating 6A max.
- Surge suppression.

LED Indicators:

- Input and output LEDs.

Electrical:

- Operating temperature: 0°C to 49°C ambient.
- Humidity: 20 to 93%, non-condensing.

Mechanical:

- Product weight (approx.): 0.4 lb. (0.18 kg).
- Shipping weight (approx.): 0.5 lb. (0.23 kg).

Connecting ACMS8(CB) to VR6:

1. Fasten male/female spacers (provided) to pems that match the hole pattern for VR6 in the desired location/enclosure. Use metal spacer for the mounting hole with star pattern (Fig. 6a, pg. 7).
2. Plug-in male 8-pin connector to female 8-pin receptacle on VR6 board (Fig. 6, pg. 7).
3. Fasten female/female spacers to male/female spacers (Fig. 6, pg. 7).
Use metal spacers over mounting hole with star pattern (Fig. 6a, pg. 7).
4. Align 8-pin male connector with female receptacle of ACMS8/ACMS8CB, then attach board to spacers utilizing provided 5/16" pan head screws (Fig. 6, pg. 7).
5. Connect 24VDC power supply to terminal marked [+ PWR1 -] of ACMS8/ACMS8CB (Fig. 5, pg. 6).
6. Select output voltage 5VDC or 12VDC using switch [S1] on VR6.
7. Complete steps 4-10 (pgs. 3-4).

Fig. 6

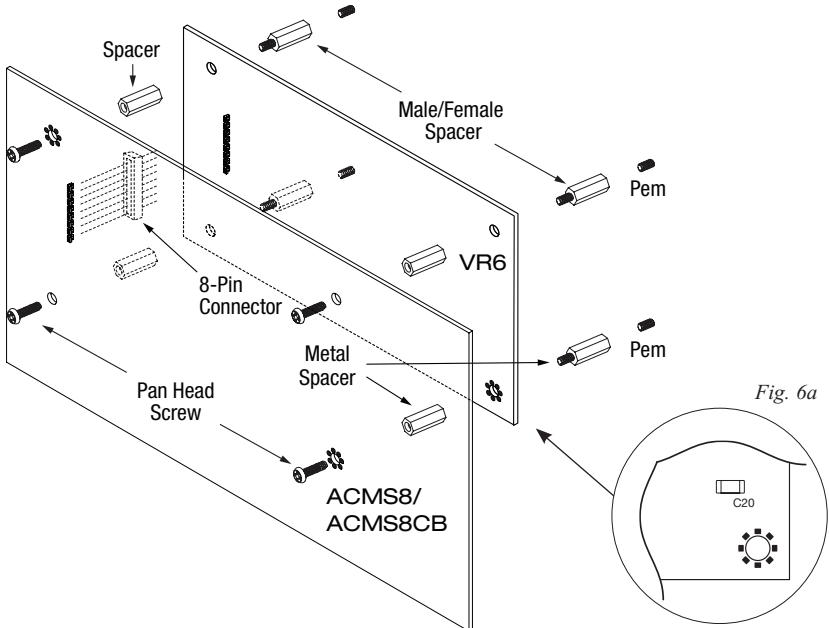

Hook-Up Diagrams:

Fig. 7 - Daisy-chaining one or more ACMS8 units.

EOL Jumper [EOL JMP] should be installed in the EOL position. **Non-Latching.**

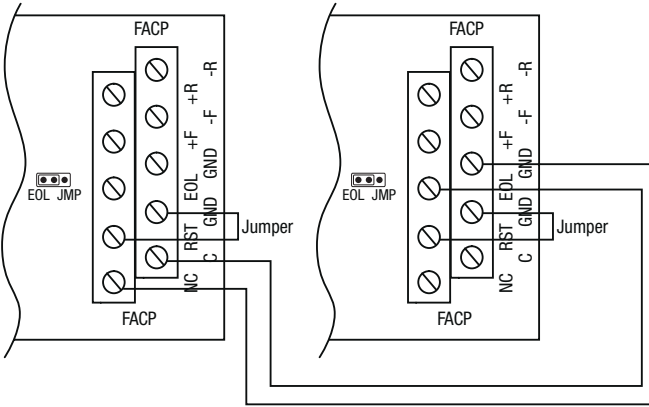

Fig. 8 - Daisy-chaining one or more ACMS8 units.

EOL Jumper [EOL JMP] should be installed in the EOL position. **Latching Single Reset.**

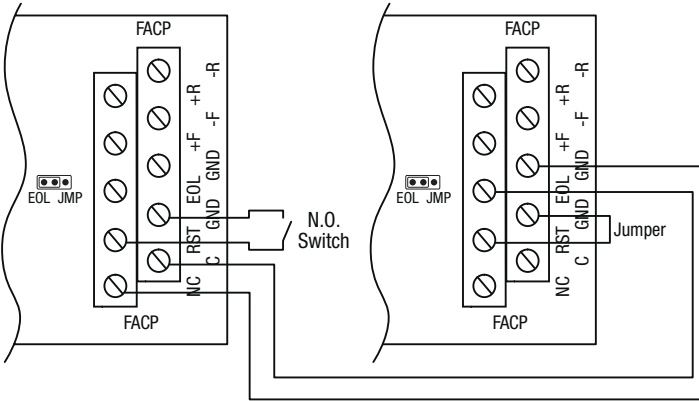
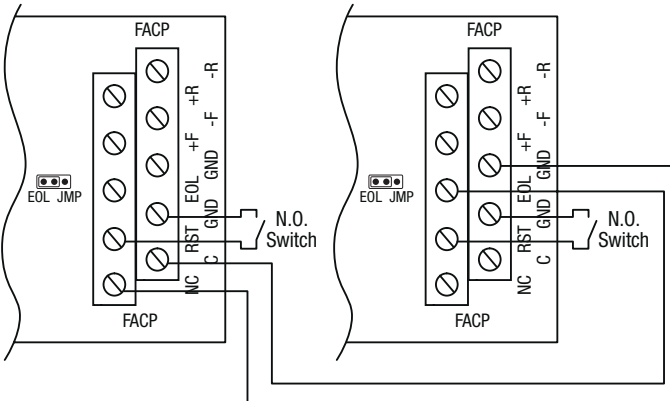

Fig. 9 - Daisy chaining one or more ACMS8 units.

EOL Jumper [EOL JMP] should be installed in the EOL position. **Latching Individual Reset.**



Hook-Up Diagrams:

Fig. 10 - Polarity reversal input from FACP signaling circuit output (polarity is referenced in alarm condition).
Non-Latching.

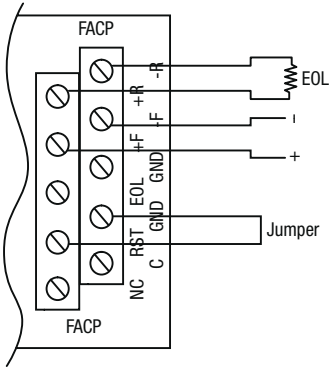

Fig. 11 - Polarity reversal input from FACP signaling circuit output (polarity is referenced in alarm condition).
Latching.

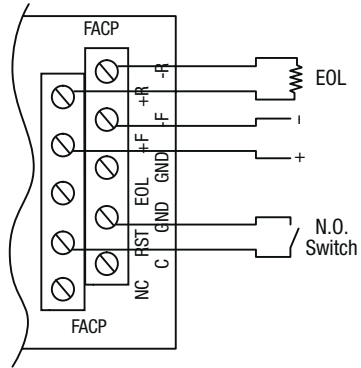

Fig. 12 - Normally Closed trigger input
(Non-Latching).

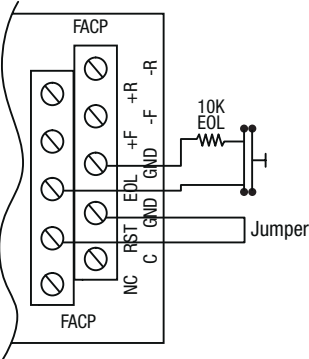

Fig. 13 - Normally Closed trigger input
(Latching).

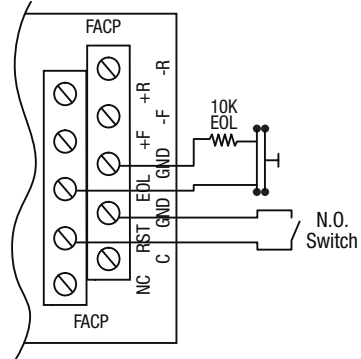

Fig. 14 - Normally Open trigger input
(Non-Latching).

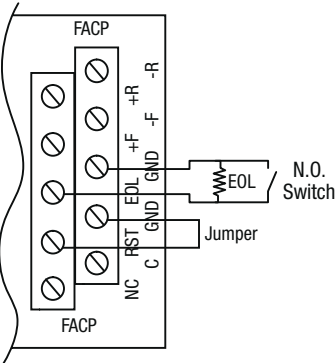
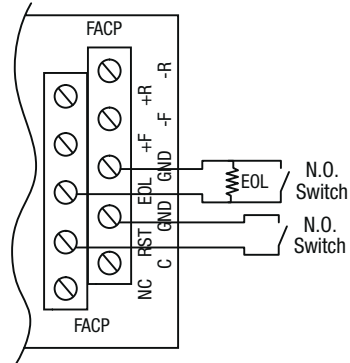

Fig. 15 - Normally Open trigger input
(Latching).



Notes:

Notes:

Notes:

Altronix is not responsible for any typographical errors.

140 58th Street, Brooklyn, New York 11220 USA | phone: 718-567-8181 | fax: 718-567-9056
website: www.altronix.com | e-mail: info@altronix.com | Lifetime Warranty | Made in U.S.A.
IIACMS8/ACMS8CB 111T

