

AL1024X220 Series

Power Supply/Charger

Models Include:

AL1024X220

- Single Output.

AL1024XPD4220

- Four (4) Fuse Protected Outputs.

AL1024XPD8220

- Eight (8) Fuse Protected Outputs.

AL1024XPD16220

- Sixteen (16) Fuse Protected Outputs.

AL1024XPD4CB220

- Four (4) PTC Protected Outputs.

AL1024XPD8CB220

- Eight (8) PTC Protected Outputs.

AL1024XPD16CB220

- Sixteen (16) PTC Protected Outputs.

Installation Guide



Rev. 122905

Installing Company: _____ Service Rep. Name: _____

Address: _____ Phone #: _____



More than just power.™

Overview:

Altronix AL1024X220 is a power supply that converts a nominal 220VAC (working range 198VAC-256VAC) 50/60Hz input to a 24VDC regulating output (see specifications).

AL1024X220 is a base unit for a series of multi-output power supplychargers including: AL1024XPD4220, AL1024XPD4CB220, AL1024XPD8220, AL1024XPD8CB220, AL1024XPD16220, AL1024XPD16CB220 (Refer to **AL1024X220 Series Power Supply Configuration Reference Chart** below).

AL 1024X220 Series Power Supply Configuration Reference Chart:

Altronix Model Number	Accessory Power Distribution Module(s)	Number of Output(s)	Fused Outputs	PTC Outputs (auto-resettable)	Individual Output Rating (A)	Power Supply Battery Fuse Rating	Power Supply Input Fuse Rating
AL1024X(R)220	–	1	–	–	10A	15A/32V	5A/250V
AL1024XPD4220	PD4	4	✓	–	3.5A		
AL1024XPD4CB220	PD4CB		–	✓	2.5A		
AL1024XPD8220	PD8	8	✓	–	3.5A		
AL1024XPD8CB220	PD8CB		–	✓	2.5A		
AL1024XPD16220	Two (2) PD8	16	✓	–	3.5A		
AL1024XPD16CB220	Two (2) PD8CB		–	✓	2.5A		

Specifications:

Agency Listing:

- CE European Conformity.

Input:

- Input 220VAC (working range 198VAC-256VAC), 50/60Hz, 2.5A.

Output:

- 24VDC output.
- 8A supply current with 10A during alarm.
- Filtered and electronically regulated outputs.
- Short circuit and thermal overload protection.

Supervision:

- AC fail supervision (form “C” contacts).
- Low battery supervision (form “C” contacts).
- Battery presence supervision (form “C” contacts).

Battery Backup:

- Built-in charger for sealed lead acid or gel type batteries.
- Automatic switch over to stand-by battery when AC fails.
- Maximum charge current 3.6A.
- Zero voltage drop when switched over to battery backup.

Additional Features:

- AC input and DC output LED indicators.
- Power supply, enclosure, cam lock and battery leads
- All models are available in red enclosure (add an “R” suffix to the part #. e.g. AL1024XPD8R220).

Enclosure Dimensions (H x W x D):

15.5" x 12" x 4.5"

(393.7mm x 304.8mm x 114.3mm).

Stand-by Specifications (total current shown):

Output	15 min. of Stand-by and 5 min. of Alarm	4 hr. of Stand-by and 5 min. of Alarm	24 hr. of Stand-by and 5 min. of Alarm	60 hr. of Stand-by and 5 min. of Alarm
24VDC / 12AH Battery	Stand-By = 8A Alarm = 10A	Stand-By = 1.5A Alarm = 10A	Stand-By = 200mA Alarm = 10A	Stand-By = 100mA Alarm = 10A
Output	15 min. of Stand-by and 5 min. of Alarm	4 hr. of Stand-by and 5 min. of Alarm	24 hr. of Stand-by and 15 min. of Alarm	60 hr. of Stand-by and 15 min. of Alarm
24VDC / 65AH Battery	–	Stand-By = 8.0A Alarm = 10A	Stand-By = 1.5A Alarm = 10A	Stand-By = 500mA Alarm = 10A

For Access Control applications battery capacity for 10A supply current - 1 hr. for 24VDC/12AH battery, 6.5 hrs. for 24VDC/65AH battery.

See battery size calculation worksheet for other batteries (Page 7).

Installation Instructions:

Wiring methods should be in accordance with the National Electrical Code/NFPA 70/NFPA 72/ANSI and with all local codes and authorities having jurisdiction. Product is intended for indoor use only.

1. Mount unit in the desired location. Mark and predrill holes in the wall to line up with the top two keyholes in the enclosure. Install two upper fasteners and screws in the wall with the screw heads protruding. Place the enclosure's upper keyholes over the two upper screws; level and secure. Mark the position of the lower two holes. Remove the enclosure. Drill the lower holes and install the fasteners. Place the enclosure's upper keyholes over the two upper screws. Install the two lower screws and make sure to tighten all screws (*Enclosure Dimensions, pg. 8*). Secure enclosure to earth ground.
2. Connect AC circuit (220VAC, 50/60Hz) as follows: Green branch wire connects to earth (safety) ground lug . Line and Neutral to the connector on power supply board marked [L, N] respectively (*Fig. 1, pg. 4*). Use 14 AWG or larger for all power connections (Battery, DC output, AC input). Use 22 AWG to 18 AWG for power-limited circuits (AC Fail/Low Battery reporting).
3. Measure output voltage before connecting devices. This helps avoiding potential damage.

Keep power-limited wiring separate from non power-limited wiring (220VAC 50/60Hz Input, Battery Wires). Minimum 0.25" spacing must be provided.

CAUTION: Do not touch exposed metal parts. Shut branch circuit power before installing or servicing equipment. There are no user serviceable parts inside. Refer installation and servicing to qualified service personnel.

4. Connect devices to be powered:
 - a. For Power Supply Board: connect to the terminals marked [+ DC -] (*Fig. 1, pg. 4*).
 - b. For Power Distribution Module(s): connect devices to be powered to the terminal pairs 1 to 4 marked [1P & 1N] through [4P & 4N] (*Fig. 2, pg. 6*) or 1 to 8 marked [1P & 1N] through [8P & 8N] (*Fig. 3, pg. 6*), carefully observing correct polarity.
Note: When servicing the unit, AC mains should be removed.
5. For Access Control applications batteries are optional. When batteries are not used, a loss of AC will result in the loss of output voltage. When the use of stand-by batteries is desired, they must be lead acid or gel type.
6. Connect appropriate signaling notification devices to terminals marked [AC FAIL] and [BAT FAIL] (*Fig. 1, pg. 4*) supervisory relay outputs.
Note: When used in fire alarm, burglar alarm or access control applications, "AC Fail" relay must be used to provide a visual indication of AC power on.
7. Please ensure that the cover is secured with the provided key lock.

Wiring:

Use 14 AWG or larger for all power connections.

Note: Take care to keep power-limited circuits separate from non power-limited wiring (220VAC, Battery).

Maintenance:

Unit should be tested at least once a year for the proper operation as follows:

Output Voltage Test: Under normal load conditions the DC output voltage should be checked for the proper voltage level.

Battery Test: Under normal load conditions check that the battery is fully charged, check specified voltage both at the battery terminal and at the board terminals marked [- BAT +] to ensure that there is no break in the battery connection wires.

Note: Maximum charging current under discharges is 3.6A.

Note: Expected battery life is 5 years; however, it is recommended changing batteries in 4 years or less if needed.

Fig. 1 - AL1024X220 Series

CAUTION: De-energize unit prior to servicing.

For continued protection against risk of electric shock and fire hazard replace fuse with the same type and rating. Do not expose to rain or moisture.

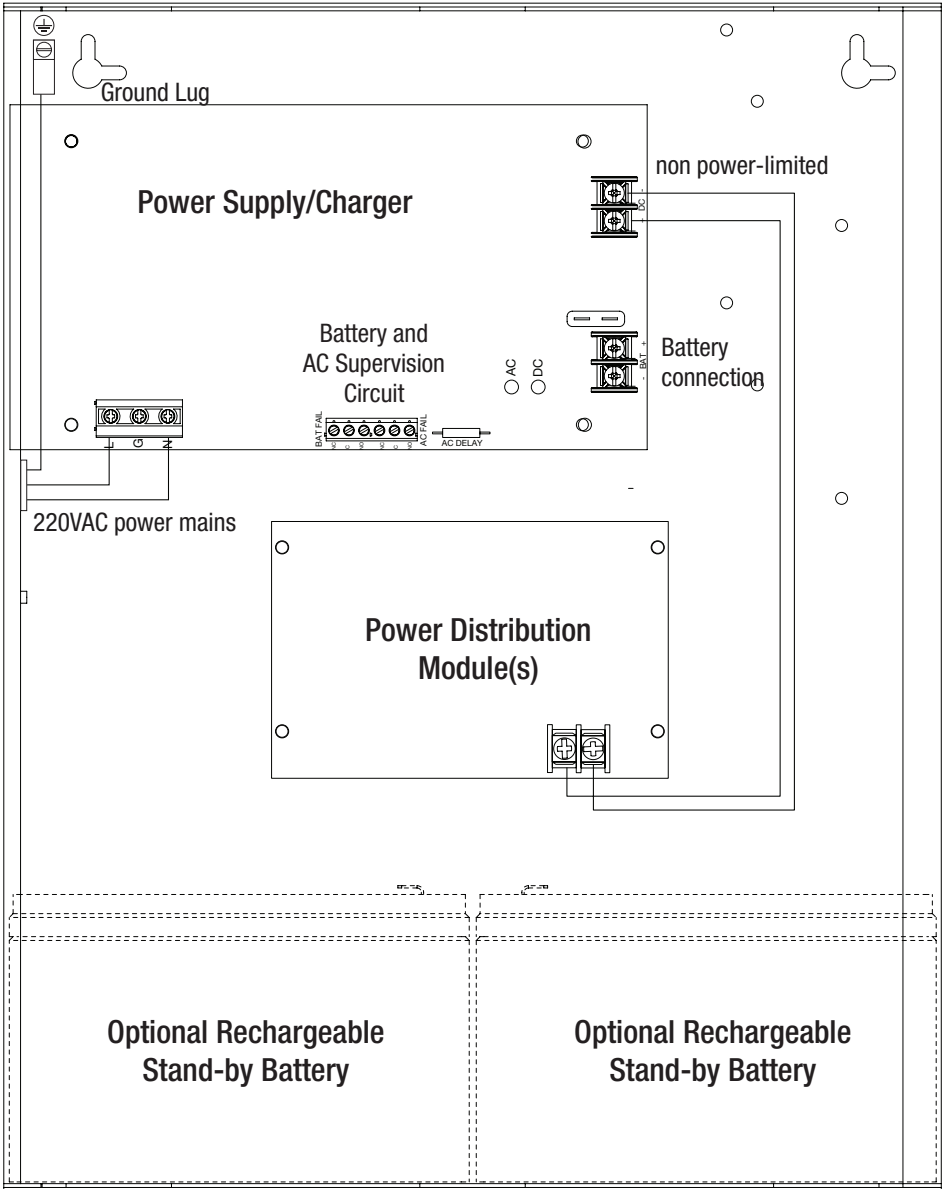

CAUTION: Optional rechargeable stand-by batteries must match the power supply output voltage setting.

Keep power-limited wiring separate from non power-limited. Use minimum 0.25" spacing.

LED Diagnostics:

Power Supply Board

Red (DC)	Green (AC)	Power Supply Status
ON	ON	Normal operating condition.
ON	OFF	Loss of AC. Stand-by battery supplying power.
OFF	ON	No DC output.
OFF	OFF	Loss of AC. Discharged or no stand-by battery. No DC output.

Power Distribution Module

Green	Power Distribution Module Status
ON	Normal operating condition.
OFF	No Power Output.

Terminal Identification:

Power Supply Board

Terminal Legend	Function/Description
L, N	Connect 220VAC (working range 198VAC-256VAC), 50/60Hz to these terminals: L to hot, N to neutral.
+ DC –	24VDC @ 8A continuous, 10A in alarm non power-limited output. 10A continuous when batteries are not used
AC Fail NC, C, NO	Indicates loss of AC power, e.g. connect to audible device or alarm panel. Relay normally energized when AC power is present. Contact rating 1A @ 28VDC. AC or brownout fail is reported within 1 minute of event. To delay reporting for up to 6 hrs., cut “AC delay” jumper and reset power to unit.
Bat Fail NC, C, NO	Indicates low battery condition, e.g. connect to alarm panel. Relay normally energized when DC power is present. Contact rating 1A @ 28VDC. A removed battery is reported within 5 minutes. Battery reconnection is reported within 1 minute. Low battery threshold: 24VDC output threshold set @ approximately 21VDC.
– BAT +	Stand-by battery connections. Maximum charge current 3.6A.

Power Distribution Module

Terminal Legend		Function/Description
PD4/PD4CB	PD8/PD8CB	
1P to 4P	1P to 8P	Positive DC power outputs.
1N to 4N	1N to 8N	Negative DC power outputs.

Power Distribution Module(s):

Fig. 2a - PD4 Power Distribution Board
Fuse Protected Outputs

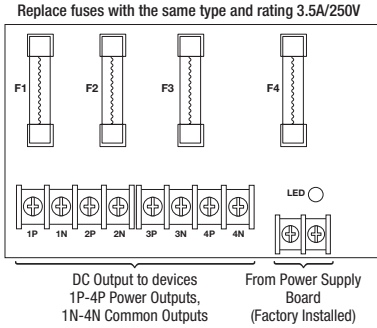

Fig. 2b - PD4CB - Power Distribution Board
PTC Protected Outputs

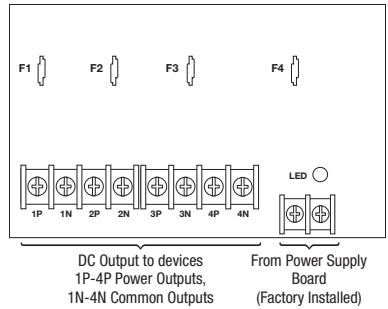

Fig. 3a - PD8 Power Distribution Board
Fuse Protected Outputs

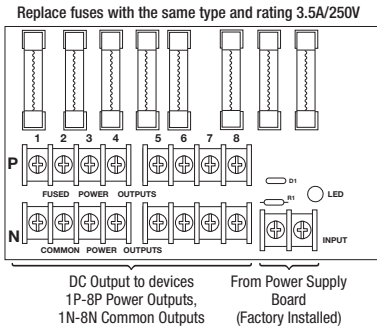
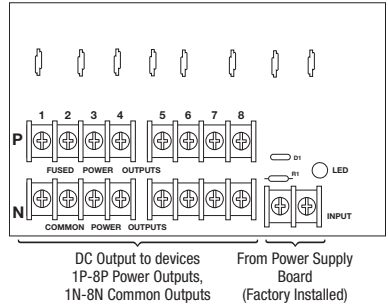

Fig. 3b - PD8CB - Power Distribution Board
PTC Protected Outputs



Battery Size Calculation Worksheet:

A. AL1024X220 series internal current consumption	(stand-by)	_____	0.05 A
B. Load current consumption	(stand-by)	_____	A
C. Stand-by time required (hours)		_____	H
D. Battery capacity required for stand-by	$(A+B)*C$	_____	AH
E. AL1024X220 series internal power consumption	(Alarm)	_____	0.05 A
F. Load current consumption	(Alarm)	_____	A
G. Alarm duration (Hours; 15 Min. = 0.25 Hour)	(Alarm)	_____	H
H. Battery capacity required for Alarm	$(E+F)*G$	_____	AH
I. Total calculated battery capacity	$D+H$	_____	AH
J. Battery capacity required	$I*1.8$ (safety factor)	_____	AH

Note: AL1024X220 series power supply is designed to work with batteries up to 65AH.

Please note: line [J] must not exceeds 36AH.

You have to reduce either stand-by current consumption or stand-by time in order to comply with requirement.

To determine actual battery size please round line [J] to the nearest larger standard battery size (e.g. 3.5 AH = 4.0 AH).

Enclosure Dimensions (BC400):

15.5" x 12" x 4.5" (393.7mm x 304.8mm x 114.3mm)

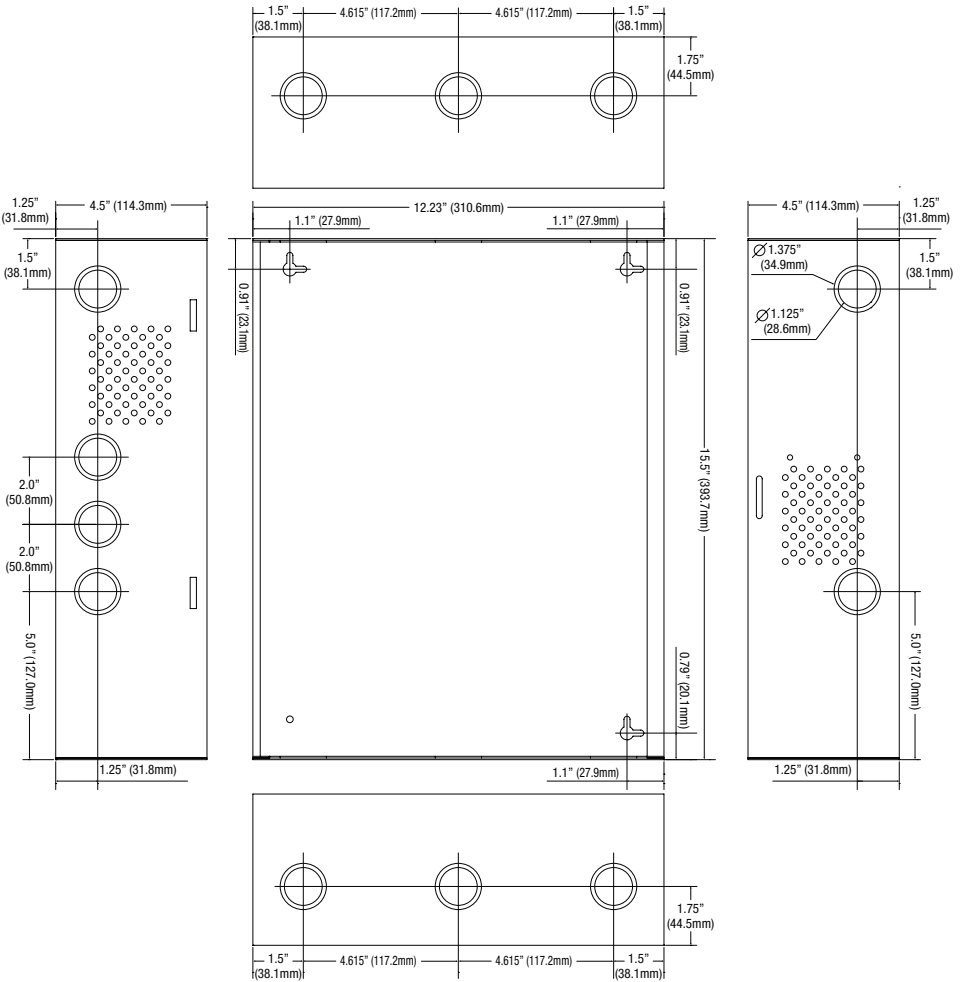

Altronix is not responsible for any typographical errors.

140 58th Street, Brooklyn, New York 11220 USA | phone: 718-567-8181 | fax: 718-567-9056
 website: www.altronix.com | e-mail: info@altronix.com | Lifetime Warranty
 IIAL1024X220 Series G09U

