

4K/UHD, 8x2 Multi-Format Matrix Switcher with Dual, HDBaseT and Mirrored HDMI Outputs

AT-UHD-CLSO-824

User Manual



Please check <http://www.atlona.com/product/AT-UHD-CLSO-824> for the most recent **firmware update** or **manual**.

Table of Contents

1. Introduction	3
2. Package Contents	3
3. Features	3
4. Wall/Rack Mounts	3
5. Panel Descriptions	
a. Front Panel	4
b. Back Panel	4
6. Category Cable	5
7. Analog Multi-Format Inputs	6
8. Audio Connections	7
9. Microphone	8
10. Front Panel Display	9-10
11. TCP/IP and GUI	11-21
12. IR	22
13. RS-232	23-28
16. Connection Diagram	29
14. Control Drivers	29
15. CLSO-824 Updates	29
17. Specifications	30
18. Safety	31
19. Warranty	32-33
20. Registration	33

Update - Rev C - May 2016

- Pg. 20 Added HDVS-200 and control parameters
- Pg. 24 Added RS-232 'HDVS sta' command to give HDVS status information
- Pg. 24 Added RS-232 'System sta' command to give all CLSO status information

Introduction

The Atlona AT-UHD-CLSO-824 is an 8x2, 4K/UHD matrix switcher with multi-format signal-handling, Ethernet-enabled, 100M HDBaseT™ input/output extension, and advanced audio capabilities.

Package Contents

- 1 x AT-UHD-CLSO-824
- 13 x Female Captive Screw Connectors
 - 6 pin: audio (x3), MIC/Line (x2), RS-232 (x5) - 5 pin: IR (x1) - 3 pin: RS-232 (x1) - 2 pin: power (x1)
- 1 x 48V/3.125A DC power supply
- 1 x Pair of dual purpose wall/rack mounts
- 1 x IR Remote Control
- 1 x User manual

Features

- Three HDBaseT inputs for remote sources
- Four HDMI inputs (accepts DVI and DisplayPort with adaptors)
- Multifunctional VGA ports for VGA, RGBHV, and component sources
- Stereo or mono audio input for line or microphone (dynamic or phantom powered) sources
- PoE output to power compatible transmitters (**e.g.** AT-HDVS-200-TX) and receivers (**ex.** AT-UHD-EX-100CE-RX)
- Balanced audio input for embedding audio
- EDID management options including internal and learned EDID
- Balanced (+4 dBu) analog audio output for de-embedding audio to amplifiers or audio systems
- Control via RS-232, IR, TCP/IP, webGUI and front panel
- Multi-channel audio pass through up to Dolby TrueHD® or DTS-HD Master Audio™ on HDMI and HDBaseT
- Internal audio mixer for active digital sources and two independent analog sources
- Master and sub volume control
- 5 band audio output EQ to ensure the best speaker performance
- IP to RS-232 conversion enables TCP/IP commands to be sent using RS-232 ports
- Independent audio switching enables analog audio input to be embedded on any video input
- Multiple RS-232 ports for source or other device control
- HDCP compliant and management

Wall/Rack mounts

A pair of mounts are included for quick and easy installation in a rack or to a shelf or wall. To install the CLSO-824 in a rack, use the screws already in the case (A-pictured below)

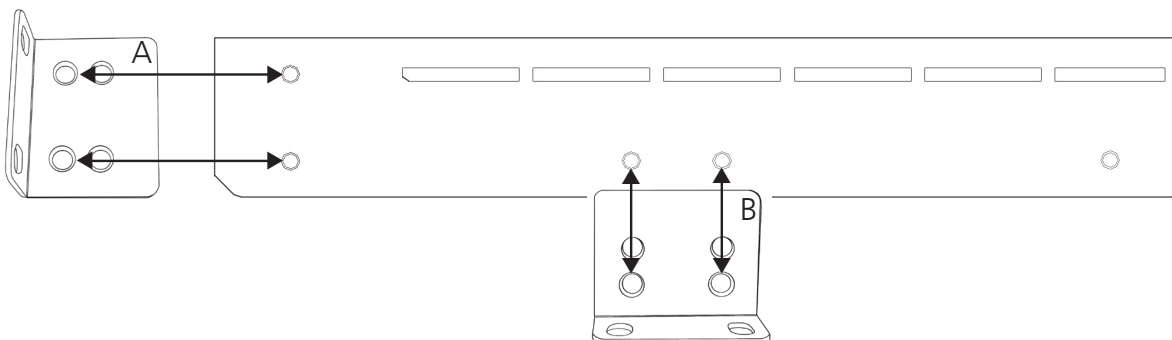

To install the CLSO-824 on a wall or under a desk/table, use the screws already in the case (B - pictured above)

Panel Description

Front Panel

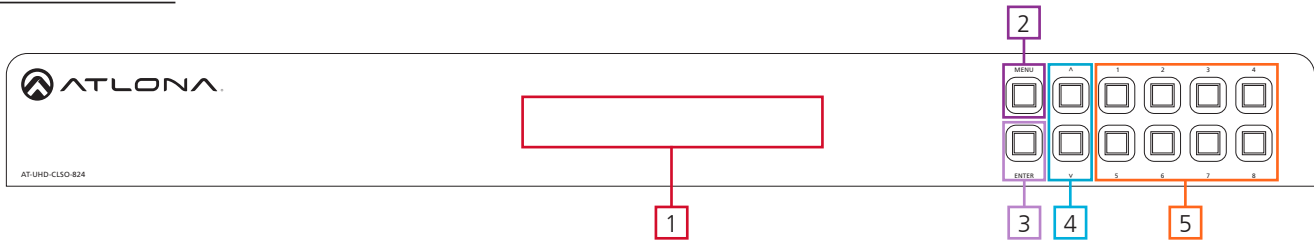

1. LED screen - Front panel LED display for status and control
2. Menu - Access the front panel setup controls - also used within the menu as a back button
3. Enter - Select options within the front panel control menu

Note: Menu and Enter pressed and held for at least 3 seconds will put unit in standby

4. ^ and v - Use to navigate between selections within the front panel control menu
5. Numeric Keys - Switch between inputs and outputs
 - 1 - HDBaseT input 1 - Used while updating MCU firmware
 - 2 - HDBaseT input 2
 - 3 - HDBaseT input 3 - Used while updating DSP firmware
 - 4 - HDMI input 4 - Used while updating FPGA firmware
 - 5 - HDMI input 5 - Used while updating the TX (HDBaseT output) firmware
 - 6 - HDMI input 6 - Used while updating the RX (HDBaseT input) firmware
 - 7 - HDMI input 7
 - 8 - Multifunction VGA input 8

Back Panel

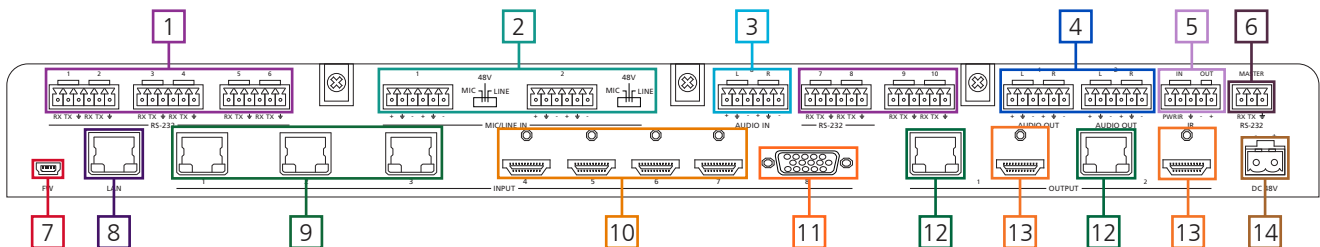

1. RS-232 ports - Control for external devices - send or receive RS-232 or TCP/IP commands
2. MIC/LINE IN - Connect a microphone or audio sources
MIC Switch - Match input to type of microphone or audio source being used
3. Audio In - Connect audio source to be embedded to the analog video input
4. Audio Out - Audio output to audio amplifiers (e.g. AT-PA100-G2) or audio systems
5. IR IN/OUT - Switcher IR control ports
6. Master RS-232 - Connect control system to control the switcher
7. Firmware port - Connect to a PC with a USB cable for firmware updating
8. LAN port - TCP/IP (Ethernet) port, connect to router, computer, or control device
9. HDBaseT 1 through 3 - Connect compatible PoE HDBaseT transmitters (e.g. AT-HDVS-200-TX)
10. HDMI 4 through 7 - Connect HDMI sources (DVI or DisplayPort compatible with adaptors)
11. VGA 8 - Connect analog video sources
Note: Compatible with VGA, RGBHV and component signals
12. HDBaseT Outputs - Connect to compatible HDBaseT displays or compatible receivers (e.g. AT-UHD-EX-100CE-RX)
13. HDMI Outputs - Connect to local display or extenders (e.g. AT-UHD-EX-100CE-KIT)
14. DC 48V port - Connect included power supply

Category Cable

For the category cables used in the installation of these products, please be sure to use a 568B termination as pictured below:

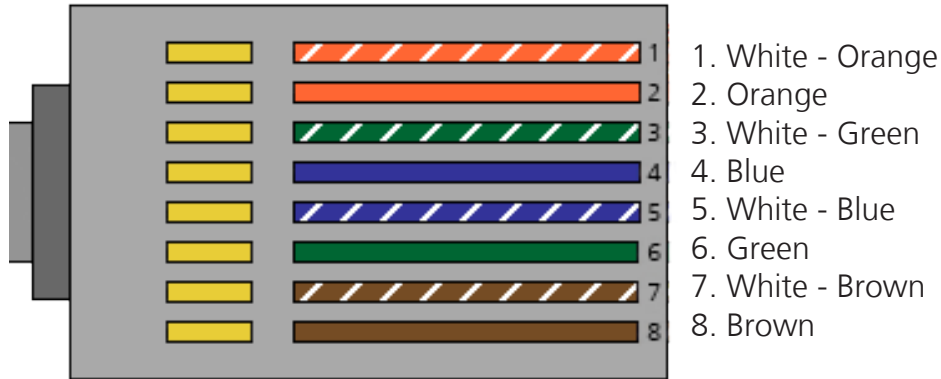

Use the table below to verify the best category cable for the installation.

Performance Rating		Type of LAN cable	
Wiring	Shielding	CAT5e/6	CAT6a/7
Solid	Shielded (STP/FTP)	***	****
	Unshielded (UTP)	**	N/A
Stranded - Patch cable (Not recommended)	Unshielded (UTP)	*	N/A
	Shielded (STP/FTP)	*	N/A
Termination		Please use EIA/TIA-568-B termination	

Important! 4K (UHD) signals are sensitive to cable quality and installation technique. It is recommended to use CAT6a/7 solid core cables for best results.

Note: For cable distances see the specifications on page 30

Connector

Connector type and size is very important to ensure extenders work correctly. Please use the matching cable type with the correct RJ45 connector.

CAT5e cables should use only CAT5e RJ45 connectors

CAT6 cables should use only CAT6 connectors

CAT6a cables should use only CAT6a connectors

CAT7 cables should use only CAT7 connectors

Using the wrong size connectors may result in interference causing loss of signal.

Important! "EZ RJ45 connectors" are not recommended with HDBaseT extenders. Doing so may result in interference with audio and video transmission.

Analog Multi-Function Inputs

The CLSO-824 multi-function analog inputs (Input 8) can be used with analog video signal formats including VGA (with DDC), RGBHV (without DDC), and component (YUV). Balanced analog audio can be input and embedded using the provided captive screw connectors.

Either format can be directly accessed from RS-232, IR, or IP control. It can also be accessed through the front panel menu.

VGA (m) to BNC and VGA (m) to RCA adaptors can be used to connect sources to this inputs.

VGA

Use a VGA to VGA cable to ensure that the Preferred Resolution DDC is communicated to your source.

RGBHV

Use a HD-15 (VGA) to 5 BNC breakout cable for this format. An existing RGBHV analog matrix switch can be connected here to maintain full function of the analog matrix.

Component

YUV (YPbPr) signal from DVD (or other sources) can be input to the CLSO-824 using the green (Y), blue (Pb), and red (Pr) connections on a HD-15 (VGA) to 5 BNC breakout cable or with a VGA - 3 RCA adaptor.

A common application for this type of input would be to connect a RGBHV matrix switcher to the CLSO-824.

Captive Screw

The captive screw connectors allow you to cut cables to a suitable length, reducing cable clutter while providing a more reliable connection.

Connecting

When connecting the cables to the female captive screw connector it is important that the wires be terminated correctly. The female captive screw connector has a contact plate at the top and must have the wires touching it for signal to pass. When wired correctly (see picture A) the signal will pass, incorrectly (see picture B) no signal will pass.

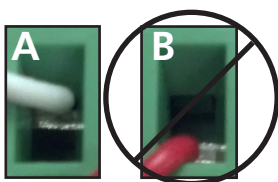

The captive screw connectors have a contact bar that is adjusted to compress the wire against the top contact plate. Use the screws at the top of the connector to compress the wire against the contact plate.



Clockwise
Turn the screws clockwise to raise the contact bar to the upper contact plate and hold the wires in place.



Counter Clockwise
Turn the screws counter clockwise to lower the contact bar to release the wires.

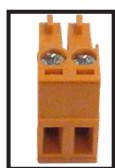

Power



Black: - White: +

The power cable (picture 1) will have exposed wires. Each wire is encased in a different colored cover.

Analog Audio

A captive screw analog audio connector is provided to ensure a more reliable and secure connection. The captive screw connector supports balanced and unbalanced audio input and output.

Balanced audio connections use two signal wires and a ground to minimize interference to an audio signal over longer cable runs. Unbalanced audio connections use two wires for connection with consumer audio components.

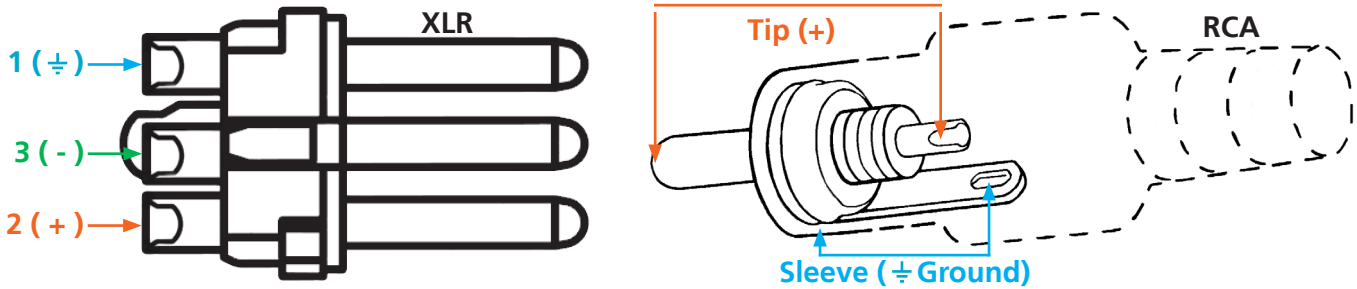

Note: Pin outs may vary, please refer to the audio device's manual to ensure a correct connection.

Important! When terminating cables, please ensure exposed adjacent wires do not touch. This may result in a short that can damage connected devices.

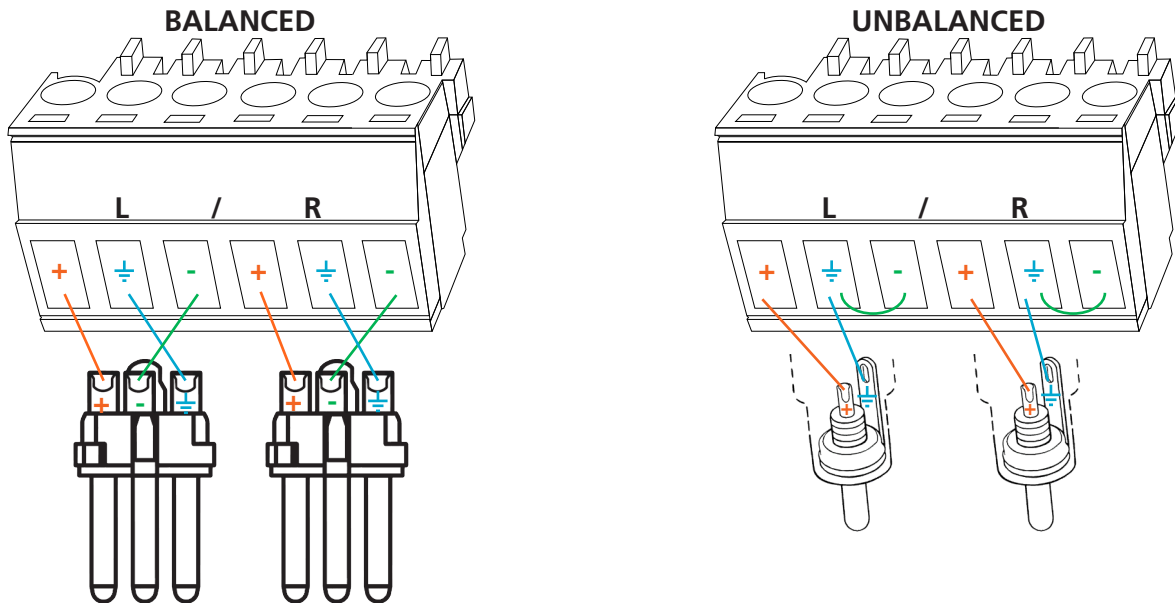

Important! With unbalanced connections a jumper is needed between ground and negative to reduce noise

Microphone Connection

MIC (Dynamic MIC)

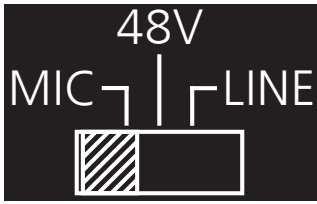

Connect dynamic or self-powered microphones in this mode.

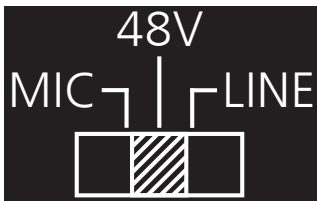
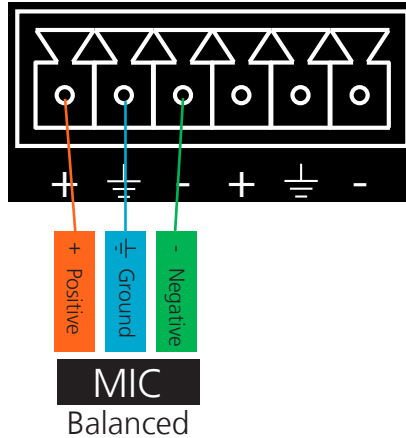

Use this setting for phantom powered microphones. Supplies 48 volts.

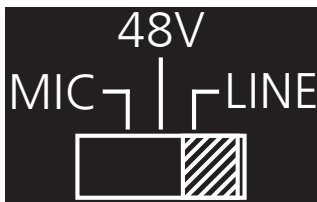
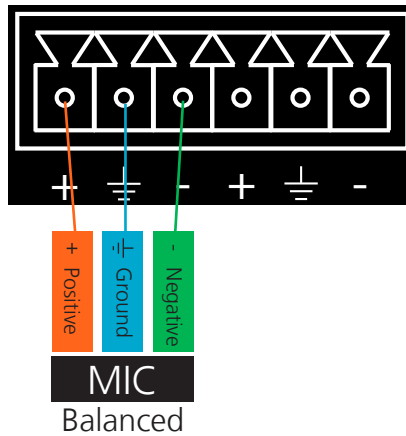

Connect wireless microphone receivers (or other sources) with line level outputs using this setting. Either balanced, unbalanced, mono, or two channel connections may be used.

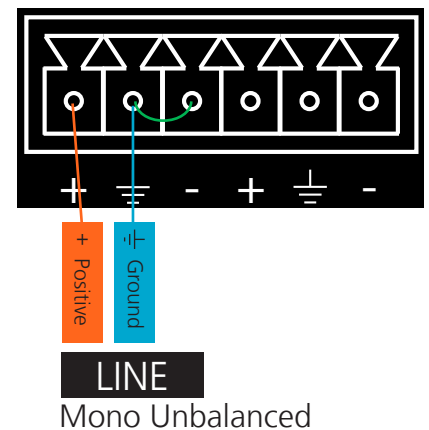
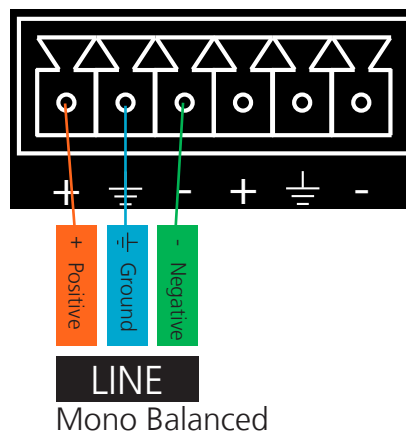
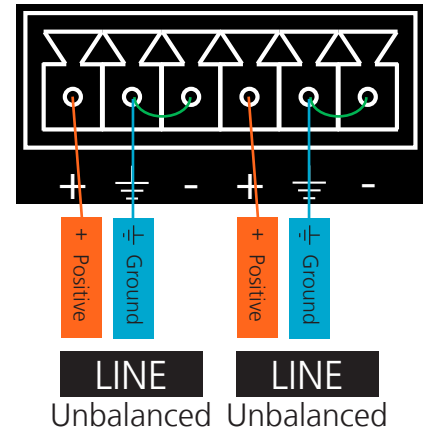
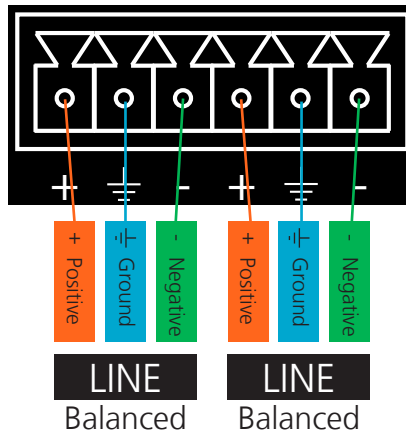

Front Panel Control

Although the Web GUI is recommend for complete setup, many functions can also be completed using the front panel buttons and display. See page 11 for GUI operation. Use the menu button to access the menu. Once in the menu, use the enter button to select options, the up/down arrows to navigate, number buttons for selecting the inputs and outputs, and the menu button for going back one level of the menu.

Route Setting	Route Default					
	Route All	Select route source: #	1 to 8			
	Recall memory	Select memory route: #	1 to 8			
	Save memory	Select memory route: #	1 to 8			
	VGA mode	Select mode:	comp			
			vga			
Audio Setting	Audio Route	Select output number: #	1 or 2	Audio Route Out #	AFV	
				(Program Audio Source)	AFOV	
					AUX 1	
					AUX 2	
		Audio preset	Save to preset: #	1 to 4		
		Aux Mixer	Select output number: #	1 or 2	ON	
					OFF	
		Input volume	Input volume	HDBT1		
	HDBT2					
	HDBT3					
	HDMI4					
	HDMI5					
	HDMI6					
HDMI7						
VGA8						
	Ducking	Select output number: #	1 or 2	ON		
				OFF		
	Audio delay	Select output number: #	1 or 2	0 to 150 ms		
	EQ	Select output number: #	1 or 2	<120Hz	-12 to 15 dB	
				500Hz	-12 to 15 dB	
				1.2kHz	-12 to 15 dB	
				3kHz	-12 to 15 dB	
				7.5kHz	-12 to 15 dB	
	Audio Mono	Select output number: #	1 or 2	ON		
				OFF		

Audio ducking, delay and EQ adjust audio settings of HDMI, HDBaseT, and analog audio outputs.

Audio mono adjusts analog audio outputs only. These settings and adjustments to not change pass-through multichannel PCM, Dolby and DTS signals.

EDID Setting	EDID Mode	Select input port: #	1 to 7	1. Default	Select memory number: #	
				2. Memory		Source # Mode: Int
				3. Int		Default
						ATL 2160P60 Multi CH
						ATL 2160P60 2CH
						ATL 2160P30 Multi CH
						ATL 2160P30 2CH
						ATL 1920x1200 RGB 2CH
						ATL 1080P DD
						ATL 1080P Multi CH
						ATL 1080P 2CH
						ATL 1080P 3D DD
						ATL 1080P 3D Multi CH
						ATL 1080P 3D 2CH
						ATL 1080P DVI
	ATL 1280x800 RGB 2CH					
	ATL 1280x800 RGB DVI					
	ATL 1366x768 RGB 2CH					
	ATL 1024x768 RGB 2CH					
	ATL 720P DD					
	ATL 720P 2CH					
	800x600 RGB 2CH					
	EDID copy	Select output number: #	1 to 4	Save to Memory: #	1 to 8	
	Prefer Timing	Select input port: #	8	Default		
				1920x1200		
				1920x1080		
				1280x800		
				1366x768		
				1024x768		
				1280x720		
				800x600		
IR Settings	IR Receiver	1. On				
		2. Off				
Reset	-----					
Info	MCU FW ver: VX.XX.XX					
	Valens FW ver: VX.X					
	FPGA FW ver: VX.X					
	DSP FW ver: VX.X					
	IP					
	X.X.X.X					
	NetMask					
	X.X.X.X					
Gateway						
X.X.X.X						
TCP/IP port						
XX						
Console						
XXXXX, X, X, X						

EDID settings can be set for the HDMI and HDBaseT ports.
 Prefer Timing can be set to the VGA port only.

TCP/IP

For convenience, the CLSO-824 comes with DHCP on. This enables the switcher to be connected to a network without concern for overlapping IP addresses with other devices on the network. If your network does not support DHCP, this feature may be turned off and the IP address set using RS-232 commands.

Note: If your system is controlled using IP, it is strongly recommended that you disable DHCP and select an unused IP address so that your system controller doesn't lose contact with the switcher.

TCP/IP and WebGUI Setup

Atlona has created an easy to use webGUI for initial setup and later changes to the configuration of the CLSO-824.

To begin, connect the LAN port of the CLSO-824 to your network. Type the IP address of the CLSO-824 into the web browser of a PC connected to the same network (as seen below).

To find the switcher IP: Select "Info" on the front panel display or use RS-232 command "IPCFG".

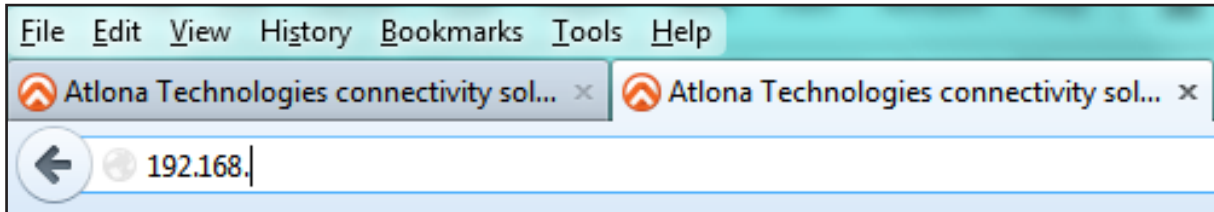

Important: If any stability issues are experienced, disable any anti-virus or firewall that may interfere with network communication to the switcher. Once set up is done and the switcher GUI is no longer being used, the firewall and anti-virus can be re-enabled.

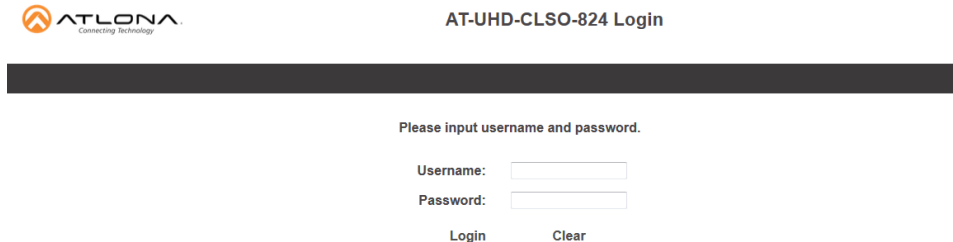
A screenshot of the login screen for the AT-UHD-CLSO-824. At the top left is the Atlona logo. At the top right is the text 'AT-UHD-CLSO-824 Login'. Below this is a black horizontal bar. Underneath the bar, the text 'Please input username and password.' is displayed. There are two input fields: 'Username:' and 'Password:'. Below the 'Password:' field are two buttons: 'Login' and 'Clear'.

A login screen will appear (this is the same log in for admin and general users). For the first log in (and future admin changes) the username is "root" and password is "Atlona".

Note: Only the admin password can be changed (see page 15). The username will always remain "root".

System Info.	
Model:	AT-UHD-CLSO-824
Software Revision:	1.0.15
On-Time(h-m):	63:59

Output1 Video Info.	
Input:	INPUT 4
Signal Type:	--
Video Format:	--
Aspect:	--
Color Space:	--
Color Depth:	--

Output1 Audio Info.	
Input:	HDMI 4
Audio Format:	
Sampling Rate:	
Channels:	

Output2 Video Info.	
Input:	INPUT 5
Signal Type:	--
Video Format:	--
Aspect:	--
Color Space:	--
Color Depth:	--

Output2 Audio Info.	
Input:	HDMI 5
Audio Format:	
Sampling Rate:	
Channels:	

The information is very useful when trouble-shooting your installation. It includes information on the switcher, connect sources, and outputs.

Home	Network Setup	Settings	Config	EDID	Audio	HDVS	Update
DHCP	<input checked="" type="radio"/> ON		<input type="radio"/> OFF				
IP Address	<input type="text" value="192.168.011.090"/>						
Subnet	<input type="text" value="255.255.255.000"/>						
Gateway	<input type="text" value="192.168.011.001"/>						
Telnet Port	<input type="text" value="23"/>						
Login Mode	<input type="radio"/> ON		<input checked="" type="radio"/> OFF				
MAC Address	B8-98-B0-00-4C-20						

The network set up page will allow the IP information to be changed. When a change is made the screen will grey and the ability to save or cancel will display at the bottom (see below).

Note: When DHCP is on, the IP address cannot be configured. Turn DHCP off to enable IP configuration.

Note: For a stable connection when using a control system, it is best to set up a static IP. When selecting an IP address, make certain no other devices on your network are using that IP address.

Note: Be sure to save all changes before moving to the next page.

DHCP	<input checked="" type="radio"/> ON		<input type="radio"/> OFF				
IP Address	<input type="text" value="192.168.000.117"/>						
Subnet	<input type="text" value="255.255.255.000"/>						
Gateway	<input type="text" value="192.168.000.001"/>						
Telnet Port	<input type="text" value="23"/>						
Login Mode	<input checked="" type="radio"/> ON		<input type="radio"/> OFF				
MAC Address	B8-98-B0-00-00-01						
Save Setting				Cancel			

Login Mode has been added to provide a secure telnet login. Once Login Mode has been turned on a username and password will be required on all IP connections to the switcher.

Note: Login mode should be in off position when the CLSO is used with control systems that do not support passwords. If your control system supports password protection, set the login mode to on. The GUI always requires a password.

Note: The username and password used in IP Login Mode will be the same login information as the webGUI.

System Settings	
Power	ON ▾
Panel Lock	Unlock ▾

Route Settings	
Output 1	Input 4 ▾
Output 2	Input 5 ▾

VGA Settings	
Mode	VGA ▾

Factory Default

The settings page is used to set system and audio/video options.

System Settings

Power - Turn the switcher on and off
 Panel Lock - Locks/unlocks the front panel buttons

Route Settings

Output 1 - Select source to route to HDBaseT and HDMI output 1
 Output 2 - Select source to route to HDBaseT and HDMI output 2

VGA Settings

Mode - Switch between VGA and component

Note: RGBHV can be used when VGA is selected

Factory Default

It will reset parameters. Confirm Cancel

Factory Default

Select to reset CLSO back to factory settings.

Note: This will reset the switcher to factory default, including: resolutions, audio settings, HDCP settings, etc.

Change user name and password:

Old user name and password	
Username	<input type="text" value="root"/>
Password	<input type="password"/>
New user name and password	
Username	<input type="text"/>
Password	<input type="password"/>
PW again	<input type="password"/>

No.	Username	Password	Delete
User 1			Delete
User 2			Delete
User 3			Delete

RS232	Baudrate	Databit	Parity	Stopbit
System	115200	8 Bits	None	1 Bit
RS232-1	115200	8 Bits	None	1 Bit
RS232-2	115200	8 Bits	None	1 Bit
RS232-3	115200	8 Bits	None	1 Bit
RS232-4	115200	8 Bits	None	1 Bit
RS232-5	115200	8 Bits	None	1 Bit
RS232-6	115200	8 Bits	None	1 Bit
RS232-7	115200	8 Bits	None	1 Bit
RS232-8	115200	8 Bits	None	1 Bit
RS232-9	115200	8 Bits	None	1 Bit
RS232-10	115200	8 Bits	None	1 Bit
VALENS-IN1	115200	8 Bits	None	1 Bit
VALENS-IN2	115200	8 Bits	None	1 Bit
VALENS-IN3	115200	8 Bits	None	1 Bit
VALENS-OUT1	115200	8 Bits	None	1 Bit
VALENS-OUT2	115200	8 Bits	None	1 Bit

[Factory Default](#)

From the Config page the admin password can be changed, users added, and the RS-232 ports to be configured. CLSO-824 system port, the RS-232 I/O ports, and the HDBaseT/Valens ports can be adjusted individually. RS-232 ports must be configured to match the device to which they are connected. For example, the system port should match the settings of the control system, the individual port settings should match the devices connected to them. The CLSO-824 will adjust the signal from the control system to match the output device.

Note: User information will display for the admin only.

Note: Only the admin password can be changed. The admin username will always remain "root". If the admin password is lost the system must be returned to factory settings and setup repeated.

RS232	Baudrate	Databit	Parity	Stopbit
System	115200	8 Bits	None	1 Bit
RS232-1	115200	8 Bits	None	1 Bit
RS232-2	2400	8 Bits	None	1 Bit
RS232-3	4800	8 Bits	None	1 Bit
RS232-4	7200	8 Bits	None	1 Bit
RS232-5	9600	8 Bits	None	1 Bit
RS232-6	14400	8 Bits	None	1 Bit
RS232-7	19200	8 Bits	None	1 Bit
RS232-8	38400	8 Bits	None	1 Bit
RS232-9	57600	8 Bits	None	1 Bit
RS232-10	115200	8 Bits	None	1 Bit
VALENS-IN1	128000	8 Bits	None	1 Bit
VALENS-IN2	230400	8 Bits	None	1 Bit
VALENS-IN3	115200	8 Bits	None	1 Bit
VALENS-OUT1	9600	8 Bits	None	1 Bit
VALENS-OUT2	9600	8 Bits	None	1 Bit
VALENS-OUT1	115200	8 Bits	None	1 Bit
VALENS-OUT2	115200	8 Bits	None	1 Bit

Home Network Setup Settings Config EDID Audio HDVS Update

Input:		
Input 1	Default	▼
Input 2	Default	▼
Input 3	Default	▼
Input 4	Default	▼
Input 5	Default	▼
Input 6	Default	▼
Input 7	Default	▼
Input 8	Default	▼

Output:		
Output 1	memory	Please select ▼
Output 2	memory	Please select ▼
Output 3	memory	Please select ▼
Output 4	memory	Please select ▼

HDCP Settings	
Input 1:	Compliant ▼
Input 2:	Compliant ▼
Input 3:	Compliant ▼
Input 4:	Compliant ▼
Input 5:	Compliant ▼
Input 6:	Compliant ▼
Input 7:	Compliant ▼

Default

- ATL 2160P60 Multi CH
- ATL 2160P60 2CH
- ATL 2160P30 Multi CH
- ATL 2160P30 2CH
- ATL 1920x1200 RGB 2CH
- ATL 1080P DD
- ATL 1080P Multi CH
- ATL 1080P 2CH
- ATL 1080P 3D DD
- ATL 1080P 3D Multi CH
- ATL 1080P 3D 2CH
- ATL 1080P DVI
- ATL 1280x800 RGB 2CH
- ATL 1280x800 RGB DVI
- ATL 1366x768 RGB 2CH
- ATL 1024x768 RGB 2CH
- ATL 720P DD
- ATL 720P 2CH
- ATL 800x600 RGB 2CH

Factory Default

The EDID page provides the option to adjust the EDID of the HDMI and HDBaseT ports, select the preferred timing of the VGA port, and set the HDCP compliance reporting.

- Note:** If no audio is being received, try adjusting EDID. If the CLSO does not receive a complete EDID and the HDMI port will default to DVI (which has no audio).
- Note:** 2Ch audio EDID is recommended unless the system is being used as an audio pass through.
- Note:** CLSO-824 protects HDCP encoded content and will not pass HDCP content to a non-HDCP compliant device.
- Note:** Some devices flag all content as protected when connected to an HDCP compliant display. This prevents what should be non-protected content from reaching non-compliant devices (**e.g.** teleconference system) through the CLSO-824.
- Note:** When HDCP reporting is non-compliant, only user created content is transmitted. Protected content from all sources (**e.g.** Blu-ray, AppleTV, etc.) is blocked.
- Note:** These functions are also controllable using TCP/IP or RS-232 commands.

Master Volume	
Output 1	<input type="text"/> dB
Output 2	<input type="text"/> dB

Sub Volume	
Video 1	<input type="text"/> dB
Video 2	<input type="text"/> dB
Video 3	<input type="text"/> dB
Video 4	<input type="text"/> dB
Video 5	<input type="text"/> dB
Video 6	<input type="text"/> dB
Video 7	<input type="text"/> dB
VGA	<input type="text"/> dB
AUX 1	<input type="text"/> dB
AUX 2	<input type="text"/> dB

Master Volume

Output 1 adjusts the audio level of the embedded audio on HDBaseT output 1, HDMI output 1, and analog output 1. Output 2 adjusts the audio level of the embedded audio on HDBaseT output2, HDMI output 2, and analog output 2.

Sub Volume

Volume control for each input and the Aux (MIC/48V/Line) inputs. These are typically used to match audio levels from all sources.

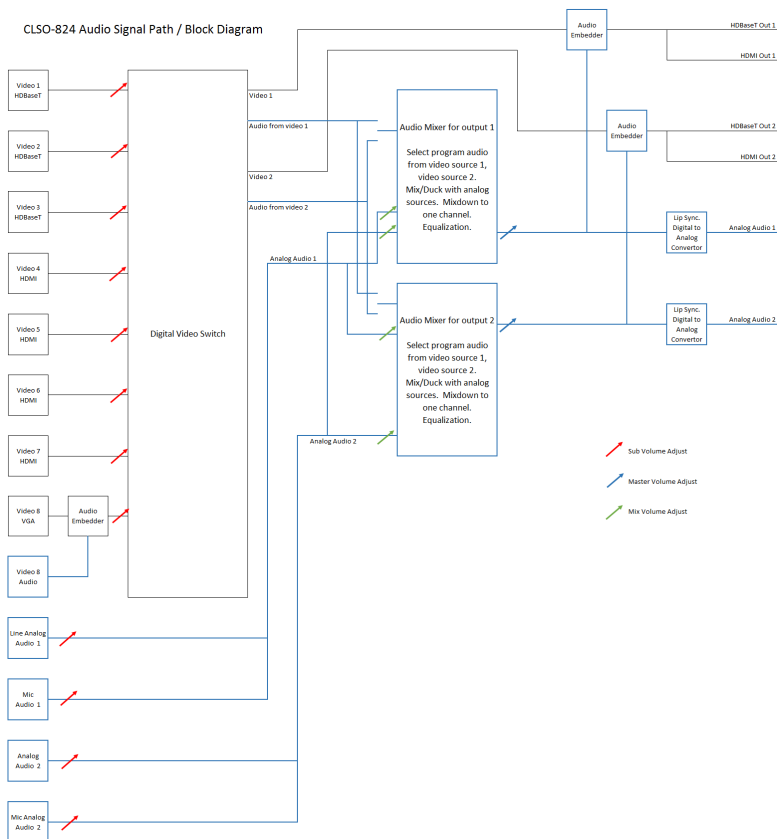

Audio output 1 configuration	
Source	AFV <input type="button" value="v"/> Bitstream
Ducking	Disable <input type="button" value="v"/>
Attack Time	<input type="text" value=""/> ms
Release Time	<input type="text" value=""/> ms
Program Decrease	<input type="text" value=""/> dB
DownMix	Disable <input type="button" value="v"/>
Mixer	<input type="checkbox"/> AUX 1 LINE 1 <input type="text" value=""/> dB
	MIC 1 <input type="text" value=""/> dB
	<input type="checkbox"/> AUX 2 LINE 2 <input type="text" value=""/> dB
	MIC 2 <input type="text" value=""/> dB
Lipsync	<input type="text" value=""/> ms

Audio output 2 configuration	
Source	AFV <input type="button" value="v"/> Non-Bitstream
Ducking	Disable <input type="button" value="v"/>
Attack Time	300 ms <input type="range" value="300"/>
Release Time	1000 ms <input type="range" value="1000"/>
Program Decrease	20 dB <input type="range" value="20"/>
DownMix	Disable <input type="button" value="v"/>
Mixer	<input checked="" type="checkbox"/> AUX 1 LINE 1 <input type="text" value="0"/> dB <input type="range" value="0"/>
	MIC 1 <input type="text" value="0"/> dB <input type="range" value="0"/>
	<input checked="" type="checkbox"/> AUX 2 LINE 2 <input type="text" value="0"/> dB <input type="range" value="0"/>
	MIC 2 <input type="text" value="0"/> dB <input type="range" value="0"/>
Lipsync	0 ms <input type="range" value="0"/>

Audio output 1 configuration

Source - Select between **A**udio **F**ollow **V**ideo (HDMI/HDBaseT OUT 1), **A**udio **F**ollow **O**ther **V**ideo (HDMI/HDBaseT OUT 2), Aux 1 (MIC/Line IN 1), Aux 2 (Mic/Line IN 2)

Ducking - Enable - Ducking automatically changes the source (AFV/AFOV) volume
 Disable - Mixing enabled

Attack time - Sets delay before the ducking begins after detecting signal from a microphone

Release time - Sets delay time after no signal is detected that ducking stops

Program decrease - Set amount to ensure the program level is low enough so when ducking is triggered the speaker/audio is heard

Down mix - Enable/disable - Sets AUX source to mix output mono (enabled) or two channel (disabled)

Mixer - Mix analog audio sources with program audio

Lipsync - Adjust lipsync to compensate for multiple scalers after the CLSO-824 which may delay video without delaying audio. It is not intended to compensate for errors in source material

Audio output 2 configuration follows the same configuration as output 1 except for in source

Source - **A**udio **F**ollow **V**ideo (HDMI/HDBaseT OUT 2), **A**udio **F**ollow **O**ther **V**ideo (HDMI/HDBaseT OUT 1), Aux 1 (MIC/Line IN 1), Aux 2 (Mic/Line IN 2)

EQ Output 1		
Band 1 (120Hz)	0 dB	
Band 2 (500Hz)	0 dB	
Band 3 (1200Hz)	0 dB	
Band 4 (3000Hz)	0 dB	
Band 5 (7500Hz)	0 dB	

EQ Output 2		
Band 1 (120Hz)	0 dB	
Band 2 (500Hz)	0 dB	
Band 3 (1200Hz)	0 dB	
Band 4 (3000Hz)	0 dB	
Band 5 (7500Hz)	0 dB	

Ducking output 1 settings		
Microphone	ON	
Trig Level	-35 dB	

Ducking output 2 settings		
Microphone	ON	
Trig Level	-35 dB	

EQ Output

Settings adjust the equalization for the audio outputs of both analog and embedded audio. The center frequency for each listed. Nominal position is centered at 0 dB. 5 band EQ adjustment for HDMI/HDBaseT output ports.

Ducking Output Settings

Microphone - Turns ducking on/off

Trig Level - Sets volume level of microphone at which ducking is triggered

Ducking Setup

Note: Proper set up is critical for satisfactory operation. If program levels are too high they can trigger the ducking process. Microphone ducking uses the audio level from the microphone to decrease the program level so the speaker may be heard. Setting the microphone volume too high may result in feedback. It is recommended that a handheld or headset microphone be used with ducking to reduce feedback and maximize the difference between voice and program levels. Best results are received with the following sequence:

1. Set master volume to 0. (This is 10 db below maximum)
2. Raise appropriate microphone (or line in) volume until just below feedback or adequate volume is reached (whichever setting is lower). - Master level and amplifier gains may be increased to get appropriate levels
- Note:** If feedback occurs and volume is not adequate, move the speakers and/or microphone to eliminate feedback.
3. Raise source "sub" volumes to appropriate levels without talking
4. Set attack time to minimize popping, but still fast enough that initial talking sounds are heard.
5. Set release time so that program levels do not increase between sentences. Note: Shorten time so that the microphone doesn't interfere with the program.
6. Set the trigger level so that words spoken at a normal level trigger the ducking process Note: Set the trigger level too sensitive and the program will trigger the ducking. Set too low and the speaker will have to talk very loudly to trigger ducking. The further right the slider is, the more sensitive the setting.
7. Set program decrease to ensure when ducking is triggered the program level is low enough the speaker can be heard.

Fine tuning these settings will help achieve the best results.

Input 1

Model Name HDVS-200TX
IP Link [192.168.11.232](#)

Input 2

1 Unknown Refresh 2
 Input Selection Hdmi 1 3
 Preferred Resolution 800x600 4
 Auto Switch Off 5
 Display Switch Unknown Disable Display Switch 6

Input 3

Unknown Refresh
 Input Selection Hdmi 1
 Preferred Resolution 800x600
 Auto Switch Off
 Display Switch Unknown Disable Display Switch

HDVS Page

Input 1

Model Name: Displays model number of connected transmitter

IP Link: Displays IP link to compatible transmitter's webGUI

Input 2 & 3 -

1. Displays model number of connected HDVS transmitter
2. Refresh button - Update to ensure the current settings are displayed
3. Input selection - Switch between the HDVS inputs
4. Preferred resolution - Sets the HDVS VGA port preferred input resolution
5. Auto switch - Turns auto switching on/off for the HDVS transmitter
6. Display switch - Sets display switch function of the HDVS (default is AVS)
Recommended set to disabled - product will be always on

The HDVS-200-TX or HDVS-200-TX-WP have display control buttons that generate RS-232 codes sent over the HDBaseT connection to the CLSO-824.

Using the programming language of your control system, you can use the string to trigger a macro with the actions your system design requires. Typical macros could turn on the display or be used as a "show me" button.

When the display button is pressed the command `#*PORTx[WP_Display[Off]]$CRCR` or `#*PORTx[WP_Display[On]]$CRCR` will be sent to the RS-232 master port on the CLSO.

Note: _{CR} = carriage return x= zone number

When connecting or disconnecting HDBaseT devices to the CLSO (such as HDVS-200) the CLSO will send query commands to get device type information: `RS232zoneX[WP_Display[?]]$CRCR`

TCP/IP Settings of Controlled Device	
Broadcast	On <input type="button" value="Save"/>
IP Mode	Non-Login
IP Address	192.168.5.80 <small>Please set your device to static IP address.</small>
Port	23
Username	admin
Password	admin

Setting these parameters will route the HDVS display commands from the HDVS through the CLSO to the control system/PC at the designated IP address.

Home	Network Setup	Settings	Config	EDID	Audio	HDVS	Update
<div style="border: 1px solid black; padding: 5px;"> <p>Firmware Update</p> <p><input type="button" value="Browse..."/> No file selected. <input type="button" value="Upload"/></p> <p style="text-align: center;">0%</p> </div>							
<div style="border: 1px solid black; padding: 5px;"> <p>Audio Update</p> <p><input type="button" value="Browse..."/> No file selected. <input type="button" value="Upload"/></p> <p style="text-align: center;">0%</p> </div>							
<div style="border: 1px solid black; padding: 5px;"> <p>FPGA Update</p> <p><input type="button" value="Browse..."/> No file selected. <input type="button" value="Upload"/></p> <p style="text-align: center;">0%</p> </div>							

The update page provides an easy way to update switcher firmware.

Download the most current firmware from <http://atlona.com/product/AT-UHD-CLSO-824/>. Once the firmware is saved on the computer use the browse button to select the correct file. Press the update button and a progress bar will display. If a restart of the CLSO-824 is required, the webGUI will display a prompt.

Remote

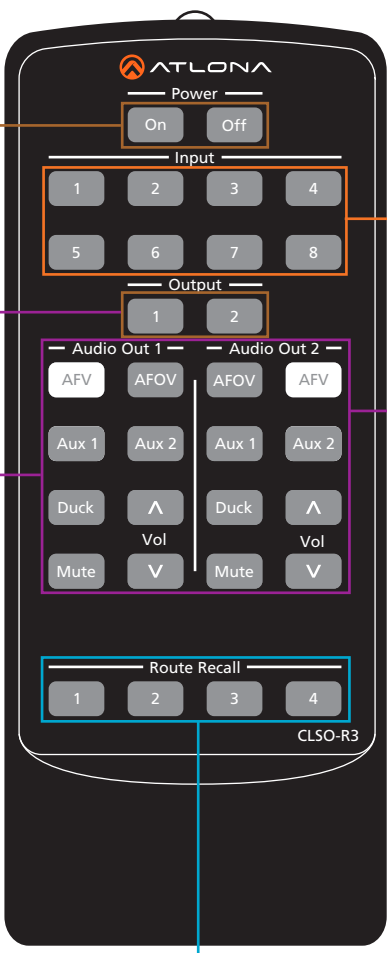

Power
On - takes CLSO-824 on
Off - sets CLSO-824 to standby

Output
1 - HDMI and HDBaseT output 1
2 - HDMI and HDBaseT output 2

Audio Out 1
AFV - Audio is de-embedded from HDMI/HDBaseT output 1
AFOV - Audio is de-embedded from HDMI/HDBaseT output 2
Aux 1 - Select audio from MIC/48V/Line input 1
Aux 2 - Select audio from MIC/48V/Line input 2
Duck - Selects ducking mode for AUX sources over selected embedded audio. Toggles to mix mode.
Mute - Silences all audio 1 outputs
Volume - Adjust volume

Source Selection
1 - HDBaseT 1
2 - HDBaseT 2
3 - HDBaseT 3
4 - HDMI 4
5 - HDMI 5
6 - HDMI 6
7 - HDMI 7
8 - VGA 8

Audio Out 2
AFV - Audio is de-embedded from HDMI/HDBaseT output 2
AFOV - Audio is de-embedded from HDMI/HDBaseT output 1
Aux 1 - Select audio from MIC/48V/Line input 1
Aux 2 - Select audio from MIC/48V/Line input 2
Duck - Selects ducking mode for AUX sources over selected embedded audio. Toggles to mix mode.
Mute - Silences all audio 2 outputs
Volume - Adjust volume

Route Recall
Recalls previously saved input/output routes

System IR is typically used to connect to control system processors. This input is used to control the CLSO-824.

Note: The IR receiver is optional for the UHD-CLSO-824. The compatible IR receiver (AT-IR-CS-RX) can be purchased through atlonac.com.

The wires of the emitter and receiver have been marked to differentiate the pin outs.

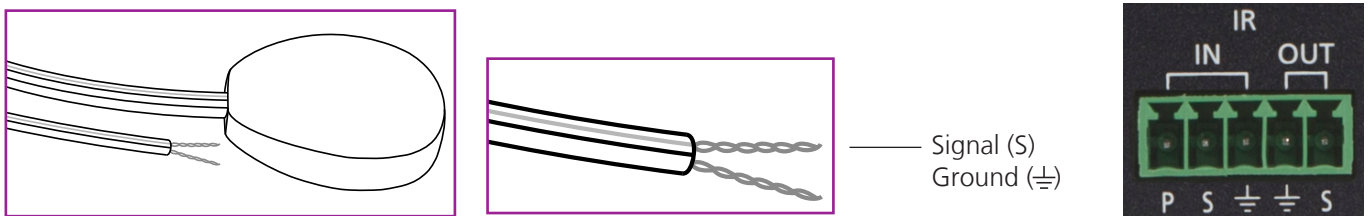

The included IR emitter has two wires: signal and ground. Signal will have a solid line and ground will be blank. The IR emitter will plug into the IR OUT ports.

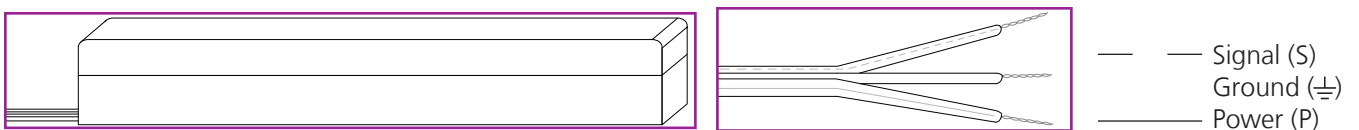

There are three wires on the IR receiver (sold separately): signal, ground, and power. Signal has a dotted line, ground will be blank, and power will have a solid line. The IR receiver will plug into the IR IN ports.

RS-232

Connection

RS-232 pin out will be determined by the RS-232 cable and will connect as Rx (receiver), Tx (transmitter), and \perp (ground). (See picture 1)

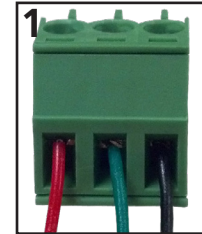
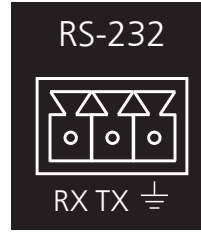

Wire color will differ by cable manufacturer.

RS-232 is often connected through a DB 9-pin to captive screw connector. The pins will have functions associated with them, some will be unassigned. Not all pins are used.

Note: Typical DB9 connectors use pin 2 for TX, pin 3 for RX, and pin 5 for ground. On some devices functions of pins 2 and 3 are reversed.

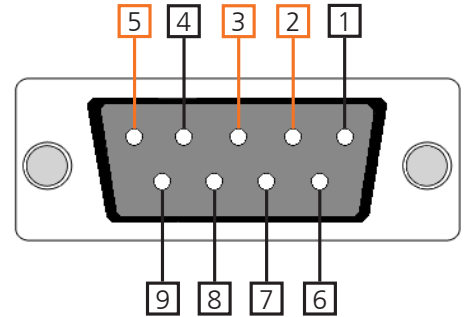

Set Up

To set up the RS-232 terminal (if not using 3rd party software) use the following steps:

1. Connect the CLSO-824 to a PC using a 3 pin to USB cable
2. Go to the Device Manager folder (see picture A)
3. Find the CLSO-824 COM port and right click with a mouse and select properties (see picture B)

Note: If unsure which COM port is the CLSO-824, unplug the cable and plug it back in. It will disappear and reappear on the COM port list.

4. Under the properties menu select the port settings tab and update the menu to the **CLSO-824 default settings of:** Bits per Second: 115200, Data Bits: 8, Parity: None, Stop Bits: 1 and Flow Control: None. (see picture C)

Set up is done and any terminal program may be used to control the CLSO-824 now.

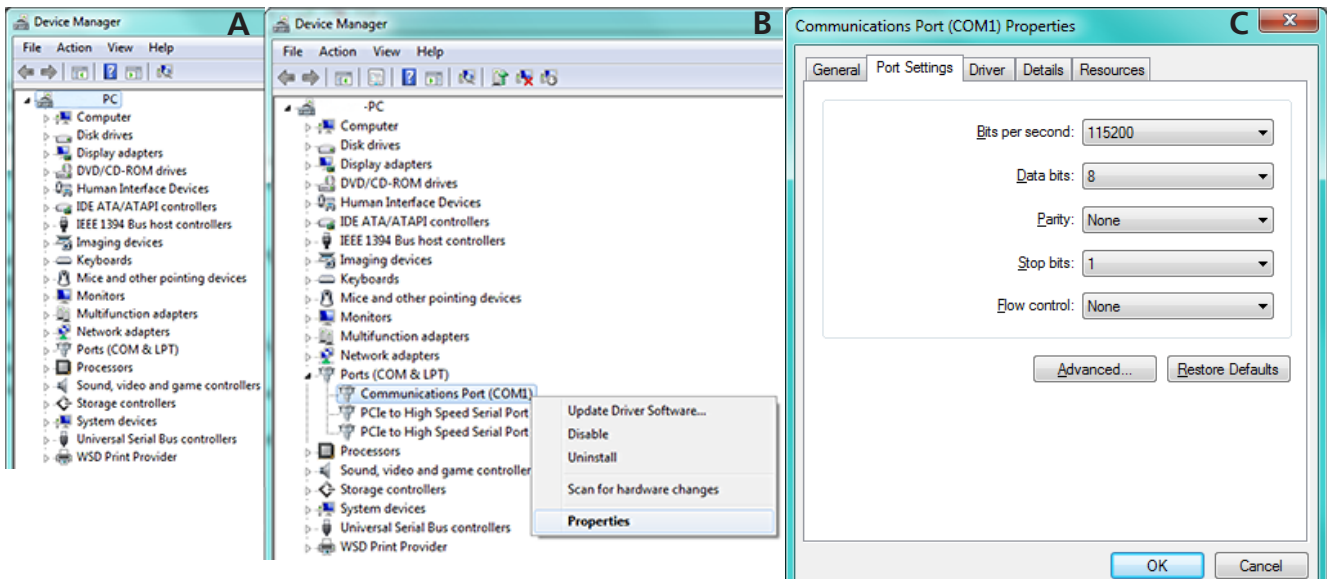

Commands

The command codes are case sensitive, do not change capitalization, spacing, or lettering.

Command	Feedback	Description
PWX e.g. PWSTA	PWX e.g. PWON	Turns switcher on, off, or display status X= ON, OFF, STA
System sta	Model: AT-UHD-CLSO-824 MAC Addr: XX-XX-XX-XX-XX-XX Address Type: DHCP IP: XXX.XXX.XX.XXX Netmask: 255.255.255.0 Gateway: XXX.XXX.XX.X HTTP Port: XX Telnet Port: XX Firmware: X.X.X On/Up Time <dd HH:mm:ss>: 04 01:09:32 Power Status: PWON	
HDVS sta	In 1: AT-HDVS-200TX IP:XXX.XXX.XX.XX MAC: XX-XX-XX-XX-XX-XX In 2: Null Out: AT-HDVS-200RX IP:XXX.XXX.XX.XX MAC: XX-XX-XX-XX-XX-XX	
VersionX	X.X.XX	Displays the current firmware version X = MCU, FPGA, OSD, or DSP
Type	AT-UHD-CLSO-824	Displays unit model number
Lock	Lock	Disables front panel buttons
Unlock	Unlock	Enables front panel buttons
All#	x1AVx1, x2AVx2	Resets all inputs to corresponding outputs
x1\$ y e.g. x2\$ off	x1\$ y e.g. x2\$ off	Turns on and off output video y=on, off, or sta e.g. Turns video off for output 2
x1All e.g. x5All	x1All e.g. x5All	Sets input to all outputs e.g. Set input 5 to all outputs
x1AVx2 e.g. x3AVx2	x1AVx2 e.g. x3AVx2	Switch input to output e.g. Set input 3 to output 2
x1AVx1,x2 e.g. x3AVx1,x2	x1AVx1,x2 e.g. x3AVx1,x2	Switch input to multiple outputs e.g. Swich input 3 to outputs 1 and 2
VGAMSet X e.g. VGAMSet comp	VGAMSet X e.g. VGAMSet comp	Sets the analog VGA port to accept VGA (vga) or Component (comp) e.g. Set the VGA port to accept component video
IRON	IRON	Turns the front panel IR receiver on
IROFF	IROFF	Turns the front panel IR receiver off
Statusx1 e.g. Statusx2	x1AVx3 e.g. x5AVx2	Shows the input currently connected to the output e.g. Show input status of ouput 2 - Input 5 is currently selected
Status	x4AVx1,x3AVx2	Displays the current input and output routes
SaveY e.g. Save2	SaveY e.g. Save2	Save the current input/output route to memory e.g. Save the current input/output route to memory 2
RecallY e.g. Recall4	RecallY e.g. Recall4	Recalls the saved input/output memory e.g. Recalls the input/output route from memory 4
ClearY e.g. Clear3	ClearY e.g. Clear3	Erases the input/output route from the selected memory number e.g. Removes the saved input/output route from memory 3
Menu[X]	Menu[X] e.g. MenuDown	Sets to control OSD interface, [X]: Sw/Up/Down/Left/Right/Info/Sel e.g. Select OSD option => MenuSel
Mreset	Mreset	Sets matrix settings back to factory settings
RS232zone[X][Y]	RS232zoneX[Y]	RS232zoneX[Y], X: 1-15 (see page 27). Y is the command sent to the HDBaseT port [Y] is the command string sent to the display device

When connecting or unconnecting HDBaseT devices to the CLSO (such as HDVS-200) the CLSO will send query commands to get device type information: RS232zoneX[WP_Display?]\$_{CR}CR

Command	Feedback	Description
EDIDMSetX default e.g. EDIDMSet3 default	EDIDMSetX default e.g. EDIDMSet2 default	Sets the input EDID to default X=Input e.g. Set input 2 EDID to default
EDIDMSetX saveY e.g. EDIDMSet7 save2	EDIDMSetX saveY e.g. EDIDMSet7 save2	Set input X EDID to the saved EDID memory (Y) e.g. Set input 7 to the EDID saved to memory 2
EDIDMSetX intZ e.g. EDIDMSet3 int7	EDIDMSetX intZ e.g. EDIDMSet3 int7	Set input EDID to the chosen internal EDID (Z) e.g. Set input 3 to the internal EDID 7
EDIDMSetX sta e.g. EDIDMSet6 sta	EDIDMSetX sta e.g. EDIDMSet6 default	Displays the current EDID (Y) of the selected input (X) e.g. Input 6 is set to default EDID
EDIDOutX memY e.g. EDIDOut2 mem1	EDIDOutX memY e.g. EDIDOut2 mem1	Copies EDID from an output (x) to a chosen memory location (y) e.g. Sets output 2 EDID to EDID memory 1

Internal EDIDs -

01 2160P60 Multi CH	02 2160P60 2CH	03 2160P30 Multi CH
04 2160P60 2CH	05 1920x1200 RGB 2CH	06 1080P DD
07 1080P Multi CH	08 1080P 2CH	09 1080P 3D DD
10 1080P 3D Multi CH	11 1080P 3D 2CH	12 1080P DVI
13 1280x800 RGB 2CH	14 1280x800 RGB DVI	15 1366x768 RGB 2CH
16 1024x768 RGB 2CH	17 720P DD	18 720P 2CH
19 800x600 RGB 2CH		

Command	Feedback	Description
PrefTimg8 Y e.g. PrefTimg8 3	PrefTimg8 Y e.g. PrefTimg8 3	Set the preferred timing of the VGA port Y=0-7 e.g. Set the VGA port to 1024x768
PrefTimg sta	PrefTimg8 Y	Displays the preferred timing for the VGA port
List X e.g. List Pref	List X e.g. Pref 0: Default Pref 1 : 1280x800 etc	Displays the preferred timings (Pref) and EDIDs (EDID) available
HDCPSetX Y e.g. HDCPSet5 Off	HDCPSetX Y e.g. HDCPSet5 Off	Sets HDCP reporting mode of the HDMI input port Y=on,off,sta e.g. Set input 5 to HDCP non-compliant

Preferred Timings -

00 Default	01 1920x1200	02 1920x1080
03 1280x800	04 1366x768	05 1024x768
06 1280x720	07 800x600	

Command	Feedback	Description
AUDx y e.g. AUD1 2	AUDx y e.g. AUD1 2	Set analog output (x) to use the audio of a specific port e.g. Set analog output 1 to follow the audio of HDMI/HDBaseT Out 2
Duckingx y e.g. Ducking2 on	Duckingx y e.g. Ducking2 on	Set the ducking on/off for output (x) y= on , off e.g. Set ducking on for output 2
Mixerx y e.g. Mixer1 3	Mixerx y e.g. Mixer1 3	Sets mixer source (y) for each analog output (x) e.g. Set analog output 1 to AUX1 and AUX2

Analog Output 1 -

1 AFV HDMI/HDBaseT Out 1	2 AFOV HDMI/HDBaseT Out 2
3 AUX1 MIC/Line Input 1	4 AUX2 MIC/Line Input 2

Analog Output 2 -

1 AFV HDMI/HDBaseT Out 2	2 AFOV HDMI/HDBaseT Out 1
3 AUX1 MIC/Line Input 1	4 AUX2 MIC/Line Input 2

Mixer sources -

0 None	1 AUX1	2 AUX2	3 AUX1 and AUX2
---------------	---------------	---------------	------------------------

Command	Feedback	Description
SetMonoX Y e.g. SetMono1 on	SetMonoX Y e.g. SetMono1 on	Sets analog audio output (X) to mono (on) or stereo (off) e.g. Set analog audio output 1 to mono
VOUTx + e.g. VOUT1 +	VOUTx yy e.g. VOUT1 yy	Increases output zone (x) volume by one e.g. Increase the volume of output 1
VOUTx - e.g. VOUT2 -	VOUTx yy e.g. VOUT2 yy	Decreases output zone (x) volume by one e.g. Decrease the volume of output 2
VOUTx yy e.g. VOUT1 08	VOUTx yy e.g. VOUT1 08	Sets output zone (x) volume to a specific level yy= -90 to 30 e.g. Sets the volume of output 1 to 8dB
VOUTx sta e.g. VOUT2 sta	VOUTx yy e.g. VOUT2 yy	Checks the level of output zone (x) volume e.g. Check the status of output zone 2
VINx + e.g. VIN3 +	VINx yy e.g. VIN3 yy	Increases the input zone (x) volume by one e.g. Increases the volume of input 3 by one
VINx - e.g. VIN5 -	VINx yy e.g. VIN5 yy	Decreases input zone (x) volume by one e.g. Decreases the volume of input 5 by one
VINx yy e.g. VIN2 -10	VINx yy e.g. VIN2 -10	Sets input zone (x) volume to a specific level e.g. Set input 2 volume to -10dB
VINx sta e.g. VIN6 sta	VINx yy e.g. VIN6 yy	Checks the level of input zone (x) volume e.g. Check the status of input zone 6
VINMuteX y e.g. VINMute3 on	VINMuteX y e.g. VINMute3 on	Mute or unmutes the specified input x= (1) Cat5 in1, (2) Cat5 in2, (3) Cat5 in3, (4) HDMI4, (5) HDMI5, (6) HDMI6, (7) HDMI7, (8) VGA (LINE3), (9) AUX1-source, (10) AUX2-source y = on (enable audio muting), off (disable audio muting), sta (displays the muting status) e.g. Mute input 3's volume
VOUTMuteX y e.g. VOUTMute1 off	VOUTMuteX y e.g. VOUTMute1 off	Mute (on) and unmute (off) the output (x) volume e.g. Unmute output 1's volume
VMicx + e.g. VMic1 +	VMicx yy e.g. VMic1 yy	Increases Mic input (x) level by one e.g. Increases the volume of MIC 1
VMicx - e.g. VMic2 -	VMicx yy e.g. VMic2 yy	Decreases Mic input (x) level by one e.g. Decreases the volume of Mic 2
VMicx yy e.g. VMic1 20	VMicx yy e.g. VMic1 20	Sets Mic input (x) volume to a specific level yy= -90 to 30 e.g. Set Mic input 1 to volume level 20
VMicx sta e.g. VMic2 sta	VMicx yy e.g. VMicx yy	Displays the current mic input (x) volume level e.g. Displays mic input 2 volume level
MICx y z e.g. MIC2 atime 20	MICx y z e.g. MIC2 atime 20	Sets Mic input (x) values (y) to specific levels (z) y= on, off, sta, atime (attack time), rtime (background release time), sens (microphone sensitivity level), reduce (background reduce level) e.g. Set the attack time of mic input 3 to 20
EQx y + e.g. EQ2 2 +	EQx y zz e.g. EQ2 2 zz	Increases the EQ band level (y) of the output (x) by one e.g. Increase output 3 EQ band level 500Hz by one
EQx y - e.g. EQ1 3 -	EQx y zz e.g. EQ1 3 zz	Decreases the EQ band level (y) of the output (x) by one e.g. Decrease output 1 band level 1.2 kHz by one
EQx y zz e.g. EQ2 4 10	EQx y zz e.g. EQ2 4 10	Set the EQ band level (y) of the output (x) to a specific level (zz) e.g. Set output 3 band level 3 kHz to a specific level
LipOutx + e.g. LipOut2 +	LipOutx yy e.g. LipOut2 yy	Increases lip sync time of output (x) by one e.g. Increase lip sync time of output 2 by one
LipOutx - e.g. LipOut1 -	LipOutx yy e.g. LipOut1 yy	Decreases lip sync time of output (x) by one e.g. Decrease lip sync time of output 1 by one
LipOutx yy e.g. LipOut2 10	LipOutx yy e.g. LipOut2 10	Set lip sync time of output (x) to a specific level (yy) e.g. Set output 2 lip sync to 10

EQ band -

1 <120Hz

2 500Hz

3 1.2 kHz

4 3 kHz

5 7.5 kHz

Baud Rate

Zone RS-232 port configuration must match the connected device on all parameters including baud rate, data-length, parity, and stop-bit. These parameters can easily be set using the WebGUI or following commands through RS-232 or TCP/IP.

The baud rate for the switcher is for switcher control and the transmitter/receiver baud rate is for control of the RS-232 device in zone. All commands from your control processor are at the settings for the switcher. The switcher will modify the baud rate and other settings to these set parameters by zone.

Note: Baud rate options 2400, 4800, 9600, 19200, 38400, 57600, 115200, or 230400

Command for Switcher Parameters

CSpara[baudrate,data-length,parity,stop-bit] (data, parity, and stop bit for switcher must be 8,0,1)

For example if you wish to change the baud rate of the switcher to 38400 the command would look like this: **CSpara[38400,8,0,1]**

Note: Using the command **CSpara** will display the current parameters of the switcher

Note: Default for the switcher is: Baud rate-115200bps, Data length-8bit, Parity-None, Stop Bit-1

RS-232 Command for the Output parameters

RS232para

The RS-232 status command will provide feedback for the current parameters for each transmitter/receiver.

Example: (See example of feedback below)

RS232para

Current RS232 parameter:

- Zone 1 :BaudRate 2400bps, DataBits 0, Parity None, StopBits 1.
- Zone 2 :BaudRate 115200bps, DataBits 0, Parity ODD, StopBits 1.
- Zone 3 :BaudRate 9600bps, DataBits 0, Parity None, StopBits 1.

Note: RS-232 zones 1-10 correspond with the RS-232 ports on the back of the switcher. There are additional zones for switcher and HDBaseT port pass through.

- Zone 11 = HDBaseT input port 1
- Zone 12 = HDBaseT input port 2
- Zone 13 = HDBaseT input port 3
- Zone 14 = HDBaseT output port 1
- Zone 15 = HDBaseT output port 2

IP Commands

Command	Feedback	Description
IPCFG	IP Addr : x.x.x.x Netmask : x.x.x.x Gateway : x.x.x.x IP Port: x.x.x	Displays IP address configuration
IPTimeout XX	IPTimeout XX (Ex. IPTimout120)	Determines amount of seconds of inactivity before TCP/IP disconnects. The default timeout is 45 seconds
IPQuit	IPQuit	Logs out of TCP/IP
IPAddUser	TCP/IP username & password list: - user password - user password - user password	Will display a list of users
IPAddUser X Y	TCP/IP user was added	Add a user for TCP/IP control. X=User Y=Password Ex. IPAddUser Atlona 1234 (User=Atlona 1234=Password)
IPDelUser X	TCP/IP user was deleted	Delete a user from TCP/IP X=User (Ex. IPDelUser Atlona)
IPDHCP sta	IPDHCP sta Ex. IPDHCP on	Displays the status of DHCP
IPDHCP on	IPDHCP on	Turns DHCP on
IPDHCP off	IPDHCP off	Turns DHCP off
IPStatic X Y Z	IPStatic address netmask gateway	Sets a static IP address Ex. IPStatic 192.168.1.1 255.255.255.0 192.168.1.200
IPPort X	IPPort X	Set the TCP/IP port (ex. IPPort 230)
IPLogin sta	IPLogin sta e.g. IPLogin on	Displays IPLogin status e.g. IPLogin is on
IPLogin on	IPLogin on	Enables IPLogin
IPLogin off	IPLogin off	Disables IPLogin
Broadcast sta	Broadcast sta	Displays broadcast mode status
Broadcast on	Broadcast on	Enables broadcast mode *Broadcast on is the default setting
Broadcast off	Broadcast off	Disables broadcast mode
CliMode x e.g. CliMode non-login	CliMode x e.g. CliMode non-login	Sets the control device's IP mode x = sta, login, non-login e.g. Sets the IP mode to non-login
CliUser x e.g. CliUser	CliUser x e.g. CliUser admin	Sets the IP username for login x = username, (blank) e.g. Display the IP username by leaving x blank
CliPass x e.g. CliPass AtlonA	CliPass x e.g. CliPass AtlonA	Sets the IP password for login x = password, (blank) e.g. Set the IP password to AtlonA
CliIPAddr x e.g. CliIPAddr sta	CliIPAddr x e.g. CliIPAddr 192.168.0.23	Sets the IP address of the controlled device x = ip, sta e.g. Display the IP address of the controlled device
CliPort x e.g. CliPort 24	CliPort x e.g. CliPort 24	Sets the IP port of the controlled device x = port, sta e.g. Set the IP port to 24

Each command must be terminated with a carriage return and line feed.

Feedback is terminated with a carriage return and line feed.

Note: If the command fails or is incorrect the feedback should be "Command FAILED"

Connection and Installation

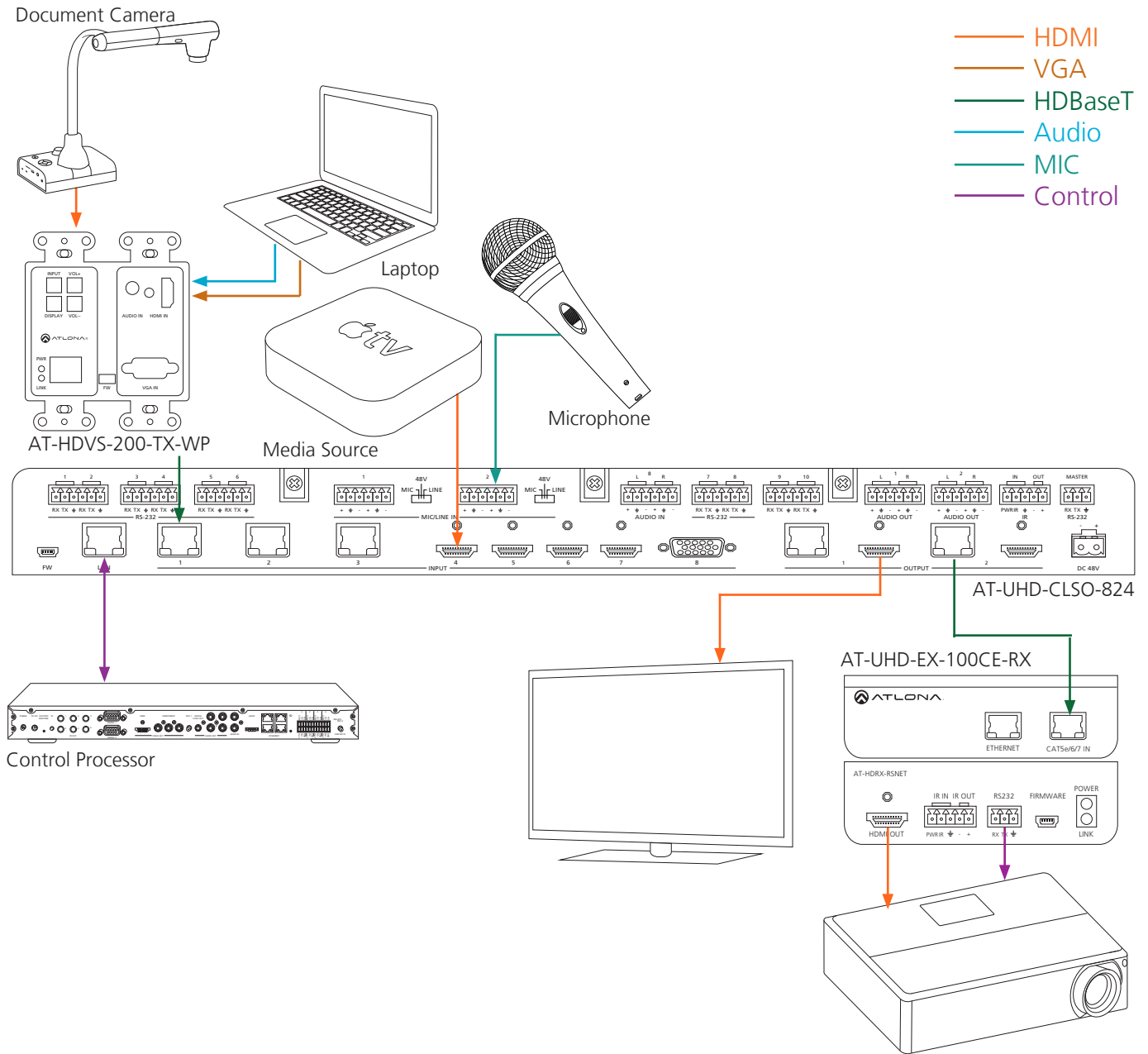

Control Drivers

Visit the **Control Drivers** tab at <http://www.atlona.com/product/AT-UHD-CLSO-824/> to download the control drivers for the CLSO-824.

CLSO-824 Update

Visit the **Firmware Update** tab at <http://www.atlona.com/product/AT-UHD-CLSO-824/> to download the current updates.

Note: Atlona is constantly improving and updating features and stability. It is recommended that you check to make sure you are on the most current firmware before installation, especially when using a control system.

Specifications

Video Resolutions

Video	4096x2160@24/25/30/60Hz*, 3840x2160@24/25/30Hz (UHD), 2048x1080p, 1080p@23.98/24/25/29.97/30/50/59.94/60Hz, 1080i@50/59.94/60Hz, 720p@50/59.94/60Hz, 576p, 576i, 480p, 480i	
VESA	2560x2048, 2560x1600, 2048x1536, 1920x1200, 1680x1050, 1600x1200, 1600x900, 1440x900, 1400x1050, 1366x768, 1360x768, 1280x1024, 1280x800, 1280x768, 1152x864, 1024x768, 800x600, 640x480	
Color Space	YUV, RGB	
Chroma Subsampling	4:4:4, 4:2:2, 4:2:0*	
Color depth	8-bit, 10-bit, 12-bit	

Audio

HDMI/HDBaseT OUT	PCM 2Ch, supports DTS and Dolby pass through	
Sample Rate	32kHz, 44.1kHz, 48kHz, 88.2kHz, 96kHz, 176.4kHz, 192kHz	
Bit rate	up to 24-bit	
Analog OUT	PCM 2Ch (de-embedded)	
Nominal Level:	+4 dBu, balanced audio	
Frequency Response:	20 - 20k Hz	
Maximum level:	+18 dBu	
Maximum input:	+24 dBu	
Equalization:	5 band EQ w/ -12/+15 dB with center freq. at 120, 500, 1.2k, 3k, 7.5k Hz	

Distance

CAT5e/6 @ 4K	up to 70 meters	up to 230 feet
CAT5e/6 @ 1080p	up to 100 meters	up to 328 feet
CAT6a/7 @ 4K	up to 100 meters	up to 328 feet
HDMI @ 4K	up to 5 meters	up to 15 feet
HDMI @ 1080p	up to 10 meters	up to 30 feet

Signal

Bandwidth	10.2 Gbps	
CEC	No	
HDCP	Switchable - Compliant / Non compliant	

Temperature

Operating	0°C to 50°C	32°F to 122°F
Storage	-20°C to 60°C	-4°F to 140°F
Humidity	20 to 90% non-condensing	

Power

Consumption	78.54W	
Idle Consumption	3.52W	
Supply	Input: 100~240 VAC 50/60Hz Output: 48 VDC 3.125A	

Dimension

H x W x D	44 x 433.8 x 255 (mm)	1.73 x 17.08 x 10.04 (inch)
w/feet	55.15 x 433.8 x 255 (mm)	2.17 x 17.08 x 10.04 (inch)
Rack Unit	1U	

Weight

Device	3.49 kg	7.69 lbs
--------	---------	----------

Certification

Power Supply	CE, FCC, cULus, RoHS, CCC, RCM	
Product	CE, FCC	

Safety Information

Safeguards



To reduce the risk of electric shock, do not expose this product to rain or moisture



Do not modify the wall plug. Doing so will void the warranty and safety features.



If the wall plug does not fit into your local power socket, hire an electrician to replace your obsolete socket.



This equipment should be installed near the socket outlet and the device should be easily accessible in the case it requires disconnection.

Precautions

FCC regulations state that any unauthorized changes or modifications to this equipment, not expressly approved by the manufacturer, could void the user's authority to operate this equipment.

Operate this product using only the included external power supply. Use of other power supplies could impair performance, damage the product, or cause fires.

In the event of an electrostatic discharge this device may automatically turn off. If this occurs, unplug the device and plug it back in.

Protect and route power cords so they will not be stepped on or pinched by anything placed on or against them. Be especially careful of plug-ins or cord exit points from this product.

Avoid excessive humidity, sudden temperature changes or temperature extremes.

Keep this product away from wet locations such as bathtubs, sinks, laundries, wet basements, fish tanks, and swimming pools.

Use only accessories recommended by Atlona to avoid fire, shock, or other hazards.

Unplug the product before cleaning. Use a damp cloth for cleaning and not cleaning fluid or aerosols. Such products could enter the unit and cause damage, fire, or electric shock. Some substances may also mar the finish of the product.

Never open, remove unit panels, or make any adjustments not described in this manual.

Attempting to do so could expose you to dangerous electrical shock or other hazards. It may also cause damage to your product. Opening the product will void the warranty.

Do not attempt to service the unit. Disconnect the product and contact your authorized Atlona reseller or contact Atlona directly.

Atlona, Inc. (“Atlona”) Limited Product Warranty Policy

Coverage

Atlona warrants its products will substantially perform to their published specifications and will be free from defects in materials and workmanship under normal use, conditions and service.

Under its Limited Product Warranty, Atlona, at its sole discretion, will either:

- A) repair or facilitate the repair of defective products within a reasonable period of time, restore products to their proper operating condition and return defective products free of any charge for necessary parts, labor and shipping
- OR**
- B) replace and return, free of charge, any defective products with direct replacement or with similar products deemed by Atlona to perform substantially the same function as the original products
- OR**
- C) refund the pro-rated value based on the remaining term of the warranty period, not to exceed MSRP, in cases where products are beyond repair and/or no direct or substantially similar replacement products exist.

Repair, replacement or refund of Atlona’s products is the purchaser’s exclusive remedy and Atlona’s liability does not extend to any other damages, incidental, consequential or otherwise.

This Limited Product Warranty extends to the original end-user purchaser of Atlona’s products and is non-transferrable to any subsequent purchaser(s) or owner(s) of these products.

Coverage Periods

Atlona’s Limited Product Warranty Period begins on the date of purchase by the end-purchaser. The date contained on the end-purchaser’s sales or delivery receipt is the proof purchase date.

Limited Product Warranty Terms – New Products

- 10 years from proof of purchase date for hardware/electronics products purchased on or after June 1, 2013
- 3 years from proof of purchase date for hardware/electronics products purchased before June 1, 2013
- Lifetime Limited Product Warranty for all cable products

Limited Product Warranty Terms – Refurbished (B-Stock) Products and Discontinued Products

- 3 years from proof of purchase date for all Refurbished (B-Stock) and Discontinued hardware and electronic products purchased on or after June 1, 2013.

Remedy

Atlona recommends that end-purchasers contact their authorized Atlona dealer or reseller from whom they purchased their products. Atlona can also be contacted directly. Visit www.atlona.com for Atlona’s contact information and hours of operation. Atlona requires that a dated sales or delivery receipt from an authorized dealer, reseller or end-purchaser is provided before Atlona extends its warranty services. Additionally, a return merchandise authorization (RMA) and/or case number, is required to be obtained from Atlona in advance of returns.

Atlona requires that products returned are properly packed, preferably in the original carton, for shipping. Cartons not bearing a return authorization or case number will be refused. Atlona, at its sole discretion, reserves the right to reject any products received without advanced authorization. Authorizations can be requested by calling 1-877-536-3976 (US toll free) or 1-408- 962-0515 (US/international) or via Atlona’s website at www.atlona.com.

Exclusions

This Limited Product Warranty excludes:

- Damage, deterioration or malfunction caused by any alteration, modification, improper use, neglect, improper packing or shipping (such claims must be presented to the carrier), lightning, power surges, or other acts of nature.
- Damage, deterioration or malfunction resulting from the installation or removal of this product from any installation, any unauthorized tampering with this product, any repairs attempted by anyone unauthorized by Atlona to make such repairs, or any other cause which does not relate directly to a defect in materials and/or workmanship of this product.
- Equipment enclosures, cables, power supplies, batteries, LCD displays, and any accessories used in conjunction with the product(s).
- Products purchased from unauthorized distributors, dealers, resellers, auction websites and similar unauthorized channels of distribution.

Disclaimers

This Limited Product Warranty does not imply that the electronic components contained within Atlona's products will not become obsolete nor does it imply Atlona products or their electronic components will remain compatible with any other current product, technology or any future products or technologies in which Atlona's products may be used in conjunction with. Atlona, at its sole discretion, reserves the right not to extend its warranty offering in instances arising outside its normal course of business including, but not limited to, damage inflicted to its products from acts of god.

Limitation on Liability

The maximum liability of Atlona under this limited product warranty shall not exceed the original Atlona MSRP for its products. To the maximum extent permitted by law, Atlona is not responsible for the direct, special, incidental or consequential damages resulting from any breach of warranty or condition, or under any other legal theory. Some countries, districts or states do not allow the exclusion or limitation of relief, special, incidental, consequential or indirect damages, or the limitation of liability to specified amounts, so the above limitations or exclusions may not apply to you.

Exclusive Remedy

To the maximum extent permitted by law, this limited product warranty and the remedies set forth above are exclusive and in lieu of all other warranties, remedies and conditions, whether oral or written, express or implied. To the maximum extent permitted by law, Atlona specifically disclaims all implied warranties, including, without limitation, warranties of merchantability and fitness for a particular purpose. If Atlona cannot lawfully disclaim or exclude implied warranties under applicable law, then all implied warranties covering its products including warranties of merchantability and fitness for a particular purpose, shall provide to its products under applicable law. If any product to which this limited warranty applies is a "Consumer Product" under the Magnuson-Moss Warranty Act (15 U.S.C.A. §2301, ET SEQ.) or other applicable law, the foregoing disclaimer of implied warranties shall not apply, and all implied warranties on its products, including warranties of merchantability and fitness for the particular purpose, shall apply as provided under applicable law.

Other Conditions

Atlona's Limited Product Warranty offering gives legal rights, and other rights may apply and vary from country to country or state to state. This limited warranty is void if (i) the label bearing the serial number of products have been removed or defaced, (ii) products are not purchased from an authorized Atlona dealer or reseller. A comprehensive list of Atlona's authorized distributors, dealers and resellers can be found at www.atlona.com.

Atlona, Inc Product Registration

Thank you for purchasing this Atlona product. - We hope you enjoy it and will take an extra few moments to register your new purchase.

Registration creates an ownership record if your product is lost or stolen and helps ensure you'll receive notification of performance issues and firmware updates.

At Atlona we respect and protect your privacy, assuring you that your registration information is completely secure. Atlona product registration is completely voluntary and failure to register will not diminish your limited warranty rights.

To register go to: <http://www.atlona.com/registration>