



OFFICE OF STATEWIDE HEALTH PLANNING AND DEVELOPMENT
FACILITIES DEVELOPMENT DIVISION

APPLICATION FOR OSHPD PREAPPROVAL OF
MANUFACTURER'S CERTIFICATION (OPM)

OFFICE USE ONLY

APPLICATION #: OPM-0255-13

OSHPD Preapproval of Manufacturer's Certification (OPM)

Type: [X] New [ ] Renewal [ ] Update to Pre-CBC 2013 OPA Number:

Manufacturer Information

Manufacturer: APC by Schneider-Electric

Manufacturer's Technical Representative: Greg Ivey

Mailing Address: 801 Corporate Centre Drive

Telephone: 636-300-2300 Email: greg.ivey@schneider-electric.com

Product Information

Product Name: Netshelter SX

Product Type: Network Equipment Cabinet OPM-0255-13

Product Model Number: Netshelter SX Cabinet Series (AR3abcXXXX)

General Description: Data center network equipment cabinet. See OPM drawing sheet SKIa for specific models included in this OPM.

DATE: 02/27/2017

Applicant Information

Applicant Company Name: APC by Schneider-Electric

Contact Person: Greg Ivey

Mailing Address: 801 Corporate Centre Drive

Telephone: 636-300-2300 Email: greg.ivey@schneider-electric.com

I hereby agree to reimburse the Office of Statewide Health Planning and Development review fees in accordance with the California Administrative Code, 2013.

Signature of Applicant: [Handwritten Signature]

Date: 8-5-15

Title: Engineering Manager - Rack Systems

Company Name: Schneider-Electric

"Access to Safe, Quality Healthcare Environments that Meet California's Diverse and Dynamic Needs"





**OFFICE OF STATEWIDE HEALTH PLANNING AND DEVELOPMENT  
FACILITIES DEVELOPMENT DIVISION**

**Registered Design Professional Preparing Engineering Recommendations**

Company Name: RMJ

Name: Jayson E. Haines California License Number: 4801

Mailing Address: 241 Joaquin Avenue, San Leandro, CA 94577

Telephone: 510-991-0977 Email: jhaines@rmjse.com

**OSHPD Special Seismic Certification Preapproval (OSP)**

- Special Seismic Certification is preapproved under OSP-  
(Separate application for OSP is required)
- Special Seismic Certification is not preapproved

**Certification Method(s)**

- Testing in accordance with:  ICC-ES AC156  FM 1950-10
- Other\* (Please Specify): \_\_\_\_\_

\*Use of criteria other than those adopted by the California Building Standards Code, 2013 (CBSC 2013) for component supports and attachments are not permitted. For distribution system, interior partition wall, and suspended ceiling seismic bracings, test criteria other than those adopted in the CBSC 2013 may be used when approved by OSHPD prior to testing.

- Analysis
- Experience Data
- Combination of Testing, Analysis, and/or Experience Data (Please Specify): \_\_\_\_\_

**List of Attachments Supporting the Manufacturer's Certification**

- Test Report  Drawings  Calculations  Manufacturer's Catalog
- Other(s) (Please Specify): \_\_\_\_\_

**OFFICE USE ONLY – OSHPD APPROVAL VALID FOR CBC 2013 ONLY**

Signature:  Date: 02-27-2017

Print Name: Jeffrey Kikumoto

Title: SSE

Condition of Approval (if applicable): \_\_\_\_\_

"Access to Safe, Quality Healthcare Environments that Meet California's Diverse and Dynamic Needs"



Robinson  
Meier  
Jully & Associates

Principals  
*Peter Robinson, S.E.*  
*Jayson E. Haines, S.E.*

# Schneider Electric™

## NetShelter SX

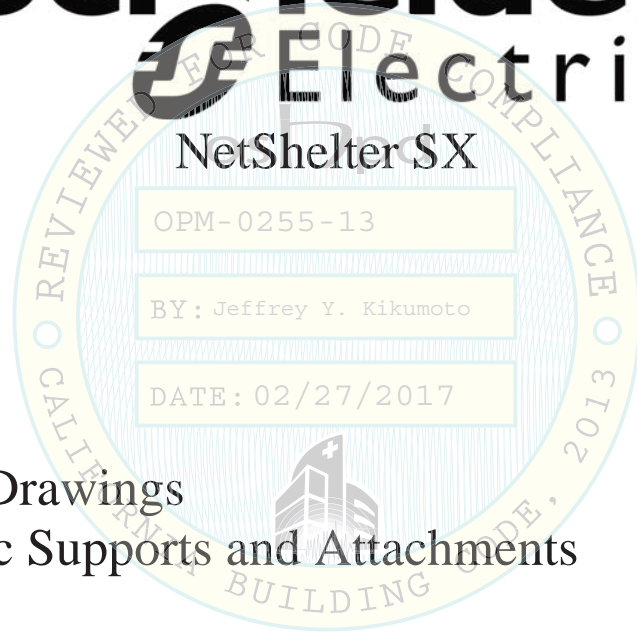

## Structural Drawings For Seismic Supports and Attachments

Prepared for:

Schneider Electric  
February 14, 2017  
RMJ Job No. 15262



241 Joaquin Avenue  
San Leandro, CA 94577  
(510) 991-0977

# GENERAL NOTES

DESIGN

1. This OSHPD pre-approval of Manufacturer's Certification (OPM) based on the 2013 CBC. The demand (Design) forces for use with this OPM shall be based on the 2013 CBC.

1. This Document may only be used with the express written consent of the manufacturer listed below for the specific project site and installation location. This document is invalid without such consent.

Design Criteria:

Importance Factor .....1.5

Maximum Value of  $S_{DS}=2.0$ ,  $a_p=1.0$ ,  $R_p=2.5$ ,  $\Omega_0=2.5$  (As req'd for anchorage to concrete),  $z/h=0.0$  (Concrete slab on grade),  $z/h \leq 0.5$  for raised floor in lower half of building height.

Forces per ASCE 7-10 section 13.3.1, Equations 13.3-1, 13.3-2 & 13.3-3.

\*Note: For Site Specific  $S_{DS}$ , SEOR shall determine appropriate value to be utilized.\*

Dimensions: Refer to rough concrete surfaces, or top of slab, unless otherwise indicated.

Fasteners Expansion Anchors:

Anchor Diameter	Concrete Type	Min. $f'_c$ (psi)	Anchor Type	ICC Report No.	$h_{ef}$ Min. Embed.	Min. Spacing	Min. Edge Dist.	Min. Conc. Thickness	Torque Test	Direct Tension
1/2"	Normal Weight	3,000	Hilti Kwik Bolt TZ CS	ESR-1917	2"	6"	24"	4"	40 FT-LB	1605 lb

This pre-approval allows for up to a maximum of two adjacent concrete slab edges, 24" away minimum. See detail below for additional minimum allowable concrete edge distances. Testing of expansion anchors per 2013 CBC, 1913A.7: After a minimum of 24 hours have elapsed since installation, bolt testing shall be done in the presence of the special inspector and a report of the test results shall be submitted to SEOR and building code enforcement agency. Testing may be, direct pull tension test or torque test of at least 50% of the anchors.

DATE: 02/27/2017

Test Loads:

Drawing package is in accordance with the 2013 California Building Code.

The details are applicable to locations in California where  $S_{DS} \leq 2.0$  and  $z/h \leq 0.5$ . For site specific  $S_{DS}$ , SEOR shall determine appropriate value to be utilized.

Anchorage forces shown on the drawings are factored loads that are associated with strength design.

This pre-approval only applies to the supports & attachments of the cabinet unit to the structure.



 Robinson Meier Juilly & Associates 241 Joaquin Avenue San Leandro CA 94577 510.991.0977	SCHNEIDER ELECTRIC NETSHELTER SX	Job No. 15262
	OSHPD CABINET SUPPORTS AND ATTACHMENTS	Sheet No. (SK1)
	Signed by JEH	Date 11/14/2016

# RACK MATRIX (Netshelter SX Series)

Model #	WidthXDepth	Height	U ref. per EIA-310	Weight	Anchor forces (lbs)			
					$z/h=0.0$	$z/h=0.5$	$z/h=0.0$	$z/h=0.5$
AR3abcXXXX	600x1070	1198	24	196	1220	440	625	660
		1991	42	275	1220	440	625	660
		2124	45	300	1220	440	625	660
		2258	48	327	1220	440	625	660
		2347	50	196	1220	440	625	660
		2436	52	367	1220	440	625	660
	600x1200	2525	54	389	1220	440	625	660
		1198	24	212	1220	440	625	660
		1991	42	295	1220	440	625	660
		2124	45	322	1220	440	625	660
		2258	48	350	1220	440	625	660
		2347	50	372	1220	440	625	660
	750x1070	2436	52	394	1220	440	625	660
		2525	54	417	1220	440	625	660
		1198	24	235	1220	440	625	660
		1991	42	335	1220	440	625	660
		2124	45	365	1220	440	625	660
		2258	48	398	1220	440	625	660
	750x1200	2347	50	422	1220	440	625	660
		2436	52	447	1220	440	625	660
		2525	54	474	1220	440	625	660
		1198	24	251	1220	440	625	660
		1991	42	355	1220	440	625	660
		2124	45	387	1220	440	625	660
	800x1070	2258	48	422	1220	440	625	660
		2347	50	447	1220	440	625	660
		2436	52	474	1220	440	625	660
		2525	54	502	1220	440	625	660
		1198	24	249	1220	440	625	660
		1991	42	355	1220	440	625	660
	800x1200	2124	45	387	1220	440	625	660
		2258	48	409	1220	440	625	660
		2347	50	446	1220	440	625	660
		2436	52	472	1220	440	625	660
		2525	54	501	1220	440	625	660
		2525	54	531	1220	440	625	660

Maximum anchor value for either a single unit or set of ganged units. 600 mm units must ganged at ground floor; Single 600mm units not allowed at ground floor.

AR3abcXXXX Series cabinets defined by:

- a denotes depth:  
1 or 2 42.1" (1070 mm) deep  
3 47.2" (1200 mm) deep
- b denotes width:  
0 or 1 23.6" (600mm) wide  
4 or 5 29.5" (750 mm) wide  
8 31.5" (800 mm) wide
- c denotes height:  
0, 1 or 2 78.4" (1991 mm) high for 42U  
4 47.2" (1198 mm) high for 24U  
5 83.6" (2124 mm) high for 45U  
6 92.4" (2347 mm) high for 50U  
7 88.9" (2258 mm) high for 48U  
8 95.9" (2436 mm) high for 52U  
9 99.4" (2525 mm) high for 54U

Note: U designations are per EIA-310  
EIA is Electronic Industries Association

SCHNEIDER  
CERTIFIES THIS DOCUMENT AS  
AN OUTLINE DRAWING.  
SIGNATURE: *[Signature]*  
PRINT NAME: *[Name]*  
TITLE: ME Manager Placks  
DATE: 11-11-16

U reference is depth of cabinet per Electronic Industries Alliance.

FOR PLAN REFERENCE, SEE SHEET SK4



<p>Robinson Meier Jully &amp; Associates</p> <p>241 Joaquin Avenue San Leandro CA 94577 510.991.0977</p>	<p>SCHNEIDER ELECTRIC NETSHELTER SX</p>	Job No. 15262
	<p>OSHPD CABINET SUPPORTS AND ATTACHMENTS</p>	Sheet No. <span style="border: 1px solid black; border-radius: 50%; padding: 2px;">SK1a</span>
	<p>Signed by JEH      Date 2/24/2017</p>	

RESPONSIBILITY OF STRUCTURAL ENGINEER OF RECORD

1. Verify that the concrete meets the requirements of the applicable ICC ESR.
2. Verify that the anchors are at an adequate distance from any slab opening or edges.
3. Verify that all new or existing anchors are at an adequate distance from the anchors shown in this pre-approval. The SEOR shall verify that there is no adverse interaction where other anchors are within 18" or  $6 h_{ef}$  from the unit's anchors.
4. Verify the adequacy of the structure to support the weight and forces shown in this pre-approval in addition to all other weights and forces that are imposed on it.
5. Provide any supplementary structure required for strength and stability.
6. Verify that the installation is in conformance with the 2013 CBC and with the notes and details shown in this pre-approval. Verify that the equipment's actual weight, center of gravity location, anchor locations, anchor details and the material and gage of the unit where attachments are made conform with the information shown in this pre-approval.
7. If content weight is less than 33 pcf, maximum live loads permitted shall be posted.

Acceptance Criteria for Expansion Anchors:

Direction Tension Test:

Anchor shall maintain and hold test load of minimum (15) seconds & shall exhibit no discernable movement during the tension test, e.g., as evidenced by loosening of the washer under the nut.

Torque Test:

The applicable torque must be achieved within the following limits: wedge type: 1/2 turn of the nut.

Acceptance Criteria for Bolts thru Concrete on Metal Deck:

- A. Bolts shall be torqued by  $\frac{3}{4}$  turn of the nut, after snug tight condition is achieved. Snug tight condition is defined as the tightness required to bring the connected plies into firm contact.
- B. Thru bolt holes size shall be 1/16" larger than bolt size for concrete.
- C. Thru bolts in concrete shall receive Special Inspection and Testing (Through bolts with steel to steel connection in tension do not require tension testing) in accordance with requirements for post-installed concrete anchors.

\*If any anchor fails testing, all anchors of the same type shall be tested, which are install by the same trade, not previously tested until twenty (20) consecutive anchors pass, then resume initial test frequency.

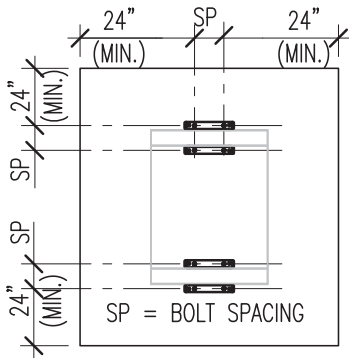

TYPICAL CONCRETE  
EDGE DETAIL

- Avoid damaging existing steel reinforcing in concrete slab when installing expansion anchors.
- Provide for full thread engagement of nut & washer.



 Robinson Meier Juilly & Associates 241 Joaquin Avenue San Leandro CA 94577 510.991.0977	SCHNEIDER ELECTRIC NETSHELTER SX	Job No. 15262
	OSHPD CABINET SUPPORTS AND ATTACHMENTS	Sheet No. (SK2)
	Signed by JEH	Date 11/14/2016

SEISMIC SUPPORT, ATTCHMENTS & ANCHORAGE

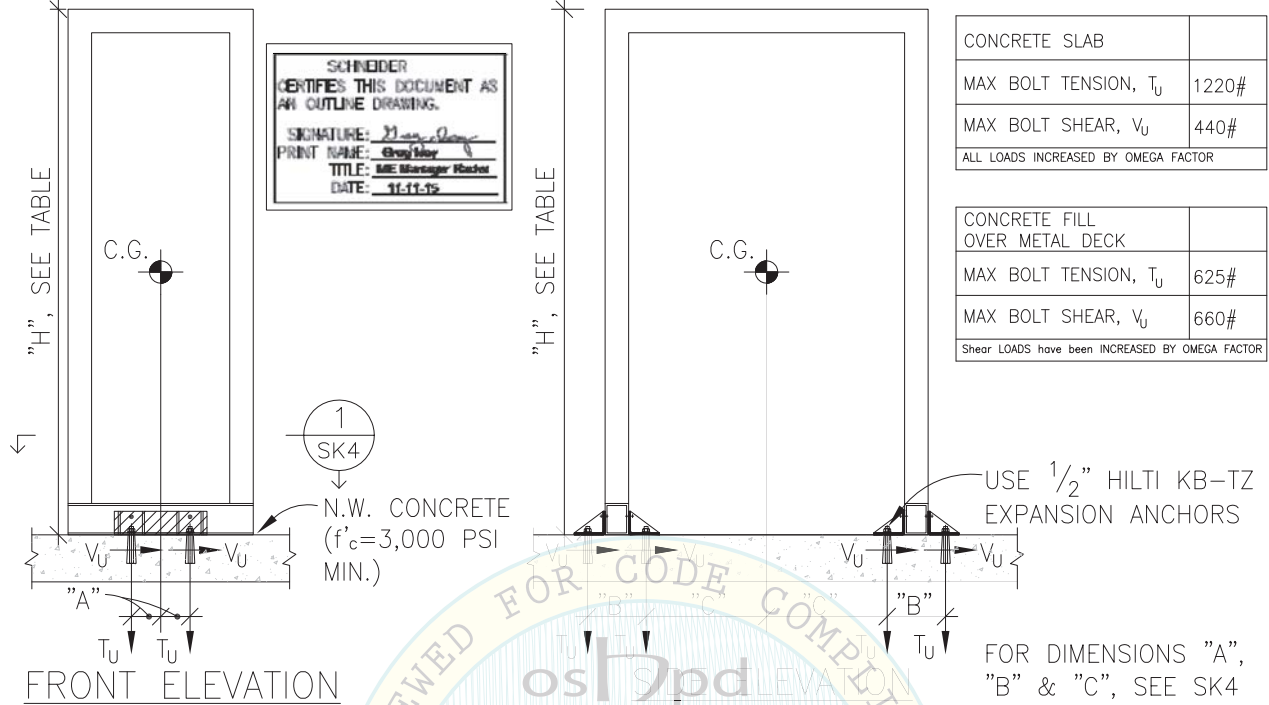

NOTES:

- DESIGN CENTER OF GRAVITY AT 1/2 THE HEIGHT OF THE UNIT. (NOTE: LOAD CABINET FROM BOTTOM FIRST)
- FORCES ARE DETERMINED PER 2013 CBC AND ITS REFERENCED STANDARDS AND ASCE 7-10 STRENGTH DESIGN. ( $S_{DS} \leq 2.0$  (HIGH SEISMIC) 1.0 (LOW SEISMIC),  $a_p = 1.0$ ,  $I_p = 1.5$ ,  $R_p = 2.5$ ,  $\Omega = 2.5$ ,  $Z_h = 0$  (GROUND LEVEL) &  $z/h \leq .5$  (50% OF BLDG. HT.)).
- SEE GENERAL NOTES FOR ALL OTHER CONDITIONS AND LIMITATIONS.
- NETSHELTER SX EXTERIOR CABINET UNIT COVER COMPOSED OF 14 ga COLD ROLLED STEEL 29.4 ksi.
- SIGN MUST BE POSTED INDICATING CABINET TOTAL WEIGHT LISTED IN THE TABLE 1.
- WEIGHTS LISTED IN "TABLE 1" APPLY TO ALL UNITS IRRESPECTIVE OF SIZE.
- ARCHITECT OR ENGINEER OF RECORD TO VERIFY THE SPECIFIC CONFIGURATION OF THE COMPONENTS WITHIN THE CABINET COMPLIES WITH C.G. PARAMETERS INDICATED IN NOTE #1.

MAXIMUM CABINET TOTAL WEIGHT (TABLE 1)

MODEL NUMBER	MAX TOTAL WEIGHT, GROUND FLOOR, SINGLE UNIT*	MAX WEIGHT, GROUND FLOOR, GANGED UNITS* (WEIGHT PER UNIT)**	MAX TOTAL WEIGHT, UPPER FLOOR, SINGLE UNIT	MAX WEIGHT, UPPER FLOOR, GANGED UNIT* (WEIGHT PER UNIT)**
DIRECT ON FLOOR	800 LBS.	1200 LBS.	N/A	1100 LBS.

\*MAX WEIGHT IS CABINET AND CONTENTS

\*\*THIS WEIGHT IS PER CABINET IN GANGED CONFIGURATION; NO MAXIMUM ON # OF GANGED UNITS

MAXIMUM CABINET WEIGHTS	
600 mm WIDTH	417#
750 mm WIDTH	502#
800 mm WIDTH	531#

TABLE APPLIES TO 1070 mm AND 1200 mm CABINETS

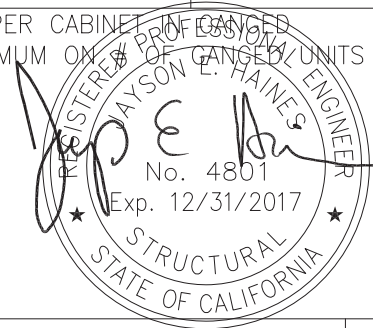

ALLOWABLE CONTNET WEIGHT IS DIFFERENCE BETWEEN CABINET WEIGHT AND MAX WEIGHT NOTED IN TABLE

 Robinson Meier Jullily & Associates 241 Joaquin Avenue San Leandro CA 94577 510.991.0977	SCHNEIDER ELECTRIC NETSHELTER SX	Job No. 15262
	OSHPD CABINET SUPPORTS AND ATTACHMENTS	Sheet No. SK3
	Signed by JEH Date 2/24/2017	

**NOTES:**

\*SEE Rack Matrix on sheet SK1a for all possible dimensions. Design based on AR3 series rack.  
 \*INTERNAL and EXTERNAL BRACKETS SHALL BE INSTALLED FOR OSHPD PROJECTS.

**CONDITION SCHEDULE**

CONDITION	SEE
CONCRETE SLAB	(SK6)

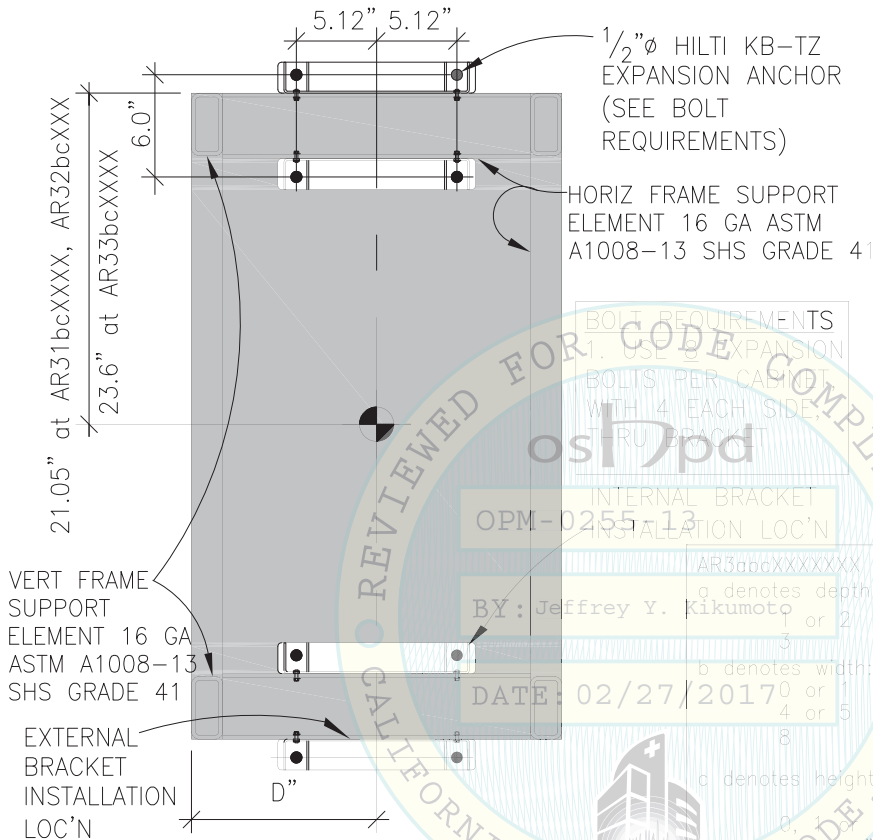

**SCHNEIDER**  
 CERTIFIES THIS DOCUMENT AS  
 AN OUTLINE DRAWING.  
 SIGNATURE: *Greg Ivey*  
 PRINT NAME: Greg Ivey  
 TITLE: ME Manager Racks  
 DATE: 11-11-15

BRACKET MATERIAL (0.1181" THK, ASTM A1008-13 SHS GRADE 41) w/ M8 (ISO 898-1 CLASS 10.9) BOLTS PROVIDED BY NETSHELTER.

**BOLT REQUIREMENTS**  
 1. USE 3 EXPANSION BOLTS PER CABINET WITH 4 EACH SIDE, 1 FOR BRACKET

**INTERNAL BRACKET INSTALLATION LOC'N**

AR3abcXXXXXXXXX - as follows

a denotes depth:  
 1 or 2 42.1" (1070 mm) deep  
 3 47.2" (1200 mm) deep

b denotes width:  
 0 or 1 23.6" (600 mm) wide  
 4 or 5 29.1" (750 mm) wide  
 8 (800 mm) wide

c denotes height: (U designations per EIA-310) (EIA is Electronic Industries Association)  
 0, 1, 2 78.4" (1991 mm) high for 42U rack  
 3 84.3" (2141 mm) high for 44U rack  
 4 87.2" (2215 mm) high for 46U rack  
 5 89.6" (2284 mm) high for 48U rack  
 6 92.4" (2357 mm) high for 50U rack  
 7 88.9" (2258 mm) high for 48U rack  
 8 95.9" (2436 mm) high for 52U rack  
 9 99.4" (2525 mm) high for 54U rack

DATE: 02/27/2017

BY: Jeffrey Y. Kikumoto

**AR3abc SERIES BOTTOM PLAN VIEW**  
**PLAN**  
 N.T.S. (1) SK4

MAX/MIN DIMENSIONS: (TABLE 2)

MODEL	"H" MAX (in.)	"D" MIN (in.)	MAX CABINET FRAME WEIGHT
AR3abcXX	99.4"	11.8"	531#

BASED ON ARa0cxxx and AR3a1cxxx SERIES  
 BASED ON AR3ab9xxx SERIES



<p>Robinson Meier Jullily &amp; Associates                  Structural Engineers                  241 Joaquin Avenue                  San Leandro CA 94577                  510.991.0977</p>	SCHNEIDER ELECTRIC NETSHELTER SX	Job No. 15262
	OSHPD CABINET SUPPORTS AND ATTACHMENTS	Sheet No. (SK4)
	Signed by JEH      Date 11/14/2016	



**NOTES:**

\*SEE Rack Matrix on sheet SK1a for all possible dimensions. Design based on AR3 series rack.  
 \*INTERNAL and EXTERNAL BRACKETS SHALL BE INSTALLED FOR OSHPD PROJECTS.

**CONDITION SCHEDULE**

CONDITION	SEE
CONCRETE SLAB	(SK6)
CONCRETE FILL OVER METAL DECK	(SK7)

**INSTALLATION FOR THE FOLLOWING CONDITIONS:**

1. SEE BOLT REQUIREMENTS ON SK4 FOR ANCHORAGE REQUIREMENTS.

CONCRETE SLAB		CONCRETE FILL OVER METAL DECK	
MAX BOLT TENSION, $T_u$	1220#	MAX BOLT TENSION, $T_u$	625#
MAX BOLT SHEAR, $V_u$	440#	MAX BOLT SHEAR, $V_u$	660#
ALL LOADS have been INCREASED BY OMEGA FACTOR		Shear LOADS have been INCREASED BY OMEGA FACTOR	

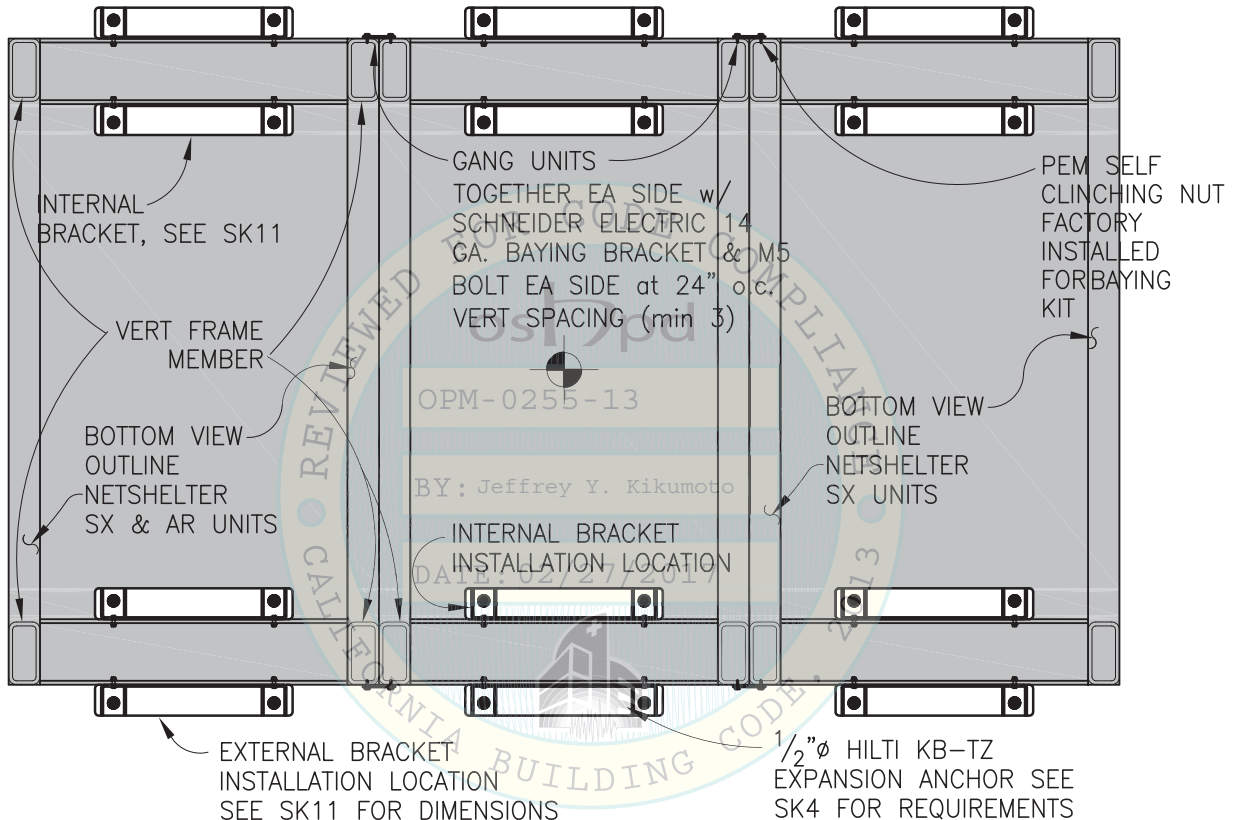

**GANG UNIT BOTTOM PLAN VIEW (3 UNITS OR MORE GANGED TOGETHER)**  
 NO MAXIMUM # OF UNITS

SCHNEIDER  
 CERTIFIES THIS DOCUMENT AS  
 AN OUTLINE DRAWING.

SIGNATURE: *Greg Ivey*  
 PRINT NAME: Greg Ivey  
 TITLE: ME Manager Racks  
 DATE: 11-11-15

**PLAN**  
 N.T.S.

1  
 SK5



<p>Robinson Meier Juilly &amp; Associates</p> <p>241 Joaquin Avenue San Leandro CA 94577 510.991.0977</p>	<p>SCHNEIDER ELECTRIC NETSHELTER SX</p>	<p>Job No. 15262</p>
	<p>OSHPD CABINET SUPPORTS AND ATTACHMENTS</p>	<p>Sheet No. (SK5)</p>
	<p>Signed by JEH Date 2/24/2017</p>	

SCHNEIDER  
 CERTIFIES THIS DOCUMENT AS  
 AN OUTLINE DRAWING.  
 SIGNATURE: *Greg Meier*  
 PRINT NAME: Greg Meier  
 TITLE: ME Manager/Trucker  
 DATE: 11-11-19

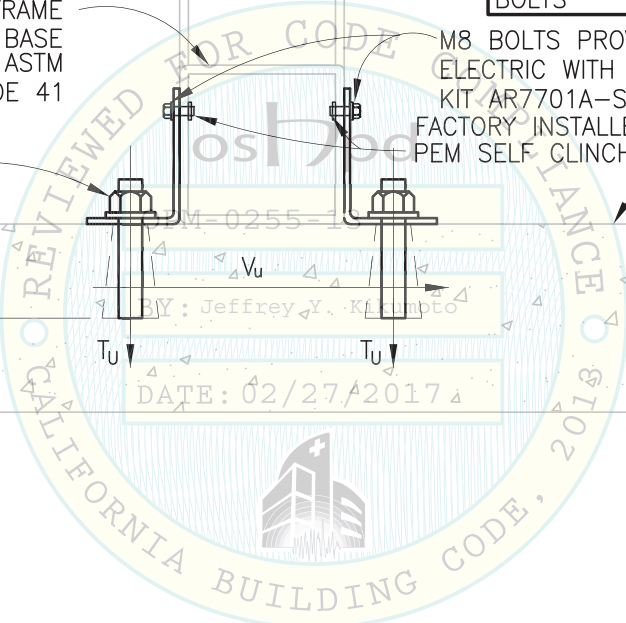
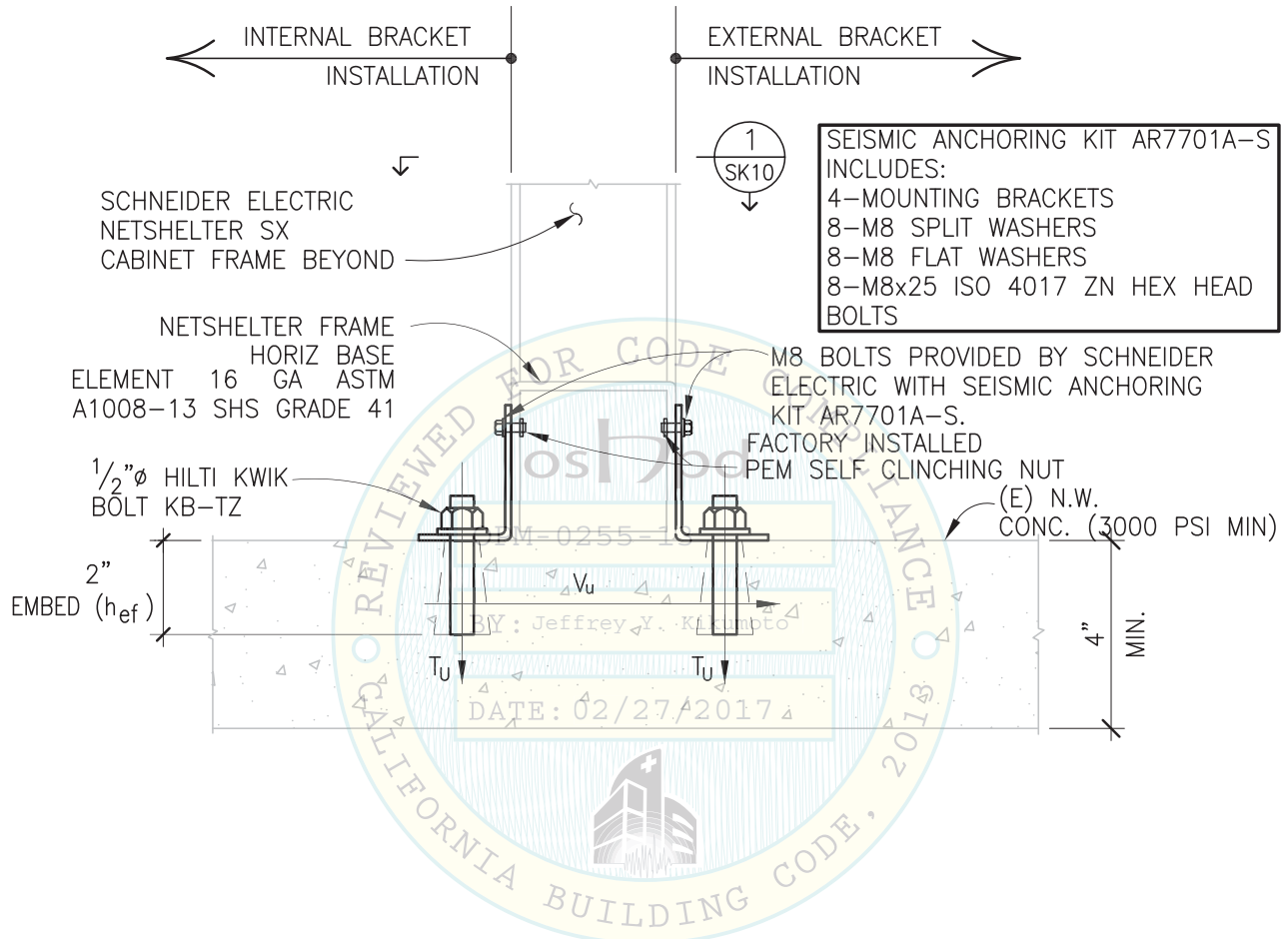

**CONCRETE SLAB  
 INSTALLATION**

**DETAIL**

3" = 1'-0"

1  
 SK6



 Robinson Meier Juilly & Associates 241 Joaquin Avenue San Leandro CA 94577 510.991.0977	SCHNEIDER ELECTRIC NETSHELTER SX	Job No. 15262
	OSHPD CABINET SUPPORTS AND ATTACHMENTS	Sheet No. SK6
	Signed by JEH      Date 2/24/2017	

**SCHNEIDER NETSHELTER SX UNIT CABINET NOTES:**

1. CABINET COVER GAGE THICKNESS SHALL NOT BE LESS THAN 16 ga.
2. BASE MATERIAL SHALL BE COLD ROLLED STEEL 29.4 ksi.
3. THE STRUT(S) AND ITS ATTACHMENTS ARE DESIGNED TO RESIST A LOAD NOT LESS THAN  $V_u$  STRUT IN COMBINATION WITH ALL OTHER LOADS THAT MAY BE PRESENT, WHERE  $V_u$  STRUT =  $0.7V_u \times$  (NO. OF ANCHORS ENGAGED BY STRUT), MIN.

SCHNEIDER  
 CERTIFIES THIS DOCUMENT AS  
 AN OUTLINE DRAWING.  
 SIGNATURE: *Greg Frey*  
 PRINT NAME: Greg Frey  
 TITLE: ME Manager Packs  
 DATE: 11-11-15

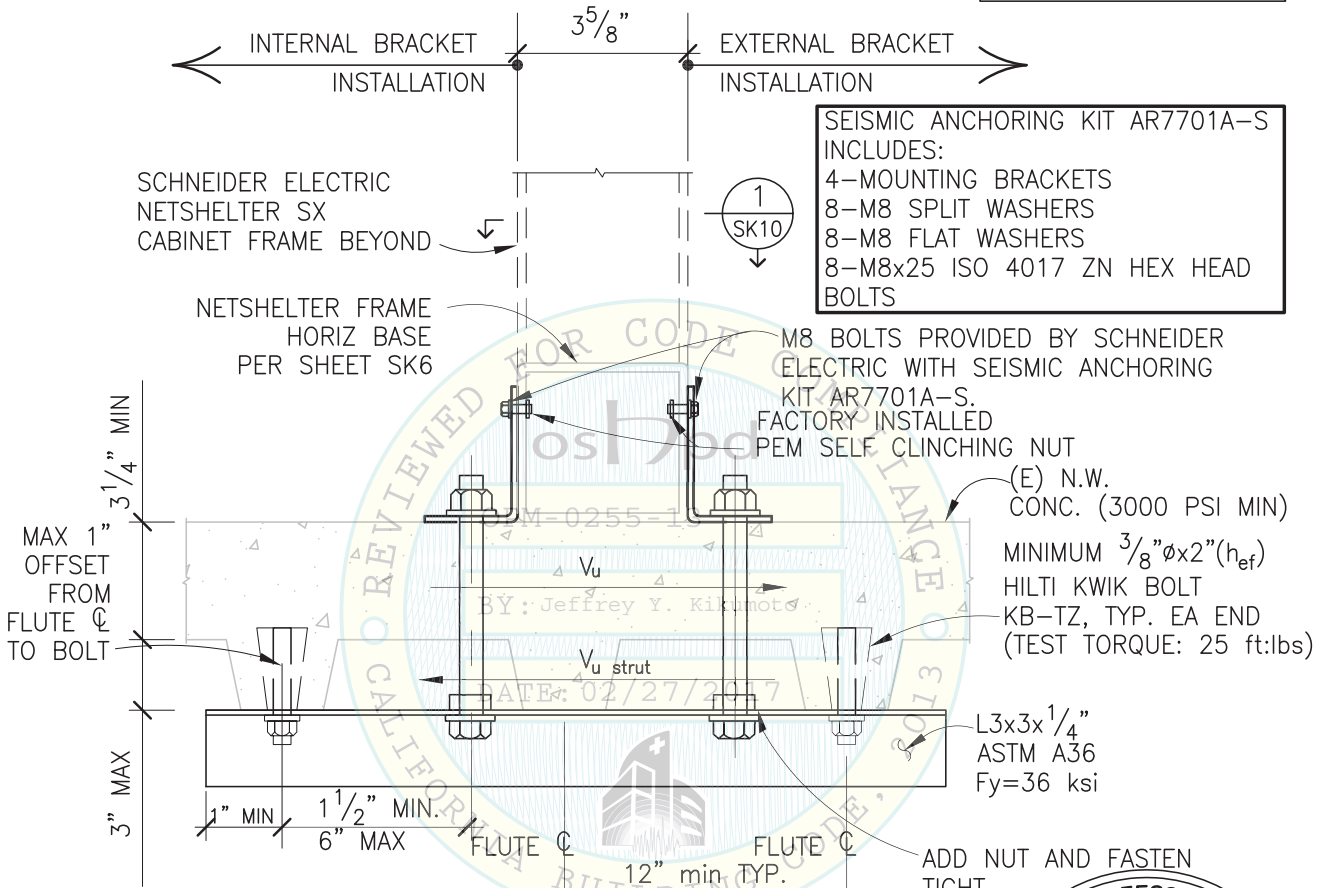

PROVIDE HEX NUT at TOP & BOTTOM OF HORIZ. ANGLE LEG, TYP. AT CONDITIONS WHERE WHERE THE NUT CANNOT BE PROVIDED AT THE TOP OF HORIZ. LEG (WHEN BOLT GOES THRU LOWER FLUTE) PROVIDE TAPPED HOLE THRU HORIZ LEG.

**CONCRETE FILL OVER METAL DECK INSTALLATION**

**DETAIL 1**  
 3" = 1'-0"      SK7



<p>Robinson Meier Juilly &amp; Associates                  241 Joaquin Avenue                  San Leandro CA 94577                  510.991.0977</p>	SCHNEIDER ELECTRIC NETSHELTER SX	Job No. 15262
	OSHPD CABINET SUPPORTS AND ATTACHMENTS	Sheet No. SK7
	Signed by JEH      Date 2/24/2017	

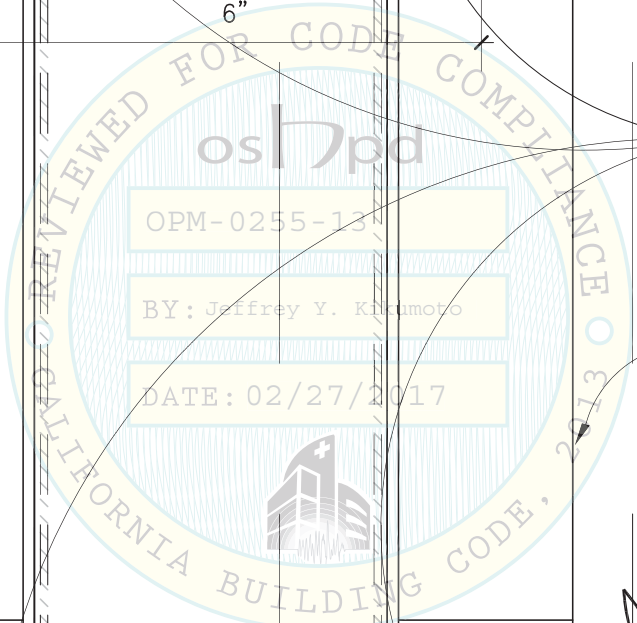
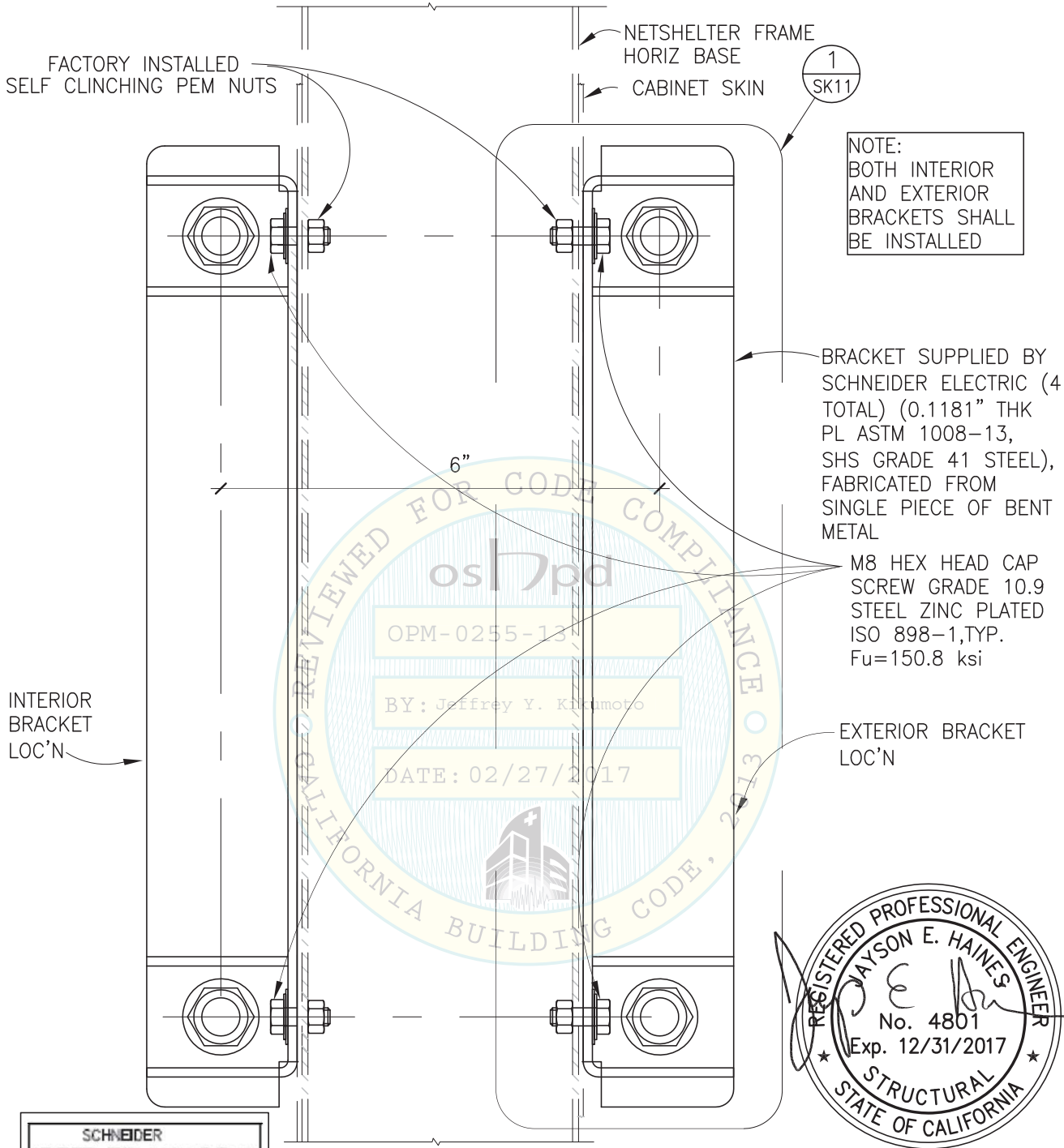

SCHNEIDER  
 CERTIFIES THIS DOCUMENT AS  
 AN OUTLINE DRAWING.  
 SIGNATURE: *[Signature]*  
 PRINT NAME: Greg Frey  
 TITLE: ME Manager Pacific  
 DATE: 11-11-15

**DETAIL** 1  
 N.T.S. SK10

<p>Robinson Meier Juilly &amp; Associates</p> <p>241 Joaquin Avenue San Leandro CA 94577 510.991.0977</p>	<p>SCHNEIDER ELECTRIC NETSHELTER SX</p>	<p>Job No. 15262</p>
	<p>OSHPD CABINET SUPPORTS AND ATTACHMENTS</p>	<p>Sheet No. <span style="border: 1px solid black; border-radius: 50%; padding: 2px;">SK10</span></p>
	<p>Signed by JEH      Date 11/14/2016</p>	

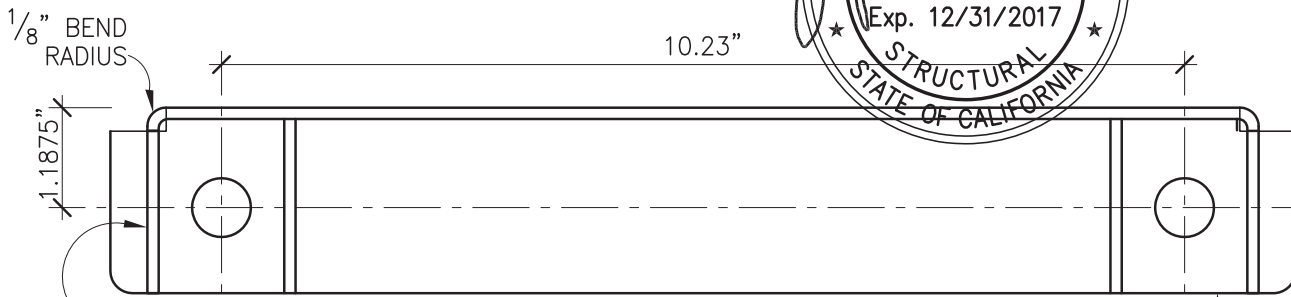

STIFFENER GUSSET  
BENT FROM VERTICAL LEG

### SEISMIC BRACKET PLAN

BRACKET SUPPLIED BY SCHNEIDER  
ELECTRIC (4 TOTAL) (0.1181" THK PL  
ASTM 1008-13, SHS GRADE 41 STEEL)

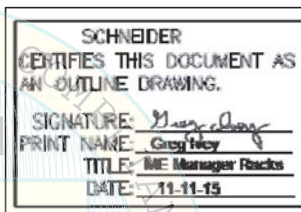
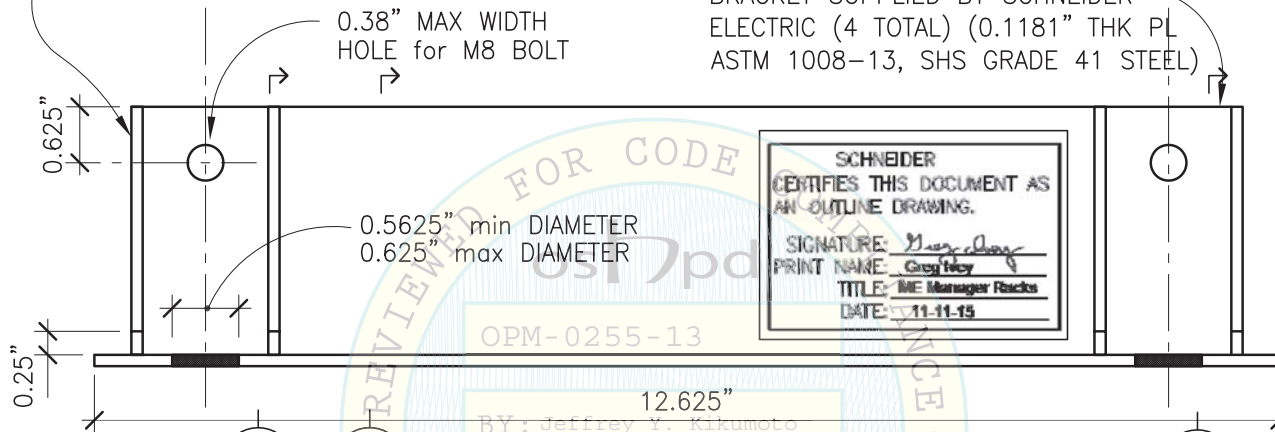

OPM-0255-13

BY: Jeffrey Y. Kikumoto

### SEISMIC BRACKET ELEVATION

**NOTE:**  
BRACKET SHALL BE FABRICATED  
BY SCHEINDER ELECTRIC WITH  
METRIC DIMENSIONS, PER  
SCHNEIDER STANDARDS

## DETAIL 1

N.T.S. SK11

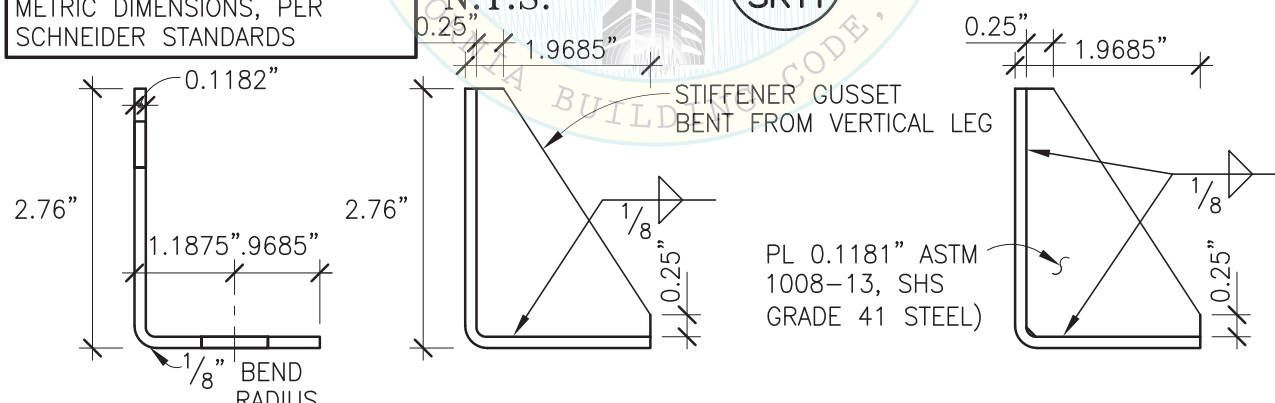

**SEC. B**  
N.T.S. SK11

**SEC. C**  
N.T.S. SK11

**SEC. D**  
N.T.S. SK11

<p>Robinson Meier Jully &amp; Associates</p> <p>241 Joaquin Avenue San Leandro CA 94577 510.991.0977</p>	<p>SCHNEIDER ELECTRIC NETSHELTER SX</p>	<p>Job No. 15262</p>
	<p>OSHPD CABINET SUPPORTS AND ATTACHMENTS</p>	<p>Sheet No. SK11</p>
	<p>Signed by JEH Date 11/14/2016</p>	