



MODEL #	VZ-WM50
FEATURES	
Net Weight	3 lbs / 1.36 kg
Net Weight + Screws	4 lbs / 1.81 kg
Weight Capacity	165 lbs / 75 kg
Dimension (Width x Height x Depth) inch	18.26 x 10.62 x 1.77
(Width x Height x Depth) mm	464 x 270 x 45
DIM Size (Width x Height x Depth) inch	18.26 x 7.99 x 0.59
(Width x Height x Depth) mm	464 x 203 x 15
Mounting Pattern Type	Universal / VESA
Universal Pattern	Range
VESA Patterns	200 x 200 (Min), 400 x 200 (Max) mm
Display Range	27.0" ~ 32.0"
Tilt	-10° ~ 0°
Profile	1.77" / 45 mm

PRECAUTIONS

- Do not exceed rated & listed weight. Serious injury or property damage may occur !
- Do not begin the installation until you have read and understood all the instructions and warnings contained in this installation sheet. If you have any questions regarding any of the instructions or warnings, please contact your local distributor.
- This mounting bracket was designed to be installed and unlisted ONLY as specified in this manual. Improper installation of this product may cause damage or serious injury.
- Tighten screws firmly, but do not over tighten. Over tightening can cause damage to the items, This greatly reduces their holding power.
- This product is intended for indoor use only. Using this product outdoors could lead to product failure and personal injury.

VZ-WM50 ADVANTAGES

- Universal Mounting Pattern
- Works with flat-panel mounts that have a VESA pattern
MIN. 200 x 200 mm, MAX. 400 x 200mm
- Fit for ViewZ Monitors 27" ~ 32 "
- -10° ~ 0° tilting
- 3 Year Warranty

Designed specifically for

- VZ-PVM-I3 & I4** HD Public View Monitor 27" & 32"
- VZ-PVM-Z3 & Z4** iP Public View Monitor 27" & 32"
- VZ-27, 32RTHL** Premium LED HD Monitor 27" & 32"

DIMENSIONS

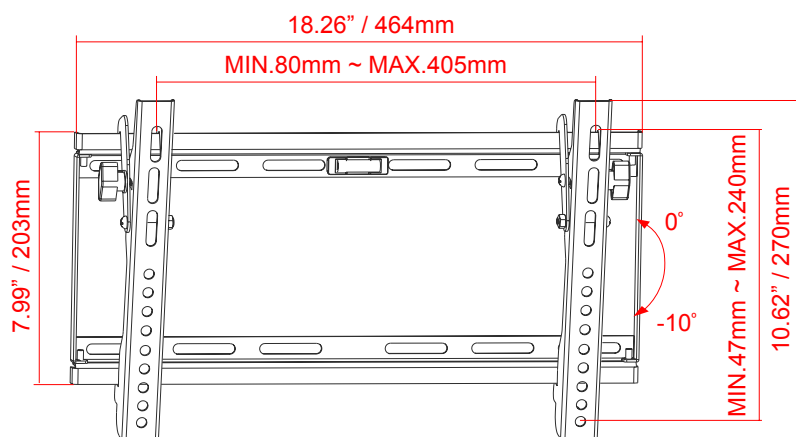

Contact ViewZ

- Address : 177 W. Orangethorpe Ave., Placentia, CA 92870
- Phone : (714) 996-1177, Fax : (714) 996-1138
- Sales : sales@viewzusa.com
- Specification subject to change without notice.