

VIKING

TECHNICAL Practice

TELECOM SOLUTIONS FOR THE 21ST CENTURY

E-50 Series
Compact Entry Phones
with Color Video Camera

September 2, 2021

Compact Video Entry Phones Available in Five Finishes



E-50-SS
"Brushed Stainless Steel"
(similar to brushed nickel) Shown with
optional VE-3x5 box (not included)



E-50-BN
"Oil Rubbed Bronze"
(satin dark brown powder
paint with fine copper metallic)



E-50-PB
"Polished Brass"
(with clear gloss powder
paint to prevent tarnishing)



E-50-WH
"Satin White"
(satin white powder paint)



E-50-BK
"Satin Black"
(fine texture satin black
powder paint)

The **E-50** Series Video Entry phones are compact, weather and vandal resistant speaker phones designed to provide two-way hands-free audio communication and color composite video of who is at your door or gate. The **E-50's** compact size allows it to be mounted in a standard single gang electrical box. The **E-50** is available in five different attractive finishes to match your door hardware, light fixtures, etc. Replacement **E-50** faceplates (**PNL50**) can be purchased separately and are available in all five standard finishes. The **E-50's** blue LED continually provides light for locating the push button in dark locations, dims to indicate off hook and flashes during incoming ring. The **E-50** entry phones can share a single phone line with house or small business telephones when used with a **Viking** model **C-200**, **C-250**, **C-500** or **C-2000B** Entry Phone controller. The **E-50** entry phones can also be connected to an unused analog station port (programmed for ring down) on a phone system or connected directly to a telephone line when used with a **Viking** model **K-1900-5** or **K-1900-30** auto dialer. The **E-50** features a built-in high resolution color video camera, microphone and speaker volume controls, selectable auto answer for monitoring and intelligent call progress detection for automatic hang-up when the call is completed. For outdoor installations where the unit is exposed to precipitation or condensation, the **E-50** Series is available with Enhanced Weather Protection (**EWP**), see **DOD 859**.

Features

- Built-in high resolution color video camera with wide viewing angle, tilt/swivel adjustments, and wide operating temperature of -30° F to 150° F
- Audio and video transmission on one CAT5E cable (see page 5)
- **Compact size:** Front panel is the size of a typical single gang midsize wall plate
- **Mounting:** Flush mount in a single gang electrical box (2.25" deep x 2.00" wide x 2.84" tall min) electrical box or surface mount in a Viking model **VE-3x5** (not included - **DOD# 424**)
- **Available in 5 standard faceplate finishes:** Brushed Stainless Steel, Oil Rubbed Bronze, Polished Brass, Satin White and Satin Black
- **PNL-50 faceplates:** Replacement faceplates with matching screws available in all five standard finishes
- **Vandal Resistant Features:** 16 gauge polished brass or 18 gauge 304 stainless steel faceplate, 316 stainless steel push button, carbon fiber reinforced plastic speaker screen, scratch resistant powder coating, impact and scratch resistant camera lens, and hex drive mounting screws
- **Weather Resistant Features:** Mylar speaker, faceplate gasket, mic and speaker gasket, internally sealed (IP67) push button switch, sealed camera lens, potted camera circuit board, stainless steel phone and camera mounting hardware and UV stable weather resistant powder coating (excluding **E-50-SS**)
- **E-50-EWP** is designed to meet IP66 Ingress Protection Rating (see **DOD 859**)
- Microphone and speaker volume controls
- Programmable Intelligent call progress detection for automatic hang-up on CPC, silence, busy signal, or time out
- Selectable auto answer feature for monitoring
- Programmable VOX (mic/speaker) switching speed
- **Blue LED** helps located push button, indicate ringing and off-hook

Applications

- Door or gate communication, business delivery entrances
- Use with a **Viking C-200** or **C-250** to control one **E-50** on a single phone line
- Use with a **Viking C-500** to control 1 or 2 (expandable to 8) **E-50's** and door/gate control on a single phone line
- Use with a **Viking C-2000B** to control 1 to 4 **E-50's** and door/gate control on a single phone line
- Provide unique front and back door chimes and paging when used with a **Viking SLP-1**, **SLP-4** and **C-2000B**
- Use with a **Viking K-1900-5** or **K-1900-30** for automatic speed dialing on telephone lines or analog PABX/KSU station ports
- Use on an analog PABX station port with programmable ringdown capability

Phone: 715.386.8861

www.VikingElectronics.com

Specifications

Dimensions: Faceplate: 4.875" x 3.125" x 0.18" (123.8mm x 79.4mm x 4.6mm),

Phone Board: 2.84" x 1.8" x 1.65" (72mm x 46mm x 42mm)

Shipping Weight: 1.0 lbs (0.45 kg)

Operating Temperature: -30° F to 150° F (-34° C to 65° C)

Connections: (5) gel-filled butt connectors (3M Scotchlok UR2)

(See page 2 for complete specifications)

IF YOU HAVE A PROBLEM WITH A VIKING PRODUCT, PLEASE CONTACT: VIKING TECHNICAL SUPPORT AT 715-386-8666

Our Technical Support Department is available for assistance Monday through Friday 8am - 5pm central time. So that we can give you better service, before you call please:

1. Know the model number, the serial number and what software version you have (see serial label).
2. Have your Technical Practice in front of you.
3. It is best if you are on site.

RETURNING PRODUCT FOR REPAIR

The following procedure is for equipment that needs repair:

1. Customer must contact Viking's Technical Support Department at 715-386-8666 to obtain a Return Authorization (RA) number. The customer MUST have a complete description of the problem, with all pertinent information regarding the defect, such as options set, conditions, symptoms, methods to duplicate problem, frequency of failure, etc.
2. Packing: Return equipment in original box or in proper packing so that damage will not occur while in transit. Static sensitive equipment such as a circuit board should be in an anti-static bag, sandwiched between foam and individually boxed. All equipment should be wrapped to avoid packing material lodging in or sticking to the equipment. Include ALL parts of the equipment. C.O.D. or freight collect shipments cannot be accepted. Ship cartons prepaid to:
Viking Electronics, 1531 Industrial Street, Hudson, WI 54016
3. Return shipping address: Be sure to include your return shipping address inside the box. We cannot ship to a PO Box.
4. RA number on carton: In large printing, write the R.A. number on the outside of each carton being returned.

RETURNING PRODUCT FOR EXCHANGE

The following procedure is for equipment that has failed out-of-box (within 10 days of purchase):

1. Customer must contact Viking's Technical Support at 715-386-8666 to determine possible causes for the problem. The customer MUST be able to step through recommended tests for diagnosis.
2. If the Technical Support Product Specialist determines that the equipment is defective based on the customer's input and troubleshooting, a Return Authorization (R.A.) number will be issued. This number is valid for fourteen (14) calendar days from the date of issue.
3. After obtaining the R.A. number, return the approved equipment to your distributor, referencing the R.A. number. Your distributor will then replace the product over the counter at no charge. The distributor will then return the product to Viking using the same R.A. number.
4. **The distributor will NOT exchange this product without first obtaining the R.A. number from you. If you haven't followed the steps listed in 1, 2 and 3, be aware that you will have to pay a restocking charge.**

TWO YEAR LIMITED WARRANTY

Viking warrants its products to be free from defects in the workmanship or materials, under normal use and service, for a period of two years from the date of purchase from any authorized Viking distributor. If at any time during the warranty period, the product is deemed defective or malfunctions, return the product to Viking Electronics, Inc., 1531 Industrial Street, Hudson, WI., 54016. Customer must contact Viking's Technical Support Department at 715-386-8666 to obtain a Return Authorization (R.A.) number.

This warranty does not cover any damage to the product due to lightning, over voltage, under voltage, accident, misuse, abuse, negligence or any damage caused by use of the product by the purchaser or others. This warranty does not cover non-EWP products that have been exposed to wet or corrosive environments. This warranty does not cover stainless steel surfaces that have not been properly maintained.

NO OTHER WARRANTIES, VIKING MAKES NO WARRANTIES RELATING TO ITS PRODUCTS OTHER THAN AS DESCRIBED ABOVE AND DISCLAIMS ANY EXPRESS OR IMPLIED WARRANTIES OR MERCHANTABILITY OR FITNESS FOR ANY PARTICULAR PURPOSE.

EXCLUSION OF CONSEQUENTIAL DAMAGES. VIKING SHALL NOT, UNDER ANY CIRCUMSTANCES, BE LIABLE TO PURCHASER, OR ANY OTHER PARTY, FOR CONSEQUENTIAL, INCIDENTAL, SPECIAL OR EXEMPLARY DAMAGES ARISING OUT OF OR RELATED TO THE SALE OR USE OF THE PRODUCT SOLD HEREUNDER.

EXCLUSIVE REMEDY AND LIMITATION OF LIABILITY. WHETHER IN AN ACTION BASED ON CONTRACT, TORT (INCLUDING NEGLIGENCE OR STRICT LIABILITY) OR ANY OTHER LEGAL THEORY, ANY LIABILITY OF VIKING SHALL BE LIMITED TO REPAIR OR REPLACEMENT OF THE PRODUCT, OR AT VIKING'S OPTION, REFUND OF THE PURCHASE PRICE AS THE EXCLUSIVE REMEDY AND ANY LIABILITY OF VIKING SHALL BE SO LIMITED.

IT IS EXPRESSLY UNDERSTOOD AND AGREED THAT EACH AND EVERY PROVISION OF THIS AGREEMENT WHICH PROVIDES FOR DISCLAIMER OF WARRANTIES, EXCLUSION OF CONSEQUENTIAL DAMAGES, AND EXCLUSIVE REMEDY AND LIMITATION OF LIABILITY, ARE SEVERABLE FROM ANY OTHER PROVISION AND EACH PROVISION IS A SEPARABLE AND INDEPENDENT ELEMENT OF RISK ALLOCATION AND IS INTENDED TO BE ENFORCED AS SUCH.

FCC REQUIREMENTS

This equipment complies with Part 68 of the FCC rules and the requirements adopted by the ACTA. Inside the front panel of this equipment is a label that contains, among other information, a product identifier in the format US:AAAEQ##TXXXX. If requested, this number must be provided to the telephone company.

The REN is used to determine the number of devices that may be connected to a telephone line. Excessive REN's on a telephone line may result in the devices not ringing in response to an incoming call. In most but not all areas, the sum of the REN's should not exceed five (5.0). To be certain of the number of devices that may be connected to a line, as determined by the total REN's, contact the local telephone company. For products approved after July 23, 2001, the REN for this product is part of the product identifier that has the format US:AAAEQ##TXXXX. The digits represented by ## are the REN without a decimal point (e.g., 03 is a REN of 0.3). For earlier products, the REN is separately shown on the label.

The plug used to connect this equipment to the premises wiring and telephone network must comply with the applicable FCC Part 68 rules and requirements adopted by the ACTA. If your home has specially wired alarm equipment connected to the telephone line, ensure the installation of this E-50 does not disable your alarm equipment. If you have questions about what will disable alarm equipment, consult your telephone company or a qualified installer.

If the E-50 causes harm to the telephone network, the telephone company will notify you in advance that temporary discontinuance of service may be required. But if advance notice isn't practical, the telephone company will notify the customer as soon as possible. Also, you will be advised of your right to file a complaint with the FCC if you believe it is necessary.

The telephone company may make changes in its facilities, equipment, operations, or procedures that could affect the operation of the equipment. If this happens, the telephone company will provide advance notice in order for you to make

the necessary modifications to maintain uninterrupted service.

If trouble is experienced with the E-50, for repair or warranty information, please contact:

Viking Electronics, Inc., 1531 Industrial Street, Hudson, WI 54016 (715) 386-8666

If the equipment is causing harm to the telephone network, the telephone company may request that you disconnect the equipment until the problem is resolved.

Connection to Party Line Service is subject to State Tariffs. Contact the state public utility commission, public service commission or corporation commission for information.

WHEN PROGRAMMING EMERGENCY NUMBERS AND (OR) MAKING TEST CALLS TO EMERGENCY NUMBERS:

Remain on the line and briefly explain to the dispatcher the reason for the call. Perform such activities in the off-peak hours, such as early morning or late evenings.

It is recommended that the customer install an AC surge arrester in the AC outlet to which this device is connected. This is to avoid damaging the equipment caused by local lightning strikes and other electrical surges.

PART 15 LIMITATIONS

This equipment has been tested and found to comply with the limits for a Class A digital device, pursuant to Part 15 of the FCC Rules. These limits are designed to provide reasonable protection against harmful interference when the equipment is operated in a commercial environment. This equipment generates, uses, and can radiate radio frequency energy and, if not installed and used in accordance with the instruction manual, may cause harmful interference to radio communications. Operation of this equipment in a residential area is likely to cause harmful interference in which case the user will be required to correct the interference at his own expense.

Specifications

Entry Phone Specifications

Power: Telephone line powered. Minimum 18V DC talk battery voltage with a minimum loop current of 20mA. Loop current may be boosted on low current lines with a Viking model **TBB-1B** Talk Battery Booster (see **DOD 632**).

Dimensions: Faceplate: 123.8mm x 79.4mm x 4.6mm (4.875" x 3.125" x 0.18"), Phone Board: 71mm x 46mm x 42mm (2.8" x 1.8" x 1.65")

Speaker Volume: Approximately 62db maximum @ 1m

Ring Voltage: 25V AC RMS minimum (for auto answer)

CPC Disconnect Time: 300ms minimum

REN: 0.8A

Camera Specifications

Power: 6-22V DC regulated 150mA (12V DC UL Listed adapter included)

Image Sensor: 1/4" color CMOS

Video Output: 1 VP-P composite, NTSC, 75 ohms

Resolution: 420 lines (640 x 480 @ 30fps / 307,200 pixels)

Sensitivity: 0.025 LUX (50 IRE) F 1.2 3200K

Lens: 2.1mm, conical pinhole

FOV(Field of View): 80° Horizontal, 60° Vertical, 100° Diagonal

Tilt/Swivel Adjustment: Vertical +/- 20°, horizontal +/- 30° (see **Diagram A**)

IR Compatibility: This camera is equipped with an OLP (Optical Low Pass) filter to maintain correct video color in outside applications. The standard camera is **NOT** compatible with IR illuminators. If IR illumination is required, you will need to replace the existing camera with a Viking model **VCAM-11R**. For more information, see **DOD 190**.

Maximum Wire Run Length: 1000 ft with *RG59/RG6 for video and CAT5 for power (1 pair) and entry phone audio (1 pair). 150 ft with CAT5E for video, power and entry phone audio (longer video runs are possible by using video balun transceivers, see **Installation F**, page 5).

2 * **Note:** RG59 or RG6 with solid center conductor and 95% bare copper braid shield.

Entry Phone / Camera Specifications

Operating Temperature: -34° C to 65° C (-30° F to 150° F)

Humidity: Standard model: 5% to 95% non-condensing, EWP model: Up to 100%

Connections: (5) gel-filled butt connectors (3M Scotchlok UR2)

Shipping Weight: 0.45 kg (1.0 lbs)

Recommended Electrical Box for Flush Mounting: Single gang with minimum inside dimensions of 2.25" deep x 2.00" wide x 2.84" tall (Allied molded 9331 or equivalent)

Recommended Surface Mount Box: Viking model **VE-3x5** (**DOD 424**)

WARNING: Do **NOT** use a typical "wet location box" as not all styles seal properly with the **E-50** faceplate.

Diagram A Camera Horizontal Field of View:

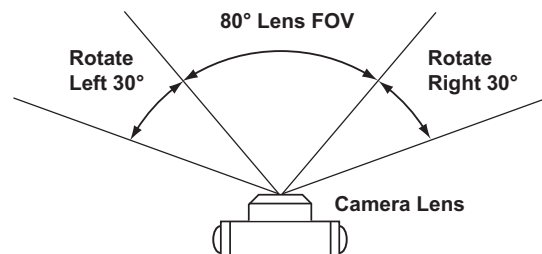

Features Overview

Microphone: Omni-directional microphone with protective water-resistant cloth.

Faceplate: 18 gauge 304 stainless steel or 16 gauge polished brass faceplate with super durable UV stable powder paint to prevent fading and resist scratching.

Speaker: Mylar speaker with rubber gasket to maintain water-tight seal and eliminate water deterioration.

Speaker Screen: Stainless steel speaker screen with 0.018" diameter holes to prevent punctures from paperclips, etc.

Color Video Camera: Wide operating temperature range of -30°F to 150°F, NTSC composite video output with 420 lines of resolution, 80° wide viewing angle lens, tilt and swivel adjustments for aiming towards visitors.

Protective Camera Window: Impact resistant polycarbonate lens with scratch resistant coating and water-tight gasket.

Mounting Screws: 6-32 x 1.25" long flathead with 5/64" hexdrive, 18-8 stainless steel to prevent corrosion.

Blue LED: Helps locate the push button in dark locations, indicates paging and off-hook conditions.

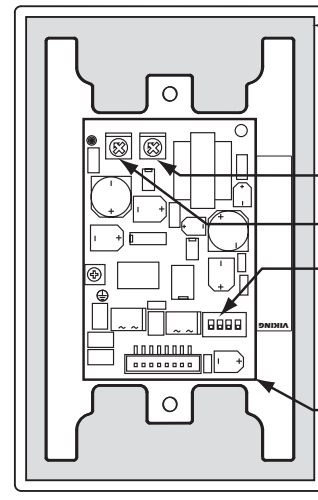
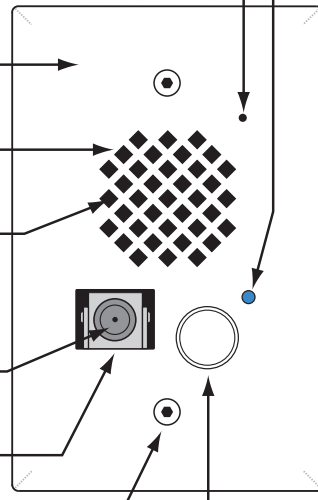

Faceplate Gasket: 1/4" thick closed cell PVC to water-tight seal faceplate, speaker, switch and microphone.

Speaker Volume

Microphone Volume

Dip Switches:

1. Auto Answer
2. Dial Tone Detection
3. Programming
4. LED On/Off

Entry Phone Board: Compact analog speaker phone with call progress detection for automatic disconnect.

Push Button Switch: Push to initiate call, push again to disconnect. Solid 304 stainless steel internally sealed per IP67.

Installation

The **E-50** is designed to be flush mounted into a standard single gang rough-in box with minimum inside dimensions of 2.25" deep x 2.00" wide x 2.84" tall. The **E-50** can also be surface mounted in a Viking model **VE-3x5** (not included, see **DOD 424**).

WARNING: Do **NOT** use a typical "wet location box" as not all styles seal properly with the **E-50** faceplate.

A. New Construction Flush Mounting

Step 1.	Recommended mounting height to bottom of the rough-in box is 50" - 54". Front of box should stick out approximately 1/2" from front surface of wall stud (this may vary depending on the walls sheathing and siding thickness). Caution: Rough-In box must be mounted LEVEL and must NOT stick out beyond the front surface of siding.
Step 2.	To maintain a vapor barrier on outside wall applications, caulk around the box, filling any gaps between the box and the rough opening. Apply caulk to any holes in the box around wires, etc.
Step 3.	When installing siding cut a hole just large enough for the Rough-In box opening. Caution: Too large of a hole can cause plate misalignment and compromise the gasket seal. Note: When mounting to 4 inch or less horizontal lap siding, the unit can be mounted horizontally (see page 5, section H) flush against siding or a siding mounting block can be used (recommended with vinyl siding). Contact siding installer for the correct mounting block.

B. Old Work / Remodel Flush Mounting (Using a recommended Allied Molded 9331 Rough-In Box)

Step 1.	Recommended mounting height to bottom of the rough-in box is 50" - 54". Make sure mounting location is free of wall studs, wires, etc.
Step 2.	Place Rough-In box LEVEL against siding. Trace outline of box onto siding. Note: When mounting to 4 inch or less horizontal lap siding, the unit can be mounted horizontally (see page 5, section H) flush against siding or a siding mounting block can be used. Contact your siding Installer for the correct mounting block part number. Note: A siding mounting block is recommended when mounting to vinyl siding.
Step 3.	Cut a hole through the siding and wall sheathing just large enough for the rough-in box. Caution: Too large of a hole can cause plate misalignment and compromise the gasket seal.
Step 4.	The front surface of the Rough-In box can be mounted flush against wood siding or can be recessed and mounted flush against wall sheathing when mounting on aluminum, steel or vinyl siding.
Step 5.	When mounting to 5/8 inch thick or less wall sheathing the two attached screws with wing brackets can be used to secure the rough-in box. When mounting to surfaces thicker than 5/8 inch, four standard flat head dry wall screws can be used to secure the Rough-In box through its mounting ears (see page 4 section D).
Step 6.	To maintain a vapor barrier on outside wall applications, caulk around the box, filling any gaps between the box and the rough opening. Apply caulk to any holes in the box around wires, etc.

C. Surface Mounting

A Viking model **VE-3x5** can be used to surface mount an **E-50** to a wall or post. Recommended mounting height to bottom of **VE-3x5** is 50" - 54". Drill a small wire exit hole in wall. Pull wire through and seal hole around wire with putty or caulking. Route wire into the **VE-3x5** box, securely screw it to wall or post and seal hole in box around wire with putty or caulking. **Note:** Conduit may also be used when surface mounting wire, but should not enter through the top of the **VE-3x5**. When routing wiring from above, a drip loop is required. **WARNING:** Do **NOT** use a typical "wet location box" as not all styles seal properly with the **E-50** faceplate.

D. Mounting the Faceplate

After the Rough-In box or **VE-3x5** is securely mounted, caulking between the box and rough opening is completed (if required), wires are connected, and camera is tilted and rotated to the desired position (as shown in section **G**). Remove paper liner from face plate gasket, while firmly holding the LED light pipe in the faceplate, carefully slide the faceplate gasket over the back of the light pipe and press gasket to the back of the faceplate. Push the 1-1/4" 6-32 screws through faceplate holes and small holes in gasket, the faceplate gasket should retain the screws. Position the circuit board mounting plate over screws. Align screws with single gang box bosses and tighten face plate until gasket is fully collapsed and the push button is protruding through the clearance hole in the face plate. Included 1/4" thick gasket will provide an adequate seal for most siding surfaces; however for rough surfaces (ie: brick, stucco, etc.) additional caulking may be required.

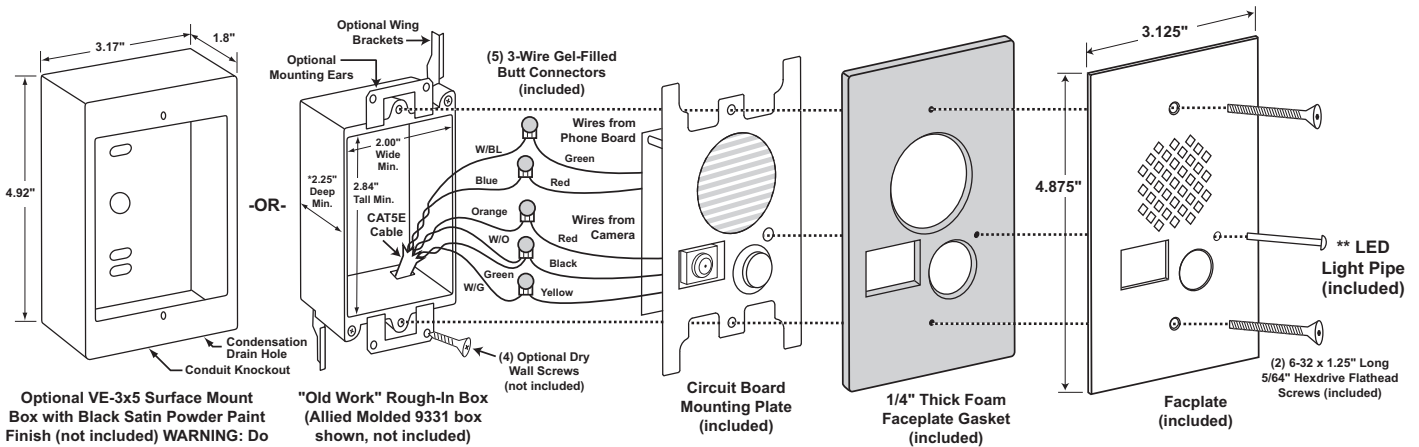

* **CAUTION:** Excessive wire length and/or using a rough-in box with inadequate depth can apply force to the circuit board causing physical damage.

** **Important:** Push LED light pipe into faceplate hole, then place faceplate upside down on a clean flat surface and push down on back side of plate until light pipe is fully seated and straight. **WARNING:** Inserting the light pipe more than one time can cause a loose fit.

E. Wiring the E-50 Phone Board

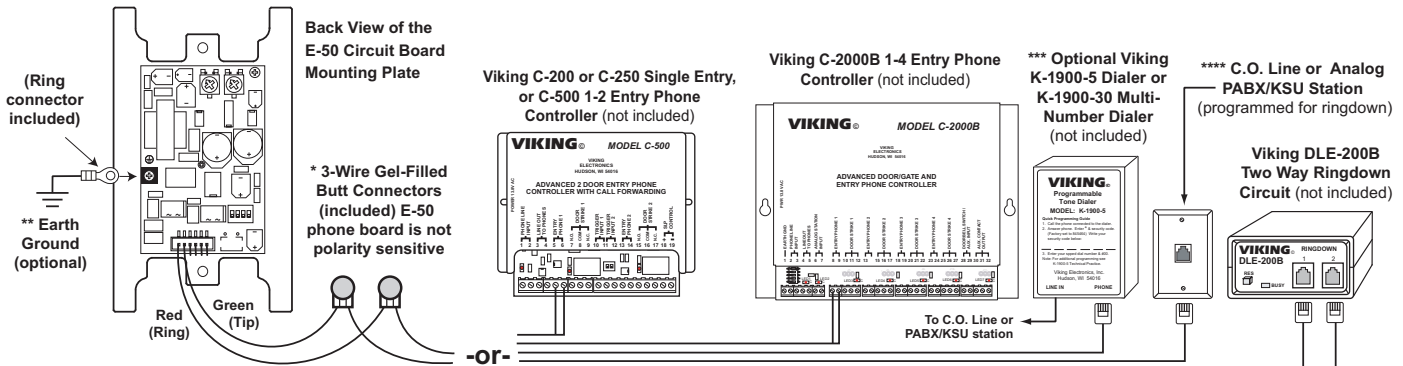

IMPORTANT: Electronic devices are susceptible to lightning and power station electrical surges from both the AC outlet and the telephone line. It is recommended that a surge protector be installed to protect against such surges.

* **Note:** The gel-filled (water-tight) butt connectors (3M Scotchlok UR2) are designed for insulation displacement on 19-26 gauge wire with a maximum insulation of 0.082 inches. Do not strip wires prior to terminating.

** **Note:** To increase surge protection, loosen the PCB mounting screw labeled \oplus (as shown above) and fasten a wire with ring terminal (included) from the mounting screw to Earth Ground (grounding rod, water pipe, etc.) After fastening ring terminal to PCB mounting screw, bend terminal up to avoid interference with single gang box.

*** **Note:** Talk battery must be a minimum of 28V DC when using the speaker phone with a Viking **K-1900-5 Dialer (DOD# 317)** or **K-1900-30 Multi-Number Dialer (DOD# 300)**.

**** **Note:** When installing a line powered phone on a low voltage and/or low loop current phone system extension, a Viking **TBB-1B Talk Battery Booster** may be required, see **DOD# 632**.

F. Wiring the E-50 Camera

1. Using RG59 for Video and CAT5 for Camera Power and Phone Board Audio (Recommended)

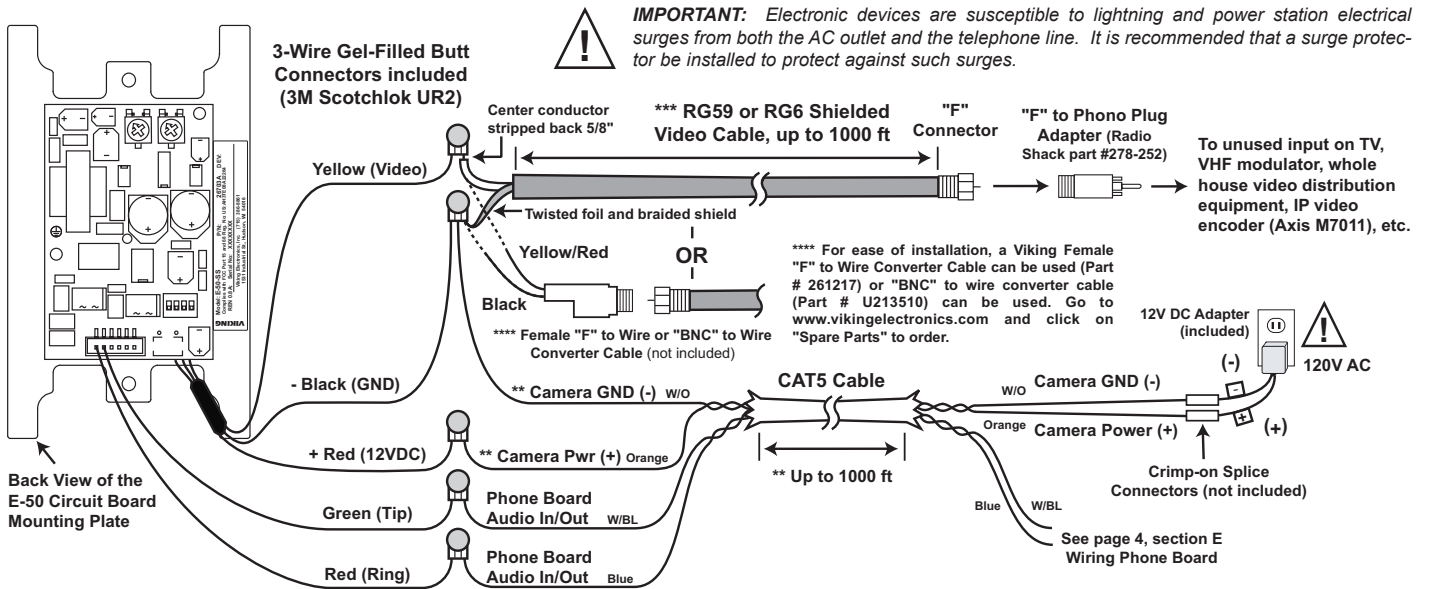

2. Using CAT5E or CAT6 for Video, Camera Power and Phone Board Audio (see Caution below)

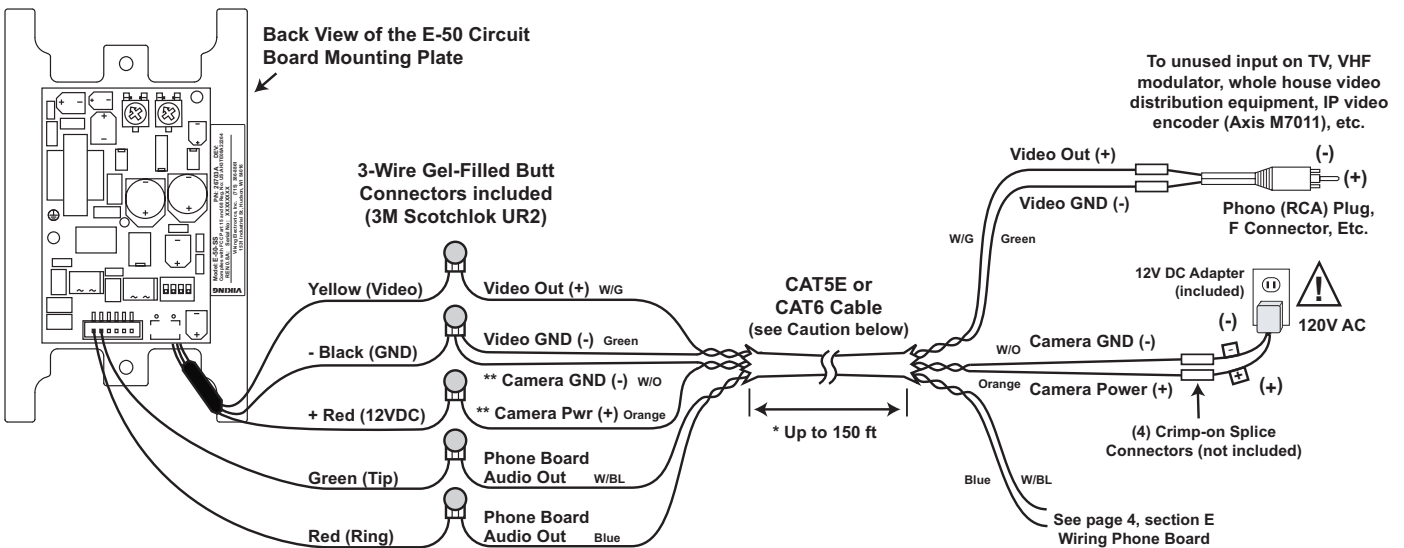

* **Note:** Up to 150 ft video cable run length can be achieved using CAT5E or CAT6 cable. Longer cable runs can be used if a passive or active video Balun transceiver is used on each end of the cable. Generally, passive transceivers can achieve up to 750 ft cable runs where active transceivers can achieve up to 3000 ft runs depending on cable type, etc. The type of video balun transceiver required is specific to your cable run length. For more information on video balun transceivers go to: www.northernvideo.com.

** **Note:** The maximum camera power supply wire run length is 1000 ft of 24 gauge wire (CAT 5/6), longer runs are possible by doubling pairs, increasing the wire gauge or using up to a 22V DC 200mA power adapter.

*** **Note:** RG59 or RG6 with solid center conductor and 95% bare copper braid shield.

Caution: When routing CAT5E or CAT6 cable, maintain a minimum distance of 3 ft from any parallel high voltage wire (110 VAC) and a minimum of 2 ft from crossing any high voltage wire. For installations where RF noise is expected (commercial applications) or wire runs are near high voltage (110 VAC) wires, a shielded video cable such as RG6 is recommended.

G. Adjusting the Camera

The camera can be tilted and rotated to your desired position. A portable service (test) monitor can be used to determine the correct viewing angle during installation.

Important: To prevent the edge of the faceplate from being viewed in the video image, do not rotate the camera beyond 30 degrees or tilt beyond 20 degrees.

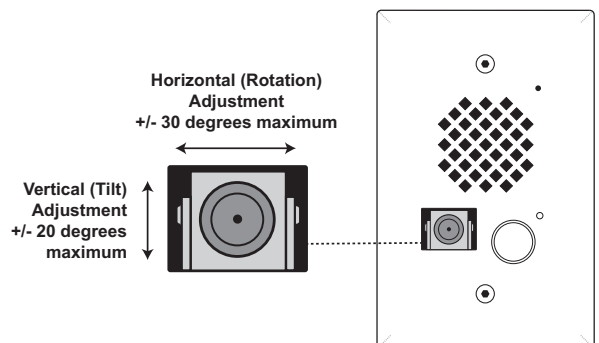

H. Repositioning the Camera when Mounting the E-50 Horizontal

(Requires Viking model LB-50 Camera L-Bracket - not included with the E-50)

When mounting the **E-50** to 4 inch or less horizontal lap siding, the unit can be mounted horizontally. When doing so, the internal video camera will have to be repositioned (vertically rotated 90 degrees) to correct the video image orientation. An additional camera "L" bracket (Viking model **LB-50**) is required to reposition the camera. To purchase **LB-50** contact your local Viking distributor.

To install the **LB-50**, remove the bottom #2 screw and lock washer which fastens the camera "U" bracket to the circuit board mounting plate. Remove the two screws mounting the camera to the "U" bracket. Rotate the camera 180 degrees so the video output wires exit the lower back plate of the camera and refasten it to the "U" bracket. Use the #2 screw and lock washer to attach the **LB-50** "L" bracket to the mounting plate then attach the camera to the "L" bracket with the screw and lock washer supplied with the **LB-50** as shown in the diagram. **Note:** Mounting the **E-50** horizontally will reduce the camera horizontal adjustment to +/- 20 degrees and increase the vertical tilt to +/- 30 degrees.

* **Caution:** When mounting the camera horizontally on a model **E-50-EWP**, the single gang rough in box may require trimming to allow room for the new camera position.

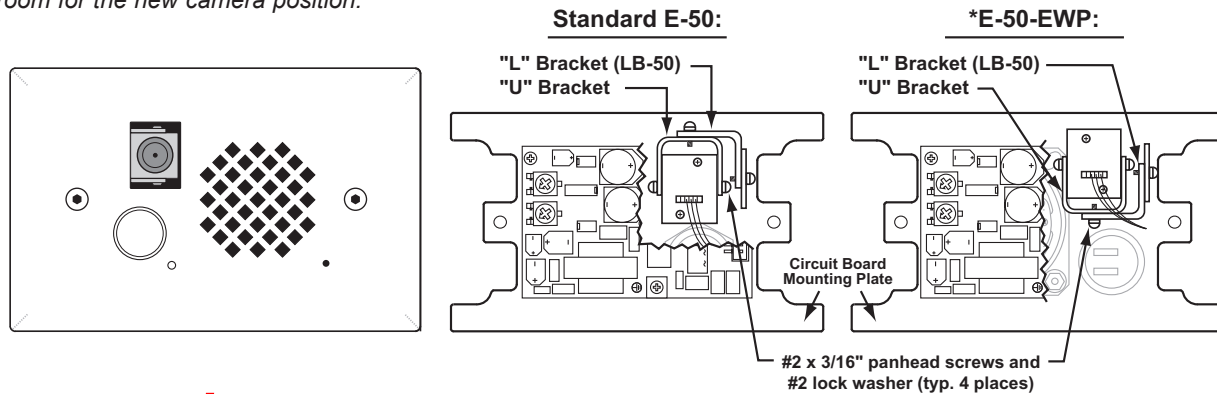

Programming

A. Adjusting Speaker Volume

The speaker volume pot can be adjusted to increase or decrease the speaker volume to the level desired.

B. Adjusting the Microphone Volume

In certain noisy locations (background traffic, machinery or wind), the microphone volume may need to be decreased. A symptom of this is one-way talk path, in which the distant party cannot be heard over the speaker. A microphone volume pot is provided for increasing or decreasing the microphone volume. **Note:** If the microphone volume is set too high or too low, one-way talk path may occur.

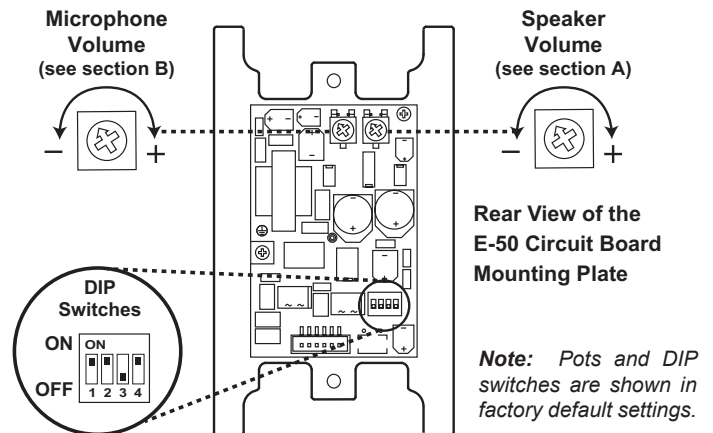

C. DIP Switch Programming

1. Auto Answer Feature ON/OFF (DIP Switch 1)

DIP switch 1 is for turning the Auto Answer feature ON and OFF. The **E-50** is factory set to auto answer when an inbound call is detected.

2. Dial Tone Detection ON/OFF (DIP Switch 2)

With DIP switch 2 in the ON position, if the **E-50** detects more than 5 seconds of continued dial tone, the unit will automatically disconnect. If the **E-50** is installed on a continuously noisy line, it may detect the noise as dial tone and automatically disconnect. If this happens, turn the dial tone detection (DIP switch 2) OFF.

3. Programming Mode ON/OFF (DIP Switch 3)

With DIP switch 3 in the OFF position, the **E-50** is in the "Normal Operation Mode" (factory setting). By placing DIP switch 3 in the ON position, the **E-50's** programming mode is enabled. The programming mode is used for adjusting the Call Length Time Out, Silence Time for automatic disconnect and the Talk/Listen delay (VOX switching speed). These features are set from the factory and normally do not need adjustment. If adjustment is necessary, see **Programming** sections **D - I**.

4. LED On/Off (DIP Switch 4)

With DIP switch 4 in the ON position, the blue faceplate LED will remain on at all times (to help locate push button switch in dark locations), dim to indicate off hook and flash to indicate incoming ring. When connecting an **E-50** to a C.O. line, turn the LED off to comply with FCC regulations.

Switch	Position	Description
1	ON	Auto-Answer ON *
1	OFF	Auto-Answer OFF
2	ON	Dial Tone Detection ON *
2	OFF	Dial Tone Detection OFF
3	ON	Programming Mode
3	OFF	Normal Operation Mode *
4	ON	LED On *
4	OFF	LED Off

* **Note:** These are the factory settings.

D. Accessing the Programming Mode

The **E-50** can be programmed from any Touch Tone phone using a telephone line, Viking model **C-200**, **C-250**, **C-500** or **C-2000B** Entry Phone Controller, analog PABX/KSU station or a Viking model **DLE-200B** Line Simulator.

Step 1.	Move DIP switch 1 to the ON position (sets unit to answer incoming calls - see section C).
Step 2.	Move DIP switch 3 to ON (incoming calls automatically enter the programming mode - see section C).
Step 3.	From a Touch Tone phone call the line attached to the E-50 .
Step 4.	When the E-50 answers, 2 beeps will be heard and you will automatically enter the programming mode.
Step 5.	When finished programming, enter " 0000 " to exit programming and move DIP switch 3 back to OFF (see section C).

E. Quick Programming Features

	Select Feature	Wait for Beep(s)	Enter Time Value	Wait for 2 Beeps
Call length time out (1-9 minutes), 10 = disabled (factory set to 11111 = 5 minutes)	0	beep	111...	beep beep
Silence time out for disconnect (10-90 seconds), 10 = disabled (factory set to 1111 = 40 secs)	00	beep	111...	beep beep
Talk/listen delay (VOX switching speed) 0.1 - 0.9 seconds (factory set to 111 = 0.3 secs)	000	beep	111...	beep beep
Forced hang-up command (used to exit programming and hang up the E-50)	0000	3 beeps		

See **Table A** in section **G** 

F. Programming Beeps

If a valid "**Feature**" is entered, a single beep will be heard and you will have 20 seconds to enter a "**Time**" value. If an invalid "**Feature**" (five or more zeros) or forced hang-up command (four zeros) is entered, 3 beeps will be heard and the **E-50** will hang up. If a valid "**Time**" is entered 2 beeps will be heard and you will have 20 seconds to enter your next "**Feature**". If an invalid "**Talk/Listen Delay Time**" is entered (10 or more ones), 3 beeps will be heard and you will have 20 seconds to enter your next "**Feature**".

G. Call Length Time Out

This feature selects the maximum length of time that calls can be connected. Programmable in increments of 1 minute up to a maximum of 9 minutes. To disable the call length time out, program ten ones in the "**Time**" value location. With the call length disabled, the **E-50** phone must rely on CPC, busy, silence or return dial tone to hang-up. Use the chart at the right. * **Note:** *The factory default is 5 minutes.*

Table A

Time Value	Call Length Time Out	Silence Time Out	Talk/Listen Delay
1	1 min	10 sec	.1 sec
11	2 min	20 sec	.2 sec
111	3 min	30 sec	.3 sec*
1111	4 min	40 sec*	.4 sec
11111	5 min*	50 sec	.5 sec
111111	6 min	60 sec	.6 sec
1111111	7 min	70 sec	.7 sec
11111111	8 min	80 sec	.8 sec
111111111	9 min	90 sec	.9 sec
10 or more	Disabled	Disabled	Error

H. Silence Time Out

This feature selects the length of time that calls will remain connected without voice activity. Programmable in increments of 10 seconds up to a maximum of 90 seconds. To disable the silence time out, program ten ones in the "**Time**" value location. Use the chart at the right. * **Note:** *The factory default is 40 seconds.*

I. Talk/Listen Delay (VOX Switching Speed)

This feature selects switching time between talk and listen modes (VOX switching time). Use the chart above.

* **Note:** *The factory default is .3 seconds.*

Operation

When the push button is pressed, the **E-50** phone goes off-hook, much like a standard speaker phone. In the event that the line is busy, the **E-50** will hang-up. The **E-50** will also automatically hang up on CPC, silence, busy signal, return to dial tone or time out. If programmed to auto-answer (DIP switch 1 **ON**), the **E-50** will also answer any incoming call.

The **E-50** color video camera operates completely independently of the **E-50** phone board. With power supplied to the camera, it will continuously output a video signal.

Applications

A. 1 or 2 (Expandable to 8) E-50's Sharing a Single Line with Optional Call Forwarding and Doorstrike/Gate Control

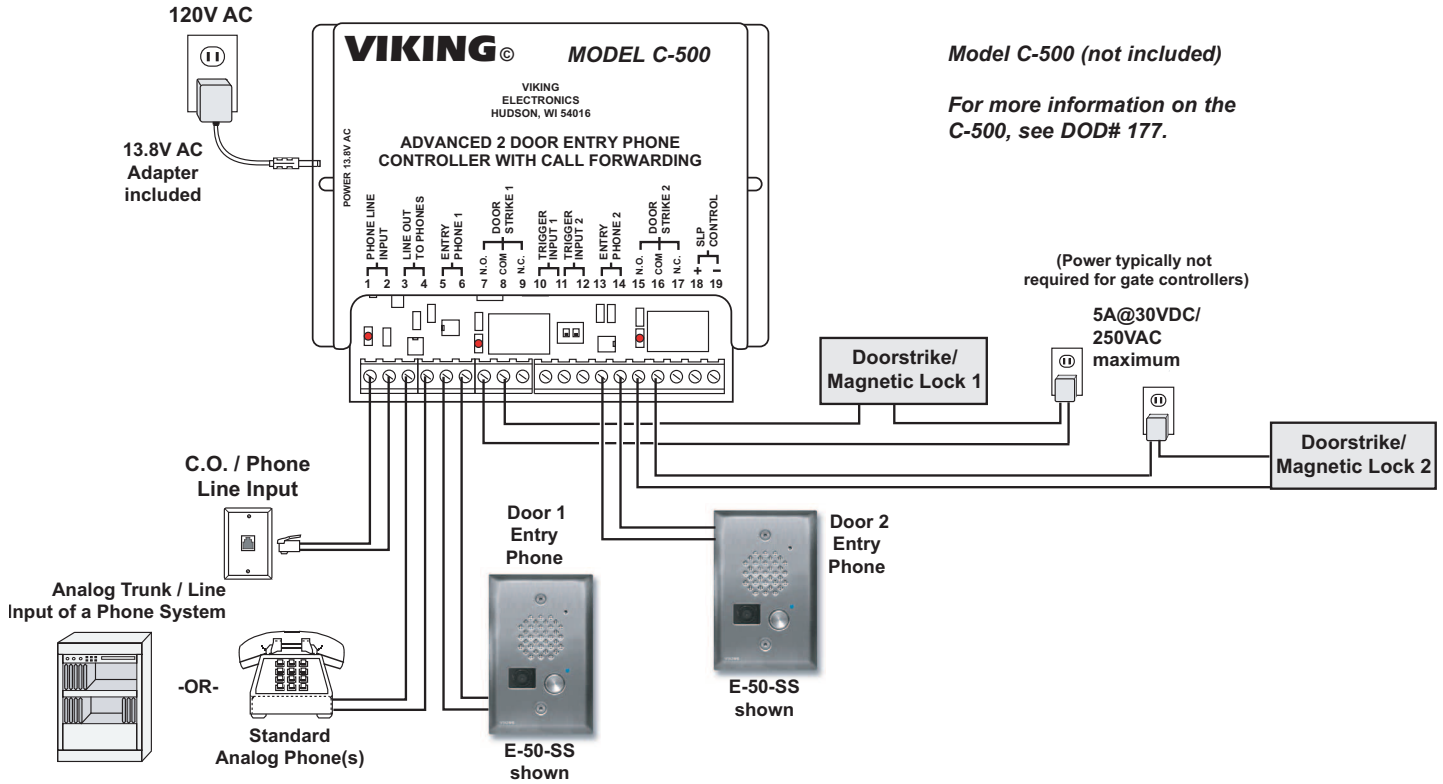

B. One to Four Entry Phones Sharing a Single Phone Line with Optional Keyless Entry, Doorstrike/Gate Control, and Entry Phone Caller ID

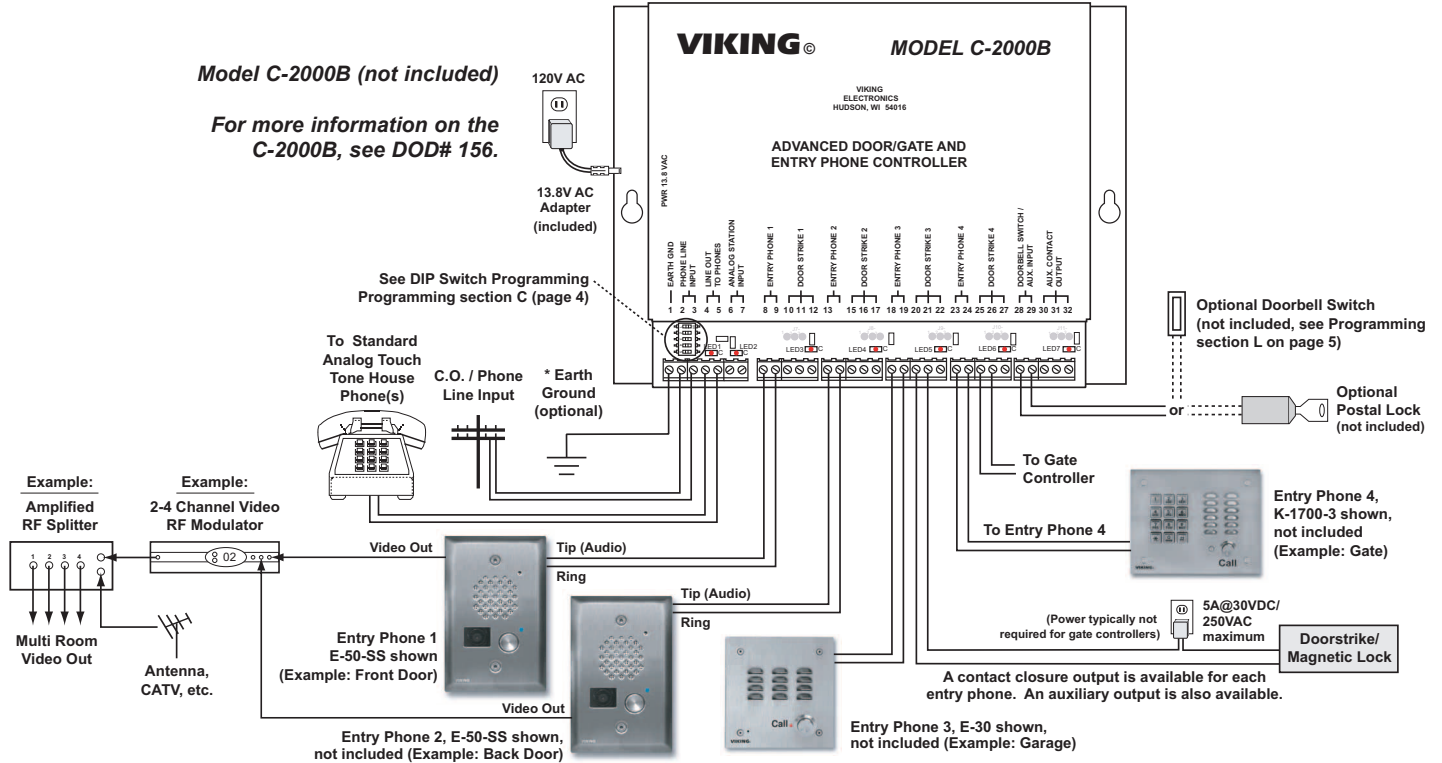

Product Support: 715-386-8666

Due to the dynamic nature of the product design, the information contained in this document is subject to change without notice. Viking Electronics, and its affiliates and/or subsidiaries assume no responsibility for errors and omissions contained in this information. Revisions of this document or new editions of it may be issued to incorporate such changes.