

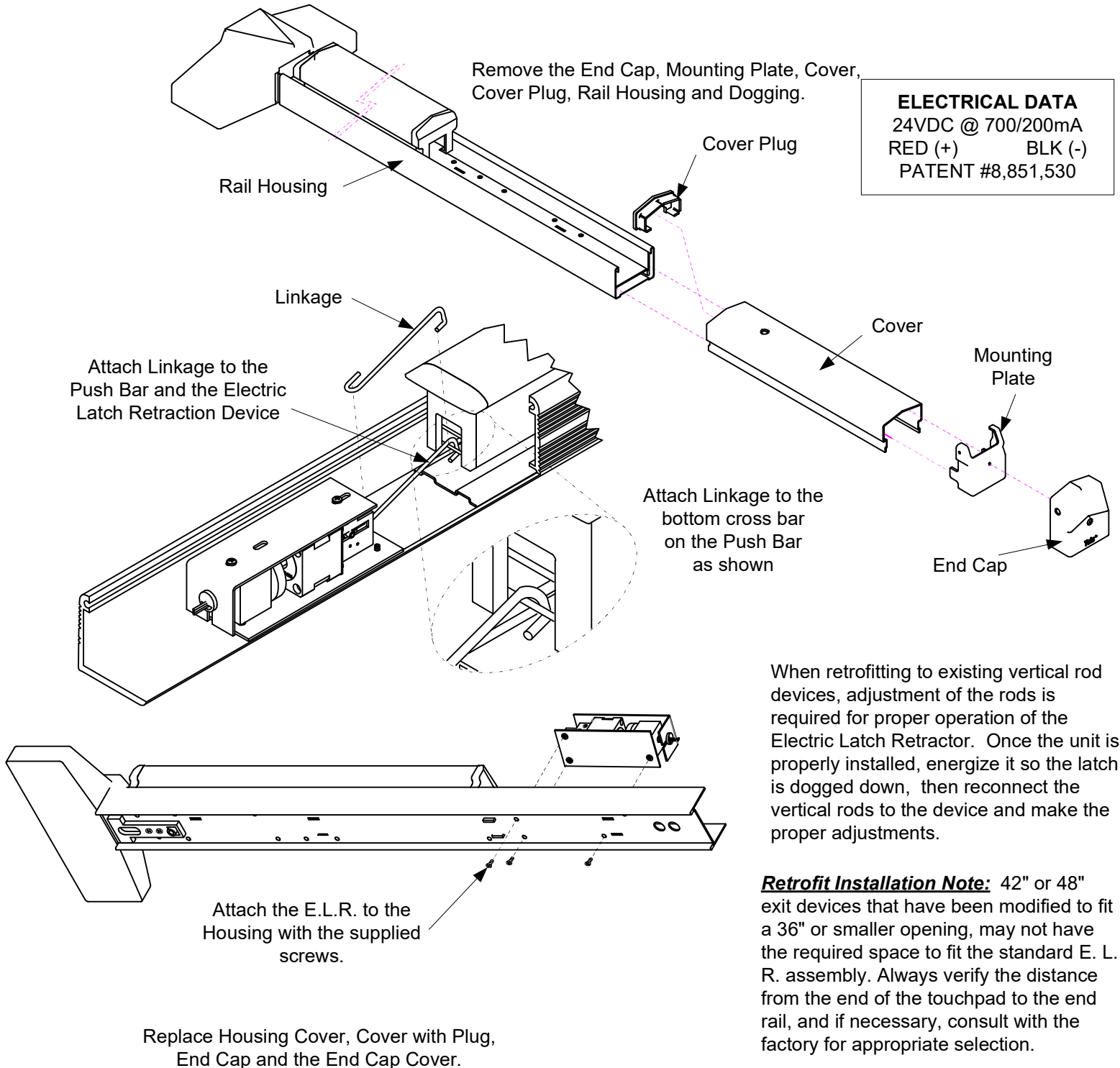

INSTALLATION INSTRUCTIONS

LR100CRK-EM CORBIN/RUSSWIN ELECTRIC LATCH RETRACTION DEVICE KIT MODELS: ED4200, ED5200, ED5400 & ED5800



When retrofitting to existing vertical rod devices, adjustment of the rods is required for proper operation of the Electric Latch Retractor. Once the unit is properly installed, energize it so the latch is dogged down, then reconnect the vertical rods to the device and make the proper adjustments.

Retrofit Installation Note: 42" or 48" exit devices that have been modified to fit a 36" or smaller opening, may not have the required space to fit the standard E. L. R. assembly. Always verify the distance from the end of the touchpad to the end rail, and if necessary, consult with the factory for appropriate selection.

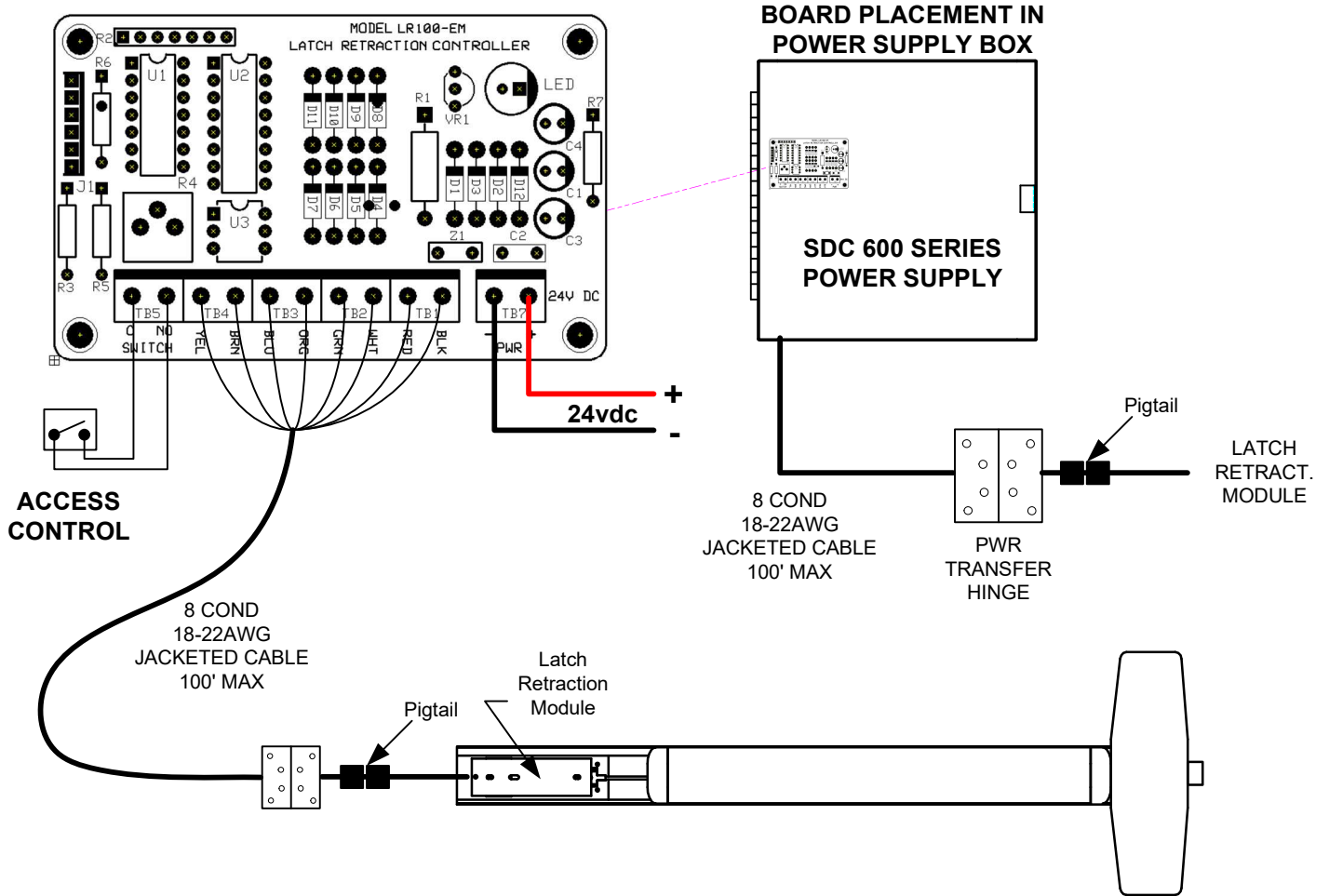

Retrofit Installation Note: 42" or 48" exit devices that have been modified to fit a 36" or smaller opening, may not have the required space to fit the standard E. L. R. assembly. Always verify the distance from the end of the touchpad to the end rail, and if necessary, consult with the factory for appropriate selection.

NOTE Retro-Fitting Vertical Rod Devices:

Before retro-fitting an electric latch assembly into a vertical device, the following must be done to ensure proper alignment. Disconnect the vertical rods from the device. Install the electric latch assembly as shown above. Once the ELR is properly installed energize it so that the push pad is dogged down, by doing so it will allow for proper alignment for the vertical rods. Finally reconnect the vertical rods to the device and make the proper adjustments.