

APPLICATION	Intended Use: Program Material: Installation:	Mass notification and emergency communications Signal tones and voice Fits into a 2' x 2' or 2' x 4' ceiling tile grid
CERTIFICATION	UL Listed 1480A (Type G): UL Listed 2043: City of Chicago Approved	When installed per supplied installation instructions and requirements of NEC/AHJ Suitable for use in air-handling spaces. Material and construction permits use where ceiling plenum is part of the air handling system

INSTALLATION INSTRUCTIONS

- Cut ceiling tile as required:
2' x 2' tile – No cutting required.
2' x 4' tile – Cut tile in half on 4' side.
- Required only if using conduit clamp fitting **other than what is provided with product**.
 - Loosen, but do not remove screws** on cover plate; slide plate to large keyhole position and lift plate from assembly.
 - Remove cable/conduit clamp fitting from cover plate;** Install UL Listed metallic enclosure entry fitting for plenum cable or flex whip.
 - Feed supply cable through whip to speaker wires.** Make connections per wiring diagram; Use appropriate connectors to meet any required codes.
 - Replace cover plate and tighten cover plate screws. When cover plate is secured, all connections/splices must be inside of the enclosure.
- Make the respective field wiring connections for an amplifier with either 8 Ohm or 70V output.
 - Connect the common (black) wire from the SYSTEM 19 to the existing field wiring common wire.
 - Connect the positive (red) wire from the SYSTEM 19 to the existing field wiring positive wire. All connections/splices must be inside of the enclosure.
 - Using the rotary selector, select the desired speaker tap power level.
 - Tighten screws on cable clamp.

IMPORTANT:

- Verify all code requirements with local AHJ before selecting connection method.
- Using code compliant connectors for all field wiring.

IMPORTANT:

- Do not mix 8 Ohm speakers with 70V speakers on the same amplifier output line.

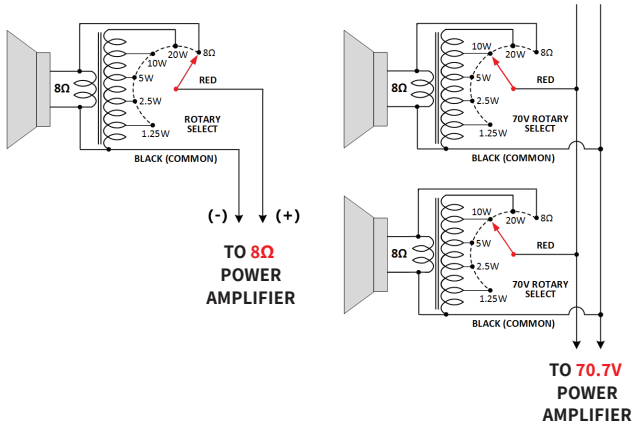
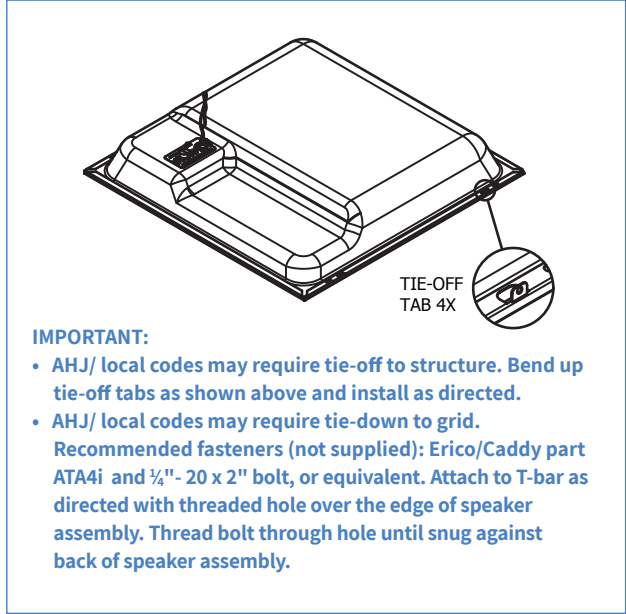

- Place remaining ceiling tile into grid opening as required.