



**FEDERAL SIGNAL**

Safety and Security Systems / **Industrial**

*Advancing security and well being*

## **Model 154XST Series Strobe Light for Use in Hazardous Conditions**



---

### ***Installation and Maintenance Manual***

2561762C  
REV. C 312  
Printed in U.S.A.



**Warranty** – Seller warrants all goods for five years on parts and 2-1/2 years on labor, under the following conditions and exceptions: Seller warrants that all goods of Seller's manufacture will conform to any descriptions thereof for specifications which are expressly made a part of this sales contract and at the time of sale by Seller such goods shall be commercially free from defects in material or workmanship. Seller reserves the right at the Seller's discretion to "Repair and Return" or "Replace" any item deemed defective during the warranty period. This warranty does not cover travel expenses, the cost of specialized equipment for gaining access to the product, or labor charges for removal and reinstallation of the product. This warranty shall be ineffective and shall not apply to goods that have been subjected to misuse, neglect, accident, damage, improper maintenance, or to goods altered or repaired by anyone other than Seller or its authorized representative, or if five years have elapsed from the date of shipment of the goods by Seller with the following exceptions: lamps and strobe tubes are not covered under this warranty. Outdoor warning sirens and controllers manufactured by Federal Warning Systems are warranted for two years on parts and one year on labor. No agent, employee, representative or distributor of Seller has any authority to bind the Seller to any representation, affirmation, or warranty concerning the goods and any such representation, affirmation or warranty shall not be deemed to have become a part of the basics of the sales contract and shall be unenforceable. THE FOREGOING WARRANTIES ARE EXCLUSIVE AND IN LIEU OF ALL OTHER WARRANTIES OR MERCHANTABILITY, FITNESS FOR PURPOSE AND OF ANY OTHER TYPE, WHETHER EXPRESS OR IMPLIED. These warranties shall not apply unless Seller shall be given reasonable opportunity to investigate all claims for allegedly defective goods. Upon Seller's instruction a sample only of allegedly defective goods shall be returned to Seller for its inspection and approval. The basis of all claims for alleged defects in the goods not discoverable upon reasonable inspection thereof pursuant to paragraph 8 hereof must be fully explained in writing and received by Seller within thirty days after Buyer learns of the defect or such claim shall be deemed waived.



Industrial Systems

2645 Federal Signal Drive • University Park, IL 60484-3167

Tel: 708-534-4756 • Fax: 708-534-4852

Email: [elp@federalsignal.com](mailto:elp@federalsignal.com) • [www.federalsignal-indust.com](http://www.federalsignal-indust.com)

---

# Contents

<b>Safety Messages to Installers .....</b>	<b>5</b>
<b>An Overview of the 154XST Series .....</b>	<b>6</b>
<b>Unpacking the Light.....</b>	<b>7</b>
<b>Pipe-Mounting the Beacon (154XST).....</b>	<b>8</b>
<b>Surface-Mounting the Beacon (154XST-S).....</b>	<b>10</b>
<b>Wiring the Beacon.....</b>	<b>11</b>
<b>Safety Message to Maintenance Personnel.....</b>	<b>13</b>
<b>Servicing the Beacon.....</b>	<b>14</b>
Replacing the Flash Tube.....	15
Replacing the Printed Circuit Board (PCB).....	16
<b>Cleaning the Fixture.....</b>	<b>17</b>
<b>Lubricating the Threaded Joint.....</b>	<b>17</b>
<b>Getting Service, Assistance, and Parts.....</b>	<b>17</b>
Repair Service .....	17
Technical Assistance.....	18
Accessories and Replacement Parts.....	18
<b>Returning the Product for Credit .....</b>	<b>19</b>

**Tables**

**Table 1** Specifications ..... 7  
**Table 2** Flash rate and candelas ..... 7  
**Table 3** Hazardous Location Rating ..... 8  
**Table 4** Replacement parts ..... 18  
**Table 5** Accessory ..... 19

**Figures**

**Figure 1** Pipe-mounted beacon ..... 9  
**Figure 2** Surface-mounted beacon ..... 10  
**Figure 3** Cross section of beacon ..... 12  
**Figure 4** Flash tube darkening ..... 15

## **Safety Messages to Installers**

### **⚠ WARNING**

It is important to follow all instructions shipped with this product. This device is to be installed by a trained electrician who is thoroughly familiar with the National Electrical Code and/or Canadian Electrical Code and will follow the NEC and/or CEC Guidelines as well as all local codes. This beacon should be considered a part of the warning system and not the entire warning system.

The selection of the mounting location for the beacon, its controls and the routing of the wiring are to be accomplished under the direction of the facilities engineer and the safety engineer. In addition, listed below are some other important safety instructions and precautions you should follow:

- Read and understand all instructions before installing or operating this beacon.
- Never alter the unit in any manner. Safety in hazardous locations may be endangered if additional openings or other alterations are made to units specifically designed for use in these locations.
- Do not connect this light to the system when power is on.
- After installation, ensure that the set screw is properly tightened and that threaded joints are fully engaged.
- After installation, test the light system to ensure that it is operating properly.
- After testing is complete, provide a copy of this instruction sheet to all operating personnel.
- Establish a procedure to routinely check the light installation for integrity and proper operation

Failure to follow all safety precautions and instructions may result in property damage, serious injury, or death.

## **An Overview of the 154XST Series**

Federal Signal's Model 154XST hazardous location strobe light provides 80 high-intensity flashes per minute. This warning light is available in 24 Vdc with a 4-wire supervisable power circuit for fire alarm and suppression supervised control panels.

The Model 154XST strobe light is UL and cUL Listed and CSA Certified for Class I, Division 2, Groups A, B, C and D; Class II, Division 1, Groups E, F and G; and Class III.

The 154XST meets Type 4X water-tight, dust-tight, and corrosion-resistant requirements; constructed to IP66. This hazardous location warning light has an aluminum base, coated for corrosion-resistance that is ready for mounting on a 3/4-inch NPT pipe. The included dome guard fits over the glass dome to protect it against accidental collision with moving equipment, such as forklifts. An optional wall bracket is also available.

The 154XST has an effective candela (ECP) of 165 and a 520,000 peak candela. It is available in six dome colors, including amber, blue, clear, green, and red (magenta upon request).

Federal Signal's rugged 154XST strobe warning light is specifically designed for hazardous locations or corrosive environments where a very bright visual signal is required. This warning light can be used for plant evacuation or other communication needs.

Models are available for pipe mounting (154XST) or surface mounting (154XST-S).

**NOTE:** The 154XST can be mounted to a Federal Signal Model LHWB bracket. If installed in this way, the entire assembled device is suitable only for Class I, Div. 2, Groups A, B, C, and D; Class II, Div. 2, Groups F and G; Class III locations.

## Unpacking the Light

**⚠ WARNING**

**EXPLOSION HAZARD—Damaged domes can lead to explosions that could result in serious injury or death.**

After unpacking the beacon, examine it for damage that may have occurred in transit. If the beacon has been damaged, do not attempt to install or operate it. File a claim immediately with the carrier, stating the extent of the damage. Carefully check all envelopes, shipping labels, and tags before removing or discarding them. Disposal of all shipping materials must be carried out in accordance with national and local codes and standards. If any parts are missing, please call Federal Signal Customer Support at 708-534-4756.

**Table 1** Specifications

Lamp Life:	10,000 hours
Light Source:	Strobe tube
Voltage:	24 Vdc
Current Draw:	0.60 A
Operating Temperature:	−67 °F to 150 °F (−55 °C to 66 °C)
Net Weight:	3.8 lb (1.7 kg)
Shipping Weight:	4.5 lb (2.0 kg)
Height:	9.25 in (234.95 mm)
Diameter:	5.5 in (139.7 mm)

**Table 2** Flash rate and candelas

Model	Flash Rate per Minute	Candela	
		Peak <sup>1</sup>	ECP <sup>2</sup>
154XST(-S)	80	520,000	165

<sup>1</sup>Peak candela is the maximum light intensity generated by a flashing light during its light phase.

<sup>2</sup>ECP (Effective Candela) is the intensity that would appear to an observer if the light were burning steadily.

**Table 3** Hazardous Location Rating

<b>Hazardous Environment</b>	<b>Max. Temp./UL Temp. Code at 40 °C Ambient</b>	<b>Max. Temp./UL Temp. Code at 66 °C Ambient</b>
Class I, Div 2	275 °C/T2	301 °C/T1
Class II, Groups E, F & G	100 °C/T5	100 °C/T5
Class III	100 °C/T5	100 °C/T5

To reduce the risk of fire or explosion, do not install the beacon in a hazardous location if the operating temperature exceeds the ignition temperature of hazardous atmosphere.

Before proceeding, use Table 3 above as a guide and determine that the unit’s operating temperature DOES NOT exceed the hazardous atmosphere’s ignition temperature.

For marine applications, all wiring including supply wire must be stranded wire and meet the USCG (CFR46) Sections (110-113).

### **Pipe-Mounting the Beacon (154XST)**



***EXPLOSION HAZARD—To reduce the risk of fire or explosion, do not install the beacon in a hazardous location if the operating temperature exceeds the hazardous atmosphere’s ignition temperature. Before proceeding, consult the product nameplate and determine the operating temperature of the beacon.***

To comply with NEC Section 300-14, which requires a minimum of 6 inches (15.25 cm) of free conductor at a junction, when mounting the Model 154XST, the mounting pipe used to join the unit to a splice box should be no longer than 10 inches (25.4 cm).

**NOTE:** In high-humidity environments when units are mounted dome down, condensation may occur in the conduit system. Use properly rated conduit seals/drains to prevent moisture from entering the fixture.



The Model 154XST has provisions for mounting a 3/4-inch pipe and can be mounted in any position.

To pipe-mount the beacon:

1. Before mounting the beacon, ensure that the mating threads are clean.
2. To prevent the ingress of water and dust, apply conductive sealant to the conduit threads prior to mounting. If non-conductive sealant is used, the enclosure must be earthed via the provided internal grounding wire/grounding screw to ensure proper grounding continuity (Figure 3 on page 12).
3. Thread the fixture onto the 3/4-inch pipe and secure it with the set screw.

**Figure 1** Pipe-mounted beacon

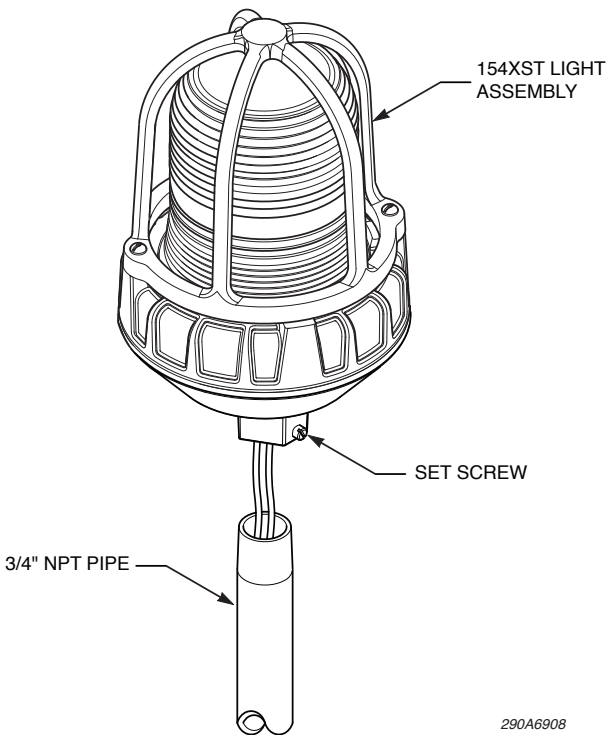

290A6908

## **Surface-Mounting the Beacon (154XST-S)**

To surface mount the beacon:

1. Use the mounting base as a template to mark the location of the two mounting holes.
2. Drill a 9/32 inch (7.143 mm) hole at each mark.
3. Secure the beacon to the mounting surface with installer supplied hardware.

**Figure 2** Surface-mounted beacon

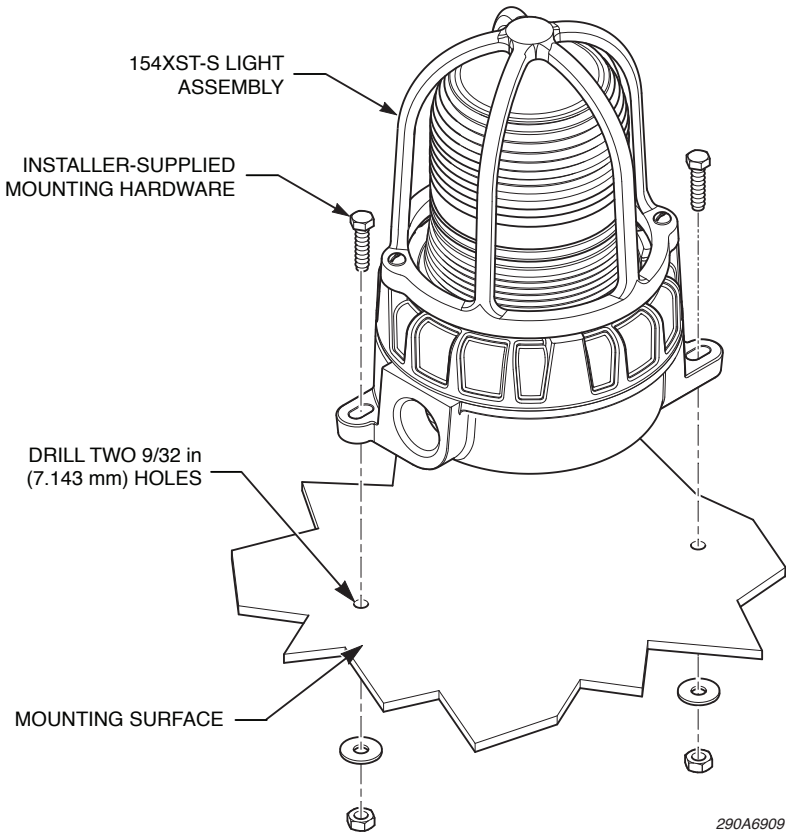

## **Wiring the Beacon**

The Model 154XST Series LED Beacon should be installed per the NEC or CEC, STATE and LOCAL CODES. Alternate installation locations and/or orientations should only be performed with the approval of the authority having jurisdiction. In addition, the unit can be mounted using an optional ceiling mount or optional wall mount.

**⚠ WARNING**

***SHOCK HAZARD—To avoid electrical shock hazards, do not connect wires while power is applied.***

**⚠ WARNING**

***SHOCK/FIRE HAZARD—This is a four-wire device, and when installed, all four wires must be terminated. Failure to terminate both red and black wires will result in a shock or fire hazard.***

**⚠ WARNING**

***EXPLOSION HAZARD—Do not disconnect the beacon while the circuit is live or unless the area is known to be free of ignitable concentrations. Keep the beacon tightly closed when in operation.***

**NOTICE**

***REVERSE POLARITY/MISWIRING—The 154XST is not polarity sensitive, but MAY BE DAMAGED by incorrect electrical hookup. Damage will result if the voltage rating of the particular model is exceeded.***

**NOTE:** Wiring must comply with the National Electrical Code or Canadian Electrical Code and the local authority having jurisdiction.

## Installation and Service Instructions

The beacon has two 24-inch leads, one black and one red. To wire the beacon:

1. Ensure that power is off.
2. Remove the threaded dome assembly by twisting it counterclockwise.

**Figure 3** Cross section of beacon

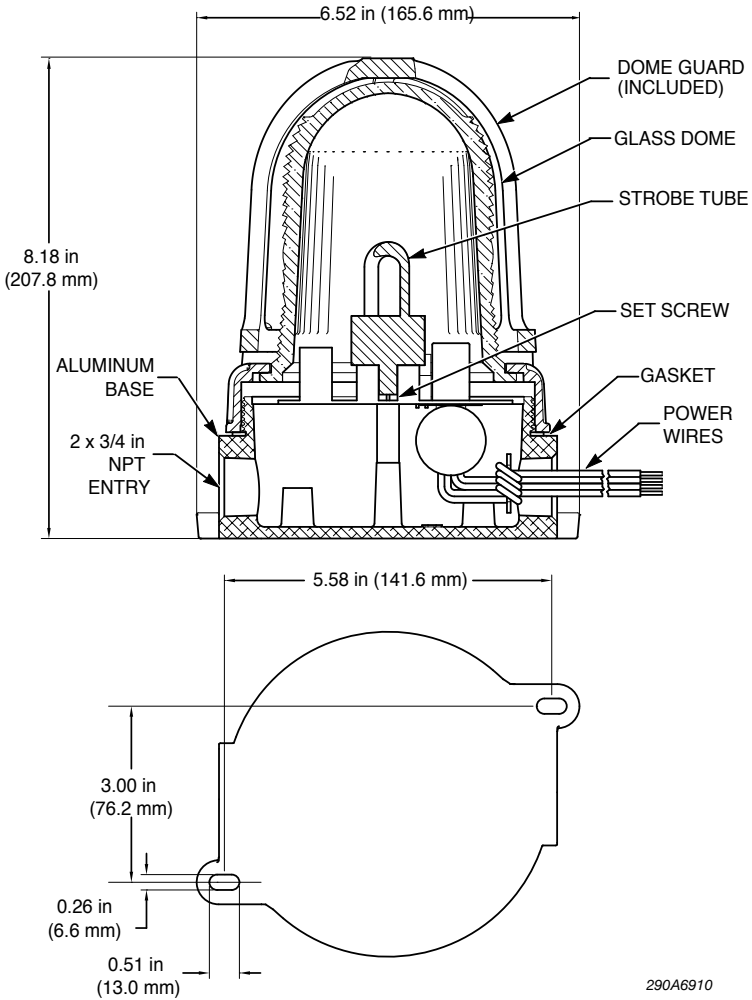

3. Connect the red (+) lead to the positive side of the power source and the black (–) lead to the negative side of power source.
4. If required, the green screw in the housing is provided for connection to an earth ground. To gain access to the screw, remove the power supply assembly.
5. Secure the dome to the base of the beacon.
6. Connect power to the beacon and test it for proper operation.

## **Safety Message to Maintenance Personnel**

Listed below are some important safety instructions and precautions you should follow:

- Read and understand all instructions before operating this system.
- Any maintenance to the light system must be done with power turned off.
- Any maintenance to the light system must be performed by a trained electrician who is thoroughly familiar with all applicable national and local codes in the country of use.
- Do not connect this beacon to the system when power is on.
- Do not disconnect the beacon while the circuit is live or unless the area is known to be free of ignitable concentrations. Keep the beacon tightly closed when in operation.
- Never alter the unit in any manner. Safety of the unit may be affected if additional openings or other alterations are made to the internal components or housing.
- The nameplate should NOT be obscured, as it contains cautionary and/or other information of importance to maintenance personnel. Ensure the nameplate remains readable if the housing exterior is painted.

## ***Installation and Service Instructions***

---

- If the dome is damaged in any way, it **MUST** be replaced.
- After performing any maintenance, test the light system to ensure that it is operating properly.

Failure to follow all safety precautions and instructions may result in property damage, serious injury, or death.

## **Servicing the Beacon**

### **⚠ WARNING**

***EXPLOSION HAZARD—To prevent ignition of hazardous atmospheres, disconnect the fixture from the supply circuit before opening it.***

### **⚠ WARNING**

***EXPLOSION HAZARD—Do not disconnect the beacon while circuit is live or unless the area is known to be free of ignitable concentrations. Keep the beacon tightly closed when in operation.***

### **⚠ WARNING**

***EXPLOSION HAZARD—To maintain the vapor-tight enclosure, do not damage the globe or threads while disassembling or reassembling the unit. Lubricated threaded joints exposed for long periods of time may attract small particles of dirt or other foreign materials. Housing and cover joints should be reassembled immediately, with all the threads fully engaged.***

### **⚠ WARNING**

***SHOCK HAZARD—High voltages are present inside the light assembly. Wait at least 5 minutes after shutting off the power before servicing this unit.***

Establishing a regular maintenance and inspection schedule extends the life of the Model 154XST and ensures safety. For service, support, or replacement parts, see pages 17 through 19.

## **Replacing the Flash Tube**

As strobe lights are used, the flash tubes begin to darken, causing the light output to decrease. This darkening is characteristic of flash tubes. Darkening will begin near the base of the tube and progress upward. Also, as flash tubes age, they may have a tendency to misfire (not fire periodically).

After extended operation, occasionally check for flash tube degradation. Should the flash tube misfire, have a noticeable decrease in light output, glow continuously or darken to a point beyond that shown in Figure 4, it should be replaced.

**Figure 4** Flash tube darkening

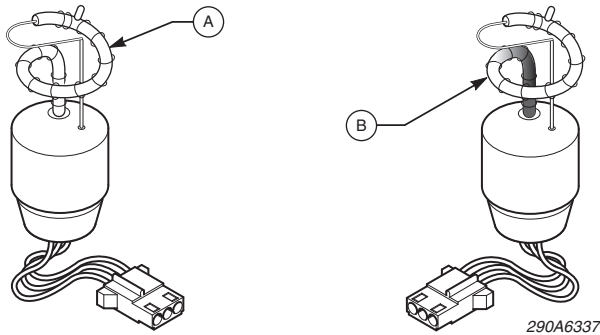

To replace the flash tube:

1. Disconnect the power to the beacon and wait at least 5 minutes to allow all capacitors to discharge.
2. Remove the threaded dome assembly by twisting it counterclockwise.
3. With the dome removed, gently pull the flash tube from its socket. A rocking motion is most helpful when installing or removing the tube.
4. Replace the flash tube. Ensure that the replacement tube is fully seated in the socket.

5. Replace the globe assembly. Ensure that the globe assembly is seated securely against the gasket.
6. Test the beacon for proper operation.

***Replacing the Printed Circuit Board (PCB)***

To replace the PCB:

1. Disconnect the power to the beacon and wait at least 5 minutes to allow all capacitors to discharge.
2. Remove the threaded dome assembly by twisting it counterclockwise.
3. Remove and retain the screw that secures the circuit board to the housing.
4. Disconnect power to the PCB:
  - a) To replace a Series A1, disconnect the two supply wires from the old circuit board and connect them to the mating side of the supplied adapter assembly. Connect the other side of the adapter assembly to the new circuit board.
  - b) To replace a Series A2 circuit board, disconnect the power connector from the old circuit board and connect it to the connector on the new circuit board.

**NOTE:** Ensure that the connector is fully seated on the circuit board connectors.

5. Secure the new circuit board to the housing with the screw removed in step 2.
6. Install the new flash tube in the socket. Ensure that the flash tube is fully seated in the socket.
7. Replace the globe assembly. Ensure that the globe assembly is seated securely against the gasket.



8. Test the light for proper operation.

## **Cleaning the Fixture**

### **⚠ WARNING**

***EXPLOSION HAZARD—Never use an abrasive material or file to remove corrosive materials from threaded surfaces. In extremely corrosive locations, equipment should be periodically inspected to guard against unusual deterioration and possible porosity, since this may weaken the enclosure structurally.***

Maintenance procedures sometimes require fixtures to be hosed down for good housekeeping. The circuit should be turned off prior to hosing down the fixture.

The fixture should be cleaned periodically to maintain maximum light output. Only mild, non-abrasive cleaning agents should be used. The glass globe should be regularly inspected for scratches and chips, and if damaged, **MUST** be replaced.

## **Lubricating the Threaded Joint**

The threaded joint on the cover should be kept well lubricated with a corrosion inhibiting grease such a petrolatum or soap-thickened mineral oil. If corrosive materials have accumulated on the threaded joints and cannot be removed with solvents, the parts should be discarded and replaced.

## **Getting Service, Assistance, and Parts**

Please call the phone numbers listed below. For instruction manuals and information about related products, please go to <http://www.federal-signal-indust.com>.

### ***Repair Service***

Products returned for repair require a Return Authorization form. To obtain service for the product, please contact the Federal Signal Service Department at 708-534-4858.

**Technical Assistance**

For technical assistance, please call Technical Support at 708-534-3424, extension 5823.

**Accessories and Replacement Parts**



**EXPLOSION HAZARD—Substitution of components may impair suitability for Class I, Division 2.**

Typical spare parts are listed in Table 4. Due to certification, certain component parts are not available for field replacement. Units with this type of damage must be either replaced entirely or returned to Federal Signal for service. To order accessories and replacement parts, please call Federal Signal Customer Support at 708-534-4756.

**Table 4** Replacement parts

<b>Description</b>	<b>Part Number</b>
Dome Assy., Red	K8449078
Dome Assy., Amber	K8449078-01
Dome Assy., Clear	K8449078-04
Dome Assy., Blue	K8449078-06
Dome Assy., Green	K8449078-07
Dome Assy., Magenta	K8449078-05
Gasket	K8449080
Grease, 8 oz Tube	KR81-05-01
Dome Guard	K8449090
Power Supply Assy., 12-24 Vdc	K2001173
Power Supply Assy., 120 Vac	K2001071
Power Supply Assy., 240 Vac	K2001071-01
Flash Tube	K149122

**Table 5** Accessory

<b>Description</b>	<b>Part Number</b>
Hazardous Location Wall-Mount Bracket	LHWB*

*\* Cannot be used in Class II, Division 1 applications. NEMA 4X and IP66 rated when used with the appropriate conduit fittings.*

## **Returning the Product for Credit**

Product returns for credit require a return authorization from your local distributor prior to returning the product to Federal Signal. Please contact your distributor for assistance.

A product is qualified to be returned for credit when the following conditions are met:

- Product is resalable and in the original cartons
- Product has not been previously installed
- Product is the current revision
- Product has not been previously repaired
- Product is a standard product
- Product is not a service part

All returns are subject to a re-stock fee.

Defective products that are returned within the warranty period will be repaired or replaced at Federal Signal's sole discretion. Defective products do not include those products with lamp failure.

Circumstances other than those listed above will be addressed on a case-by-case basis.



Industrial Systems

2645 Federal Signal Drive • University Park, IL 60484-3167

Tel: 708-534-4756 • Fax: 708-534-4852

Email: [elp@federalsignal.com](mailto:elp@federalsignal.com) • [www.federalsignal-indust.com](http://www.federalsignal-indust.com)

© 2012 Federal Signal Corporation. All rights reserved.