

Features

- Single module with dual contact monitoring inputs
- Two (2) Class B or one (1) Class A monitoring inputs
- Two (2) Form C relay contacts
- SLC Class A, Class X & Class B
- Mounts in a standard 4" or double gang box
- Wiring terminals accessible when mounted in box
- All wiring terminals accept 22 to 12 AWG
- Product includes a 5 year warranty
- UUKL Listed for Smoke Control

NOTE: This addressable module does not support 2-wire smoke detectors.



Description

The PAD100-TRTI uses one (1) SLC loop address when monitoring two (2) Class B circuits or one (1) Class A circuit. The PAD100-TRTI also provides two (2) Form C relay contacts. The module mounts on either a 4" square or double gang box. The module is capable of monitoring two (2) separate Class B circuits making it ideal for monitoring sprinkler waterflow and valve tamper switches when they are located in the same proximity. The PAD100-TRTI includes one red LED to indicate the module's status. In normal condition, the LED flashes when the device is being polled by the control panel. When an input is activated, the LED will flash at a fast rate.

Application

The PAD100-TRTI is compatible with Potter's IPA and AFC/ARC series addressable fire alarm control panels. The PAD100-TRTI is an interface module used to monitor dry contact devices such as sprinkler waterflow, valve tamper switches, or conventional pull stations. The module is capable of monitoring two separate Class B or one Class A circuits. The PAD100-TRTI also provides two (2) form C relay contacts.

Setting the Address

Each addressable SLC device must be assigned an address. The address is set using the DIP switch located on the PAD100-TRTI. The PAD100-TRTI is assigned a single device address, each input and relay is identified as a sub-point of that single module address. For example, if the address number is assigned as "8", the RLY1 relay will be "8.1", the RLY2 relay will be "8.2", the B1 input will be "8.3" and the B2 input will be "8.4".

Before connecting a device to the SLC loop, take the following precautions to prevent potential damage to the panel or device:

1. Power to the device is removed.
2. Field wiring is correctly installed.
3. Field wiring has no open or short circuits.

Technical Specifications

Operating Voltage	24.0V
Max SLC Standby Current	240 μ A
Max SLC Alarm Current	240 μ A
Relay Contacts	2A @30VDC, 0.5A @125VAC
Max Wiring Resistance of IDC	100 Ω
Max Wiring Capacitance of IDC	1 μ F
EOL Resistor	5.1K Ω
Operating Temperature Range	32 to 120°F (0 to 49°C)
Operating Humidity Range	0 to 93% (non-condensing)
Max no. of Module Per Loop	127 units
Dimensions	4.17" (106mm)L \times 4.17" (106mm)W \times 1.14" (29mm)D
Mounting Options	Standard 4" Square or Double Gang Box
Shipping Weight	0.6 lbs

Installation Using Compatible Electrical Box

Fig 1

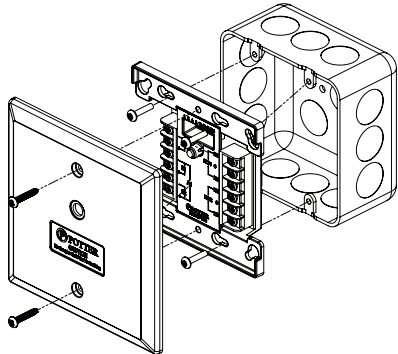

Wiring Diagrams

PAD100-TRTI With One Class A Circuit

Fig 2

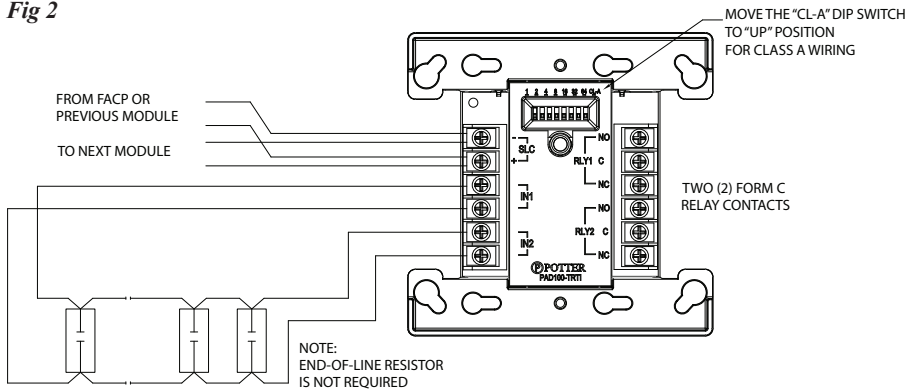

PAD100-TRTI With Two Class B Circuits

Fig 3

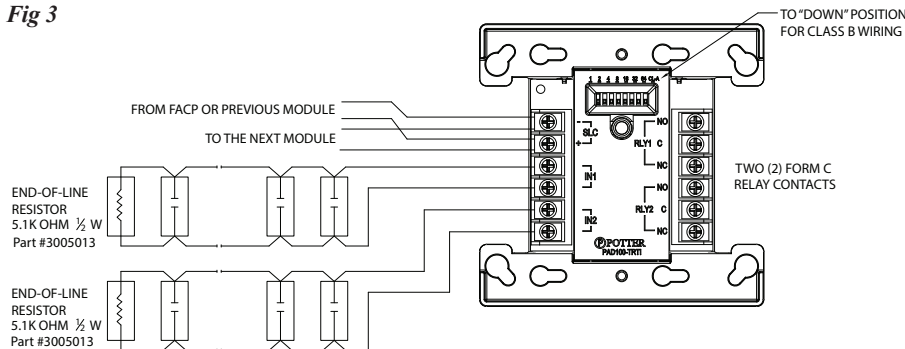

NOTICE

It is possible that the internal relay in the PAD100-TRTI may be shipped in the non-normal / activated state. To ensure that the internal relay is set to the normal state, connect the module to the SLC loop and reset the control panel before terminating the wiring to the modules output.

Ordering Information

Model	Description	Stock No.
PAD100-TRTI	Two Relay Two Input Input Module	3992701