

## INSTALLATION MANUAL: IDC-6 INITIATING DEVICE CIRCUIT EXPANDER

### NOTICE TO THE INSTALLER

This manual provides an overview and the installation instructions for the IDC-6 module. All terminals are power limited and should be wired in accordance with the requirements of NFPA 70 (NEC) and NFPA 72 (National Fire Alarm Code). Failure to follow the wiring diagrams in the following pages will cause the system to not operate as intended. For further information, refer to the control panel installation instructions. The module shall only be installed with listed control panels. Refer to the control panel installation manual for proper system operation.

### 1. DESCRIPTION

The Initiating Device Circuit Expander (IDC-6) provides an additional 6 inputs per module. The panel supports up to thirty-one (31) IDC-6 modules. The circuits are power-limited and supervised. All inputs are suitable to monitor 2-wire smoke detectors. Smoke detectors shall be installed in compliance with NFPA 72. Inputs can also be used for automatic, manual, waterflow or supervisory service. The IDC-6 communicates via the PLink communication bus. The IDC-6 can be mounted in either the control panel cabinet, the intelligent power supply, AE-2, AE-8 or the AE-14 expander cabinet. Each card is mounted to the exclusive Stacker Bracket for secure and accessible mounting.

### 2. SETTING THE ADDRESS

Each P-Link device has a **five (5) position dip switch** which is used to program the device address ranging from one (1) to thirty-one (31). The table below may be used to set dip switches when addressing any P-Link module:

FIGURE 1. DIP SWITCH SETTINGS TABLE (ADDRESSES 1–31)

	1	2	4	8	16		1	2	4	8	16
1	Gray	White	White	White	White	17	Gray	White	White	White	White
2	White	Gray	White	White	White	18	White	Gray	White	White	White
3	White	White	Gray	White	White	19	White	White	Gray	White	White
4	White	White	White	Gray	White	20	White	White	White	Gray	White
5	White	White	White	White	Gray	21	White	White	White	White	Gray
6	White	White	White	White	White	22	White	White	White	White	White
7	White	White	White	White	White	23	White	White	White	White	White
8	White	White	White	White	White	24	White	White	White	White	White
9	White	White	White	White	White	25	White	White	White	White	White
10	White	White	White	White	White	26	White	White	White	White	White
11	White	White	White	White	White	27	White	White	White	White	White
12	White	White	White	White	White	28	White	White	White	White	White
13	White	White	White	White	White	29	White	White	White	White	White
14	White	White	White	White	White	30	White	White	White	White	White
15	White	White	White	White	White	31	White	White	White	White	White
16	White	White	White	White	White						

**Note:** Each **"gray" box** indicates that the dip switch is **"On,"** and each **"white" box** indicates **"Off."**

The examples shown below illustrate a P-Link's dip switch settings: the 1st example shows a P-Link module *not addressed* where all dip switch settings are in the *default "Off" position*, the 2nd illustrates an *addressed P-Link module* via the dip switch settings.

FIGURE 2. EXAMPLES OF P-LINK MODULE SHOWING DEFAULT DIP SWITCH SETTING (UNADDRESSED) & ADDRESSED



All dip switches are shown in the "Off" position.

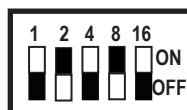

Example shows this P-Link module address = 10. Dip switches #2 & 8 are in the "On" position.

## INSTALLATION MANUAL: IDC-6 INITIATING DEVICE CIRCUIT EXPANDER

Before connecting a device to the RS-485 connection, take the following precautions to prevent potential damage to the RS-485 connection.

- Power to the RS-485 connection is removed.
- Field wiring on module is correctly installed.
- Field wiring has no open or short circuits.

### 3. TECHNICAL SPECIFICATIONS

P-Link Standby Current	20 mA
P-Link Alarm Current	20 mA
IDC PWR Standby Current	30 mA (maximum Standby)
IDC PWR Alarm Current	270 mA (maximum Alarm)
Input Zone Wiring Resistance	100 ohms max
Input Zone Capacitance	1 mF max
Input Zone Short Circuit Current	47 mA
Operating Temperature Range	32° to 120°F (0° to 49° C)
Operating Humidity Range	10%-93% (non-condensing)
Max no. of IDC-6 Expanders	31
Dimensions (WxHxD)	4" x 6" x 1 5/8"

**Note:** IDC PWR can be provided by any fire listed source. Power must be 16 VDC- 33 VDC, and must be power limited.

### 4. INSTALLATION

The IDC-6 is connected to the fire control panels using a 4-wire RS-485 connection. The connection is power limited and supervised. The IDC-6 must be mounted in either a compatible fire alarm panel, the PSN-1000, or within 20 feet of the panel or power supply using the AE-2, AE-8, or the AD-14 expander cabinet. Each card is mounted to the exclusive Stacker Bracket for secure and accessible mounting.

The wiring diagrams shown below illustrate how to wire a IDC-6 as Class B and Class A.

**FIGURE 3. CLASS B P-LINK AND IDC POWER WIRING**

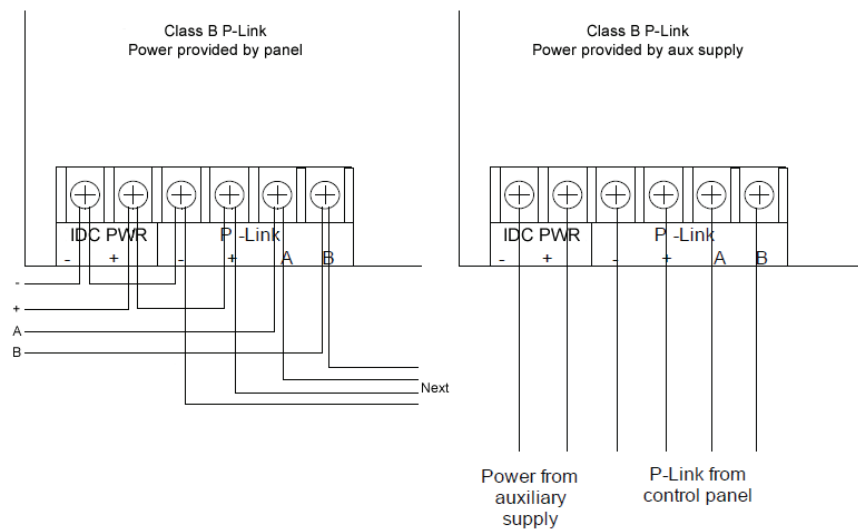

# INSTALLATION MANUAL: IDC-6 INITIATING DEVICE CIRCUIT EXPANDER

**FIGURE 4. CLASS A P-LINK AND IDC POWER WIRING**

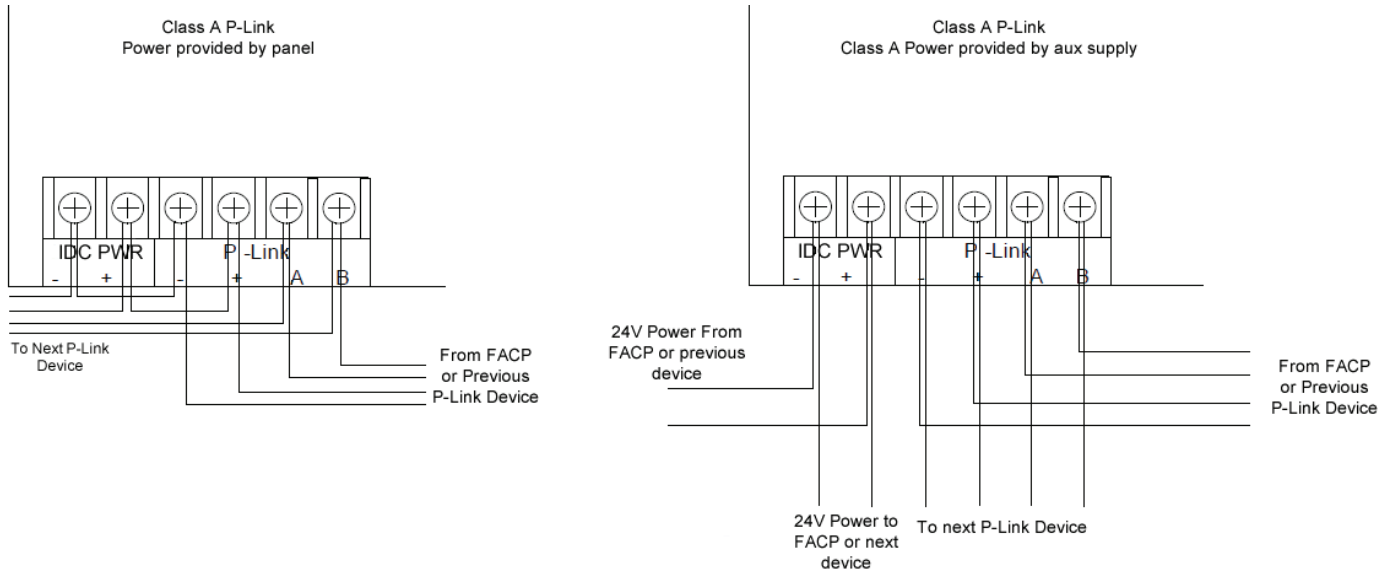

**FIGURE 5. EXAMPLE OF WIRING A IDC-6 MODULE CLASS A (LEFT) OR CLASS B (RIGHT)**

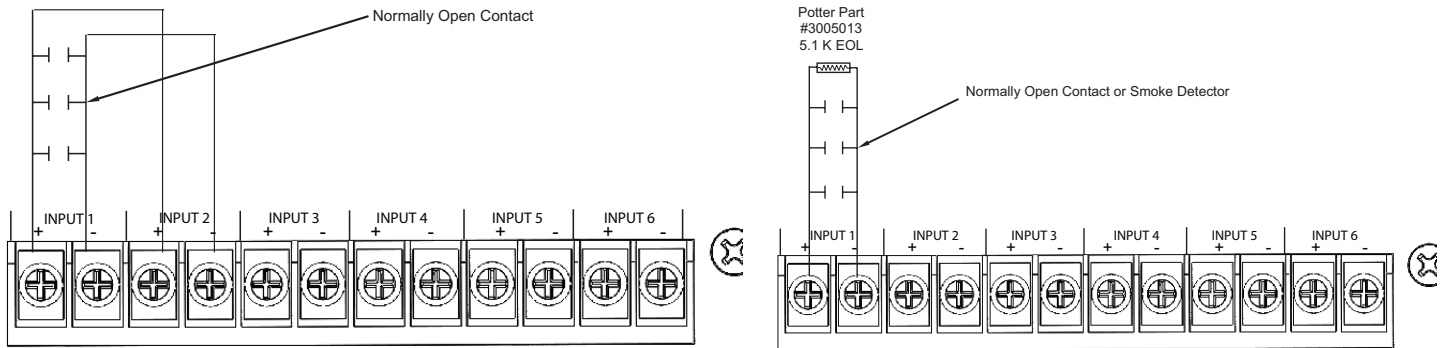

**NOTES:**

- Input 1 - Input 6 are power limited, 24 VDC inputs
- RS-485 wiring style supports class A and class B.
- RS-485 is power limited.
- Wiring for terminals (A, B) and (+, -) are supervised.
- All wiring is between #12 (max.) And #18 (min.).
- Wire preparation – strip all wires 1/4 inch from their edges as shown here:
  - Stripping too much insulation may cause a ground fault.
  - Stripping too little may cause a poor connection and subsequently an open circuit.



These instructions do not purport to cover all the details or variations in the equipment described, nor provide for every possible contingency to be met in connection with installation, operation and maintenance.

Specifications subject to change without prior notification.

For Technical Assistance contact Potter Electric Signal Company at 866-956-1211.

Actual performance is based on proper application of the product by a qualified professional.

Should further information be desired or should particular problems arise, which are not covered sufficiently for the purchaser's purpose, the matter should be referred to a distributor in your region.

## INSTALLATION MANUAL: IDC-6 INITIATING DEVICE CIRCUIT EXPANDER

<b>TABLE 1: COMPATIBLE CONVENTIONAL SMOKE DETECTORS &amp; BASES</b>			
<b>DETECTOR MODEL</b>	<b>Identifier</b>	<b>Base Model</b>	<b>Identifier</b>
<b>SYSTEM SENSOR (BRK) (MAX. NO. OF DETECTORS PER ZONE IS 20)</b>			
1400	A	N/A	N/A
2400	A	N/A	N/A
2400TH	A	N/A	N/A
2W-B	A	N/A	N/A
2WT-B	A	N/A	N/A
<b>DETECTION SYSTEM (MAX. NO. OF DETECTORS PER ZONE IS 25)</b>			
DS250	A	MB2W/MB2WL	A
DS250TH	A	MB2W/MB2WL	A
<b>ESL (MAX. NO. OF DETECTORS PER ZONE IS 25)</b>			
611U	S10	601U	S00
611UD	S10	601U	S00
611UT	S10	601U	S00
612U	S10	601U	S00
612UD	S10	601U	S00
613U5	S10	601U	S00
611UD	S10	609U10	S00
612UD	S10	609U10	S00
425C	S10	N/A	N/A
425CT	S10	N/A	N/A
<b>HOCHIKI (MAX. NO. OF DETECTORS PER ZONE IS 25)</b>			
SLR-24	HD-3	HSC-221R	HB-71
		HSB-221	HB-54
		HSB-221N	HB-54
		NS6-221	
		NS4-221	
SLR-24H	HD-3	NS6-220	HB-3
		HSC-221R	HB-71
		HSB-221	HB-54
		HSB-221N	HB-54
		NS6-221	
SIJ-24	HD-3	NS4-221	
		HSC-221R	HB-71
		HSB-221	HB-54
		HSB-221N	HB-54
		NS6-221	
SOC-24V	HD-3	NS4-221	
		HSB-221	HB-54
		NS6-221	HB-4
		NS4-221	HB-4
		NS6-220	HB-3
SOC-24VN	HD-3	HSB-221	HB-54
		NS6-221	HB-4
		NS4-221	HB-4
		NS6-220	HB-3
		NS4-221	HB-3
<b>FENWAL (MAX. NO. OF DETECTORS PER ZONE IS 25)</b>			
CPD-7051	151FE1	2-WIRE	FE51A
PSD-7155	P55FE1	2WRLT	FE52A
PSD-7156	P56FE1	2WRB	FE55A
<small>ALL OF THE ABOVE FENWAL DETECTORS AND BASES CAN BE USED IN ANY COMBINATION.                      RETROFIT BASE ADAPTOR 70-501000-003, IDENTIFIER MAFE1 (FOR SERIES 70-201000 BASES, MODELS -001,-002,-003 AND -005).                      DUCT HOUSING WITH DETECTOR BASE DN-51, IDENTIFIER DH22FE5 (FOR CPD-7051 AND PSD-7155 DETECTORS ONLY).</small>			

## INSTALLATION MANUAL: IDC-6 INITIATING DEVICE CIRCUIT EXPANDER

DETECTOR MODEL	Identifier	Base Model	Identifier
<b>POTTER (MAX. NO. OF DETECTORS PER ZONE IS 25)</b>			
PS-24	HD-3 (HOCHIKI)	SB-46	HB-71 (HOCHIKI)
			HB-54 (HOCHIKI)
		SB-93	HB-3 (HOCHIKI)
PS-24H	HD-3 (HOCHIKI)	SB-46	HB-71 (HOCHIKI)
			HB-54 (HOCHIKI)
IS-24	HD-3 (HOCHIKI)	SB-46	HB-71 (HOCHIKI)
			HB-54 (HOCHIKI)
CPS-24	HD-3 (HOCHIKI)	SB-46	HB-4 (HOCHIKI)
		SB-93	HB-3 (HOCHIKI)
CPS-24N	HD-3 (HOCHIKI)	SB-46	HB-4 (HOCHIKI)
		SB-93	HB-3 (HOCHIKI)
<b>NOTE:</b> IF USING A MIX OF SYSTEM SENSOR AND OTHER SMOKE DETECTORS, A MAXIMUM OF 20 DETECTORS SHALL BE PERMITTED.			