

# EXPLOSION PROOF VIBRATING HORN



## Model FHEX

The Federal Signal Model FHEX Explosion Proof Vibrating Horn produces a loud and distinctive tone by the electro-mechanical vibration of a diaphragm. This horn is designed for use in alarm notification systems and is compatible with fire alarm and suppression supervised control panels and power boosters.

The Model FHEX operates on 24VDC and produces a very loud 100dB at ten feet (110dB at one meter).

The FHEX is UL Listed for Class I, Division 1, Groups C & D; Class II, Division 1, Groups E, F, and G; and Class III.

The FHEX is housed in a heavy duty, copper free cast aluminum housing tapped for 3/4" conduit. The housing is sealed with red powder coat paint and utilizes a stainless steel diaphragm for long life.

## DESIGNED FOR USE IN EXPLOSION-PROOF ATMOSPHERES

- Available in 24VDC
- Cast aluminum housings
- Produces 100dB @ 10' (110dB @ 1m)
- NEMA 4X, IP66 enclosure
- UL and cUL Listed, CSA Certified
- Supervisory diode and four wires

Model	Voltage	Operating Current	Decibels @	
			10'	1m
FHEX	24VDC	1.20 amps	100	110



**FEDERAL SIGNAL**  
Electrical Products

AUDIBLE SIGNALING DEVICE (FHEX)

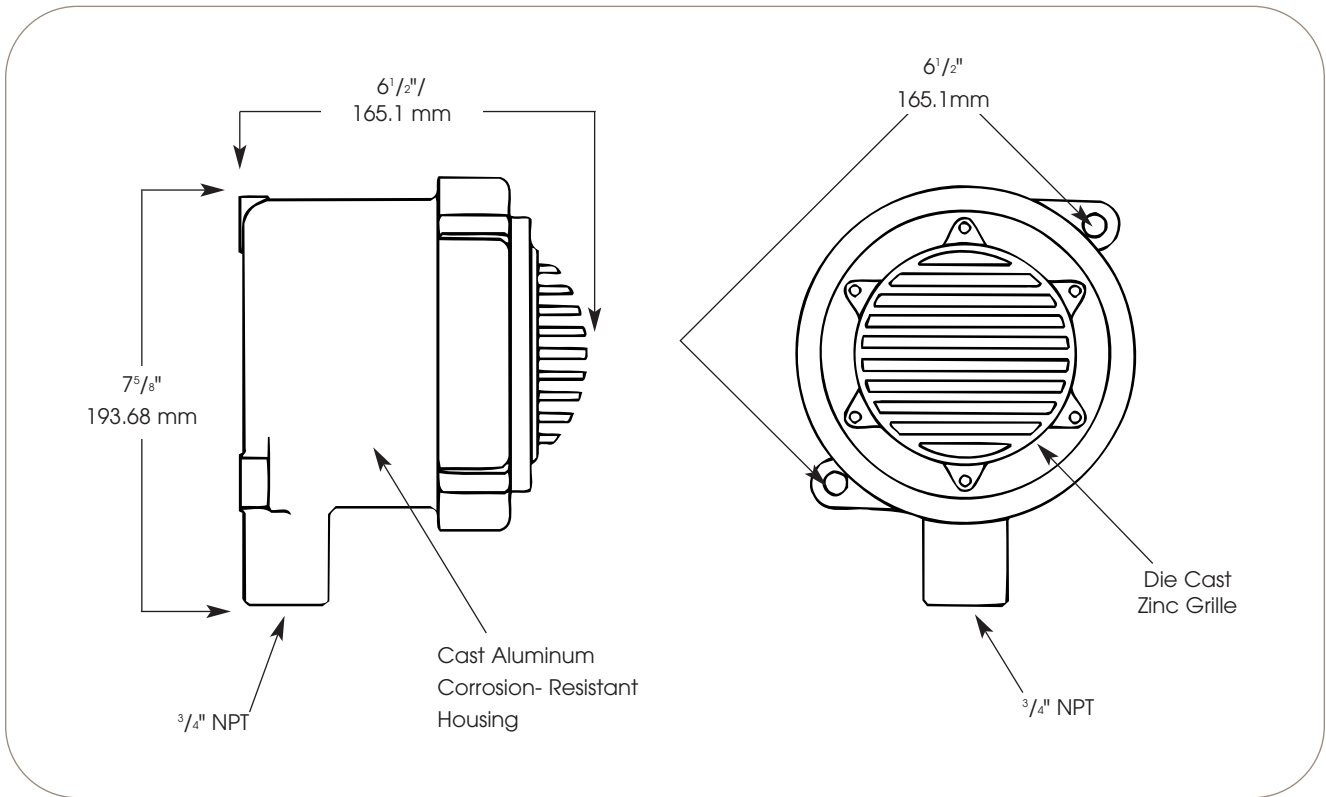

SPECIFICATIONS

Operating Temperature:	-31°F to 150°F	-35°C to 66°C
Net Weight:	9.0 lbs.	4.1 kg
Shipping Weight:	10.3 lbs.	4.7 kg
Height:	7.63"	193.8 mm
Depth:	6.5"	165.1 mm
Diameter:	6.5"	165 mm

HOW TO ORDER

- Specify model number

DISTRIBUTOR

**The Signal Source**  
 Industry's Source for Signaling Solutions  
 P.O. Box 10330 - Palm Desert, CA 92255-033  
 Telephone 800-666-1303 - 760-341-3609  
 Fax 888-436-4277 - 760-346-0763  
 sales@thesignalsource.com - www.thesignalsource.com