

INSTALLATION AND OPERATION MANUAL

FSV10D1(M,S)1(ST,FC)

10-BIT DIGITAL VIDEO TRANSMITTER
WITH BIDIRECTIONAL RS422 OR COAXITRON®
UP-THE COAX DATA FOR PELCO™ DOME CAMERAS

The FSV10D1(M,S)1(ST,FC) series video transmitters and receivers support simultaneous broadcast-quality video transmission of 10-bit digital video and bidirectional RS422 data or Coaxitron® up-the-coax protocol, utilizing time-based correction to achieve distances up to 69km (43mi), over one multimode or single mode optical fiber. The transmitters are designed to plug directly into the Pelco Spectra® IV dome, and connect with power, video input and two way data via the Pelco electrical connector. See **Figure 3** on **Page 4** for in-dome installation instructions.



The receiver can be configured to communicate with the in-dome transmitter in RS422 or Coaxitron mode. See **Figures 7** and **8** on **Page 6** for configuration settings.

See **Figures 1 – 8** for complete installation details.

IMPORTANT SAFETY INSTRUCTIONS

1. Read these instructions.
2. Keep these instructions.
3. Heed all warnings.
4. Follow all instructions.
5. Do not use this apparatus near water.
6. Clean only with dry cloth.
7. Do not block any ventilation openings. Install in accordance with the manufacturer's instructions.
8. Do not install near any heat sources such as radiators, heat registers, stoves, or other apparatus (including amplifiers) that produce heat.
9. Do not defeat the safety purpose of the polarized or grounding-type plug. A polarized plug has two blades with one wider than the other. A grounding type plug has two blades and a third grounding prong. The wide blade or the third prong are provided for your safety. If the provided plug does not fit into your outlet consult an electrician for replacement of the obsolete outlet.
10. Protect the power cord from being walked on or pinched particularly at plugs, convenience receptacles, and the points where they exit from the apparatus.
11. Only use attachments/accessories specified by the manufacturer.
12. Use only with the cart, stand, tripod, bracket, or table specified by the manufacturer, or sold with the apparatus. When a cart is used, use caution when moving the cart/apparatus combination to avoid injury from tip-over.
13. Refer all servicing to qualified service personnel. Servicing is required when the apparatus has been damaged in any way, such as power-supply cord or plug is damaged, liquid has been spilled or objects have fallen into the apparatus, the apparatus has been exposed to rain or moisture, does not operate normally, or has been dropped.
14. Apparatus shall not be exposed to dripping or splashing and that no objects filled with liquids, such as vases shall be placed on the apparatus.
15. **WARNING:** To reduce the risk of fire or electric shock, do not expose this apparatus to rain or moisture.
16. Installation should be done only by qualified personnel and conform to all local codes.
17. Unless the unit is specifically marked as a NEMA Type 3, 3R, 3S, 4, 4X, 6, or 6P enclosure, it is designed for indoor use only and it must not be installed where exposed to rain and moisture.
18. Use only installation methods and materials capable of supporting four times the maximum specified load.
19. A CCC-approved power cord must be used to power this equipment when used in China.
20. **CAUTION:** These servicing instructions are for use by qualified service personnel only. To reduce the risk of electric shock do not perform any servicing other than that contained in the operating instructions unless you are qualified to do so.

The product and/or manual may bear the following marks:

-  This symbol indicates that dangerous voltage constituting a risk of electric shock is present within this unit.
-  This symbol indicates that there are important operating and maintenance instructions in the literature accompanying this unit.

CAUTION:

RISK OF ELECTRIC SHOCK.

DO NOT OPEN.

FIGURE 1 – TRANSMITTER

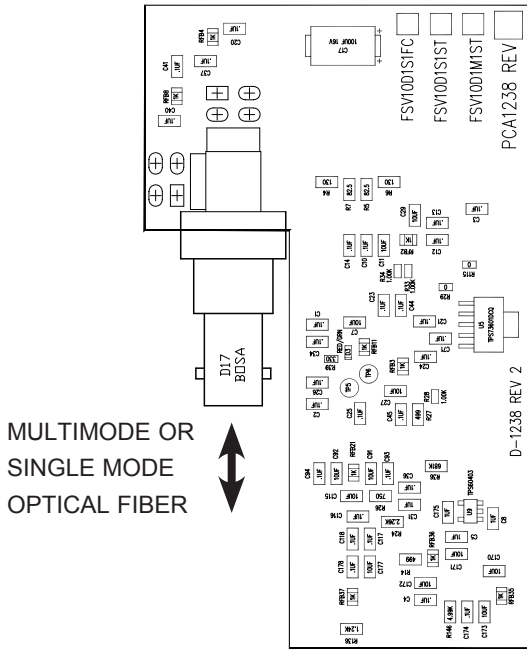

Each model includes one optical fiber cable as follows:

- FSV10D1M1ST – 13 inch multimode ST cable
- FSV10D1S1ST – 13 inch single mode ST cable
- FSV10D1S1FC – 13 inch single mode FC cable

FIGURE 2 – TRANSMITTER

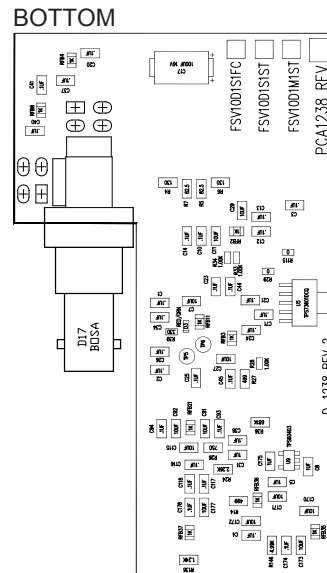
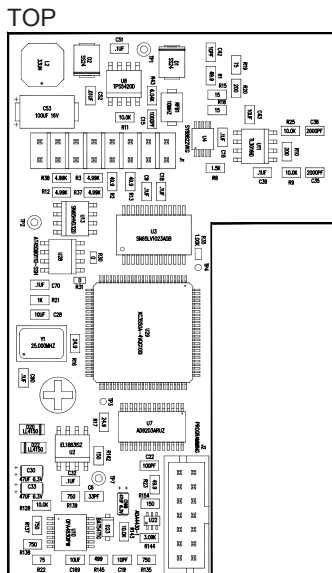
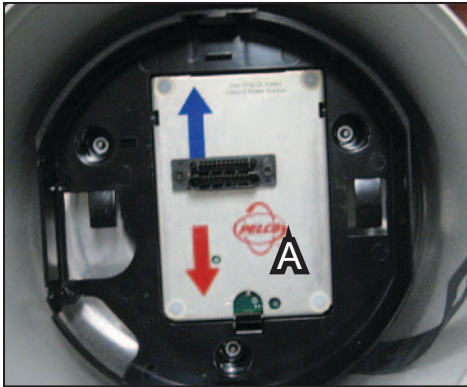
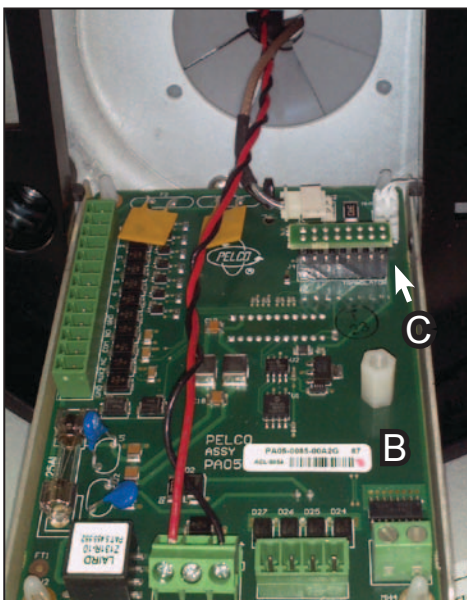

FIGURE 3 – MOUNTING INSTRUCTIONS

See your Pelco Spectra IV Dome installation manual for details of dome installation.



Remove lower dome and dome drive from Spectra IV dome according to the dome's instruction manual to reveal the back box (A).



Open the hinged door of Spectra IV back box to reveal the circuit board (B).

Carefully move the power wiring to the left side of the circuit board (B) as seen in this photo

Remove the plug from the 16-pin connector on the circuit board (C).

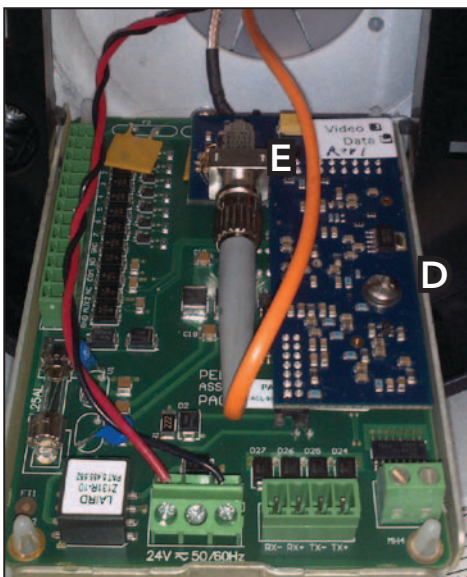

Align the 16-pin connector on the dome circuit board with its counterpart on the top of the FSV10S1 and plug the header into the connector.

Using the supplied Phillips pan head screw with lock washer, secure the transmitter into the mounting standoff on the dome circuit board (D).

Connect the fiber optic connector on the transmitter to the dome's fiber optic adapter (E), and route fiber optic cable.

FIGURE 3 – MOUNTING INSTRUCTIONS (CONT'D)

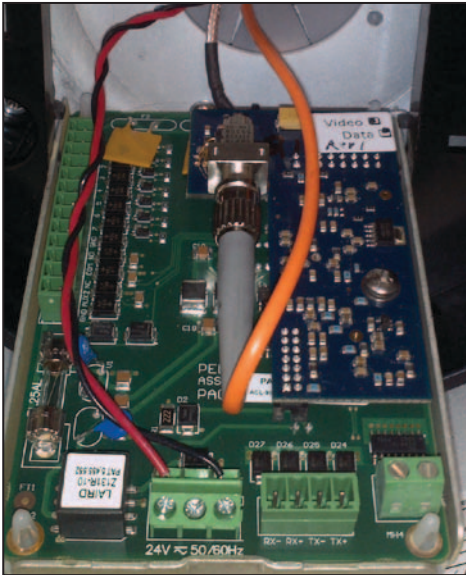

Route the power cord from the 24 volt power connector away from the fiber transmitter, as seen demonstrated by the red and black wires here. Do not leave a “service loop” of power cord in the back box. All slack wire should be removed from the power cord.

If you are not installing alarm or relay connections, then close the back box and replace the dome drive and lower dome according to the dome’s instruction manual.

FIGURE 4 – INSTALLING ALARM AND RELAY WIRING

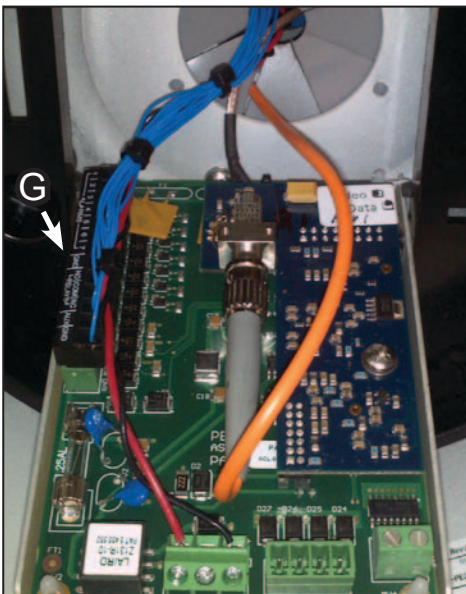

The Spectra allows for the use of alarms and relays through the 13-pin connector on the left side of the dome circuit board (G).

After attaching the alarm and relay wiring to this connector, use the included plastic tie wraps to carefully gather the alarm, relay and power wires into one bundle. Route that bundle out of the Spectra back box on the left hand side, away from the fiber transmitter, as seen in this image. Do not leave a “service loop” of power cord in the back box. All slack wire should be removed from the power cord.

Close the back box and replace the dome drive and lower dome according to the dome’s instruction manual.

Routing the power or the power and alarm and relay wires in this manner increases the Spectra’s electromagnetic compatibility. This will increase performance in electrically “noisy” environments.

MECHANICAL INSTALLATION INSTRUCTIONS

FIGURE 5 – LED INDICATORS (RECEIVER)

As displayed on FRV10D1(M,S)1(ST,FC) Receiver

	LINK	VIDEO	DATA IN	DATA OUT	POWER
GREEN	Communication link has been established over optical fiber	An active video signal is present on the BNC connector.	An active data signal is present on the input pins of the data connector.	An active data signal is present on the output pins of the data connector.	Unit powered up
RED	Communication link has not been established.	–	–	–	–
OFF	Unit powered down.				

FIGURE 6 – LED INDICATORS (TRANSMITTER)

Visible when camera is not installed in dome, the back box board is swung down, the FSV10D1(M,S)1(ST,FC) is plugged in using the fiber optic connector and the 16-pin connector in the dome circuit board and the back box is powered up.

Note: Selection of data format (RS-422 or Coaxitron) is made on receiver. The transmitter need not be configured.

LED	LINK
GREEN	BLINKING Communication link has been established over optical fiber and is configured for Coaxitron communication
	SOLID Communication link has been established over optical fiber and is configured for RS-422 communication
RED	Communication link has not been established.
OFF	Unit powered down.

FIGURE 7 – DATA CHANNEL CONNECTIONS

To be used on FRV10D1(M,S)1(ST,FC) Receiver

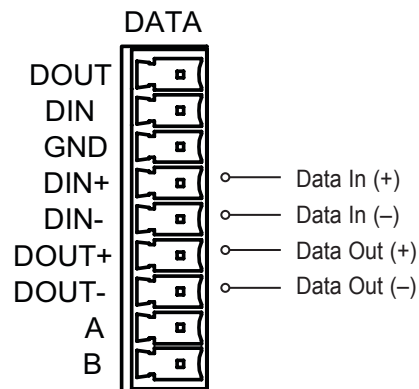
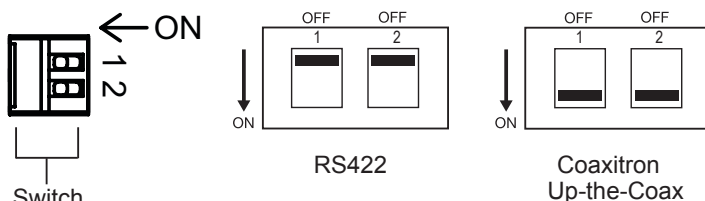

FIGURE 8 – SWITCH POSITIONS

As set on FRV10D1(M,S)1(ST,FC) Receiver



INSTALLATION CONSIDERATIONS

This fiber-optic link is supplied as an in-dome mountable module. Units should be installed in dry locations protected from extremes of temperature and humidity.

WARNING: Unit is to be used with a Listed Class 2 or LPS power supply.

IMPORTANT SAFEGUARDS:

A) Elevated Operating Ambient - If installed in a closed or multi-unit rack assembly, the operating ambient temperature of the rack environment may be greater than room ambient. Therefore, consideration should be given to installing the equipment in an environment compatible with the maximum ambient temperature (T_{ma}) specified by the manufacturer.

B) Reduced Air Flow - Installation of the equipment in a rack should be such that the amount of air flow required for safe operation of the equipment is not compromised.

PRODUCT WARRANTY AND RETURN INFORMATION

WARRANTY

Pelco will repair or replace, without charge, any merchandise proved defective in material or workmanship **for a period of one year** after the date of shipment.

Exceptions to this warranty are as noted below:

- Five years:
 - Fiber optic products
 - Unshielded Twisted Pair (UTP) transmission products
 - CC3701H-2, CC3701H-2X, CC3751H-2, CC3651H-2X, MC3651H-2, and MC3651H-2X camera models
- Three years:
 - FD Series and BU Series analog camera models
 - Fixed network cameras and network dome cameras with Sarix® technology
 - Sarix thermal imaging products (TI and ESTI Series)
 - Fixed analog camera models (C20 Series, CCC1390H Series, C10DN Series, and C10CH Series)
 - EH1500 Series enclosures
 - Spectra® IV products (including Spectra IV IP)
 - Spectra HD dome products
 - Camclosure® IS Series integrated camera systems
 - DX Series video recorders (except DX9000 Series which is covered for a period of one year), DVR5100 Series digital video recorders, Digital Sentry® Series hardware products, DVX Series digital video recorders, and NVR300 Series network video recorders
 - Endura® Series distributed network-based video products
 - Genex® Series products (multiplexers, server, and keyboard)
 - PMCL200/300/400 Series LCD monitors
 - PMCL5xxF Series and PMCL5xxNB Series LCD monitors
- Two years:
 - Standard varifocal, fixed focal, and motorized zoom lenses
 - DF5/DF8 Series fixed dome products
 - Legacy® Series integrated positioning systems
 - Spectra III™, Spectra Mini, Spectra Mini IP, Esprit®, ExSite®, ExSite IP, and PS20 scanners, including when used in continuous motion applications
 - Esprit Ti and TI2500 Series thermal imaging products
 - Esprit and WW5700 Series window wiper (excluding wiper blades)
 - CM6700/CM6800/CM9700 Series matrix
 - Digital Light Processing (DLP®) displays (except lamp and color wheel). The lamp and color wheel will be covered for a period of 90 days. The air filter is not covered under warranty.

- Six months:

- All pan and tilts, scanners, or preset lenses used in continuous motion applications (preset scan, tour, and auto scan modes)

Pelco will warrant all replacement parts and repairs for 90 days from the date of Pelco shipment. All goods requiring warranty repair shall be sent freight prepaid to a Pelco designated location. Repairs made necessary by reason of misuse, alteration, normal wear, or accident are not covered under this warranty.

Pelco assumes no risk and shall be subject to no liability for damages or loss resulting from the specific use or application made of the Products. Pelco's liability for any claim, whether based on breach of contract, negligence, infringement of any rights of any party or product liability, relating to the Products shall not exceed the price paid by the Dealer to Pelco for such Products. In no event will Pelco be liable for any special, incidental, or consequential damages (including loss of use, loss of profit, and claims of third parties) however caused, whether by the negligence of Pelco or otherwise.

The above warranty provides the Dealer with specific legal rights. The Dealer may also have additional rights, which are subject to variation from state to state.

If a warranty repair is required, the Dealer must contact Pelco at (800) 289-9100 or (559) 292-1981 to obtain a Repair Authorization number (RA), and provide the following information:

1. Model and serial number
2. Date of shipment, P.O. number, sales order number, or Pelco invoice number
3. Details of the defect or problem

If there is a dispute regarding the warranty of a product that does not fall under the warranty conditions stated above, please include a written explanation with the product when returned.

Method of return shipment shall be the same or equal to the method by which the item was received by Pelco.

RETURNS

To expedite parts returned for repair or credit, please call Pelco at (800) 289-9100 or (559) 292-1981 to obtain an authorization number (CA number if returned for credit, and RA number if returned for repair) and designated return location.

All merchandise returned for credit may be subject to a 20 percent restocking and refurbishing charge.

Goods returned for repair or credit should be clearly identified with the assigned CA or RA number and freight should be prepaid.

Revised 1-12-12



This equipment contains electrical or electronic components that must be recycled properly to comply with Directive 2002/96/EC of the European Union regarding the disposal of waste electrical and electronic equipment (WEEE). Contact your local dealer for procedures for recycling this equipment.



www.pelco.com

Pelco, Inc. 625 W. Alluvial, Fresno, California 93711 United States
USA & Canada Tel (800) 289-9100 Fax (800) 289-9150
International Tel +1 (559) 292-1981 Fax +1 (559) 348-1120