

# HDSL24UL HEAVY-DUTY VARIABLE SPEED SLIDE GATE OPERATOR

SECTION 32 31 00



## KEY FEATURES

### BATTERY BACKUP

Up to 120 days of standby power or 45 cycles when the power is down

### REMOTE CONTROL ACCESS

Security+ 2.0® 3-channel receiver will handle up to 50 remote controls (unlimited remotes with 811LM/813LM)

### INTERNET CONNECTIVITY

myQ® Business™ cloud connection and myQ capability for secure monitoring and control of gate operator from anywhere\*

### MONITORED SAFETY INPUTS

6 inputs (main and expansion board)

### SOLAR-POWER CAPABILITIES

Yes. Reference detailed solar chart on product page at LiftMaster.com

### DIAGNOSTIC DISPLAY

LED diagnostic display

### WIRELESS DUAL-GATE COMMUNICATION

Eliminates expensive conduit costs and unsightly driveway scars

### DUAL-GATE CONTROL

Bi-part delay or synchronized close

### FIRE DEPARTMENT COMPLIANT

Allows gate to auto open upon loss of AC power or battery depletion: includes manual release

### LIMIT SETTING

Electronic

### PROGRAMMABLE AUXILIARY RELAYS

4 programmable auxiliary relays accommodate more accessories such as warning lights/alarms

### UNAUTHORIZED ACCESS PREVENTION

Can be programmed with anti-tailgate or quick close capabilities

### HOMELINK® COMPATIBLE

Version 4 or higher

## SPECIFICATIONS

### OPERATOR SPEED

.5 ft./sec. to 1 ft./sec.

### POWER

120/240VAC single phase

### ACCESSORY POWER

24VDC 1 A max. output; switched and unswitched power

### OPERATOR WEIGHT

172 lbs.

### WARRANTY

5 years commercial, 7 years residential

### TEMPERATURE SPECIFICATIONS

Without heater: -4°F (-20°C) to 140°F (60°C); with optional heater: -40°F (-40°C) to 140°F (60°C)

### UL USAGE CLASSIFICATION

Class I, II, III and IV

## CONSTRUCTION

### MOTOR

24VDC brushless motor with soft start/stop

### OPERATOR DUTY RATING

Continuous-duty

### CHASSIS/FRAME

Constructed with 1/4 in. powder coated steel for rust prevention

### GEAR REDUCTION

Direct drive 40:1 gear ratio

### COVER

High-density, UV-resistant polyethylene 1-piece cover for excellent heat and corrosion resistance

### RECOMMENDED CAPACITIES

Rated for gates up to 75 ft. in length and weighing up to 3,000 lbs.

\*When linked with a myQ Business capable access control. Cellular data or Wi-Fi® connection required.

DATA SHEET  
SLIDE GATE OPERATOR



**LiftMaster**®

# HDSL24UL HEAVY-DUTY VARIABLE SPEED SLIDE GATE OPERATOR

## SECTION 32 31 00

### DIMENSIONS

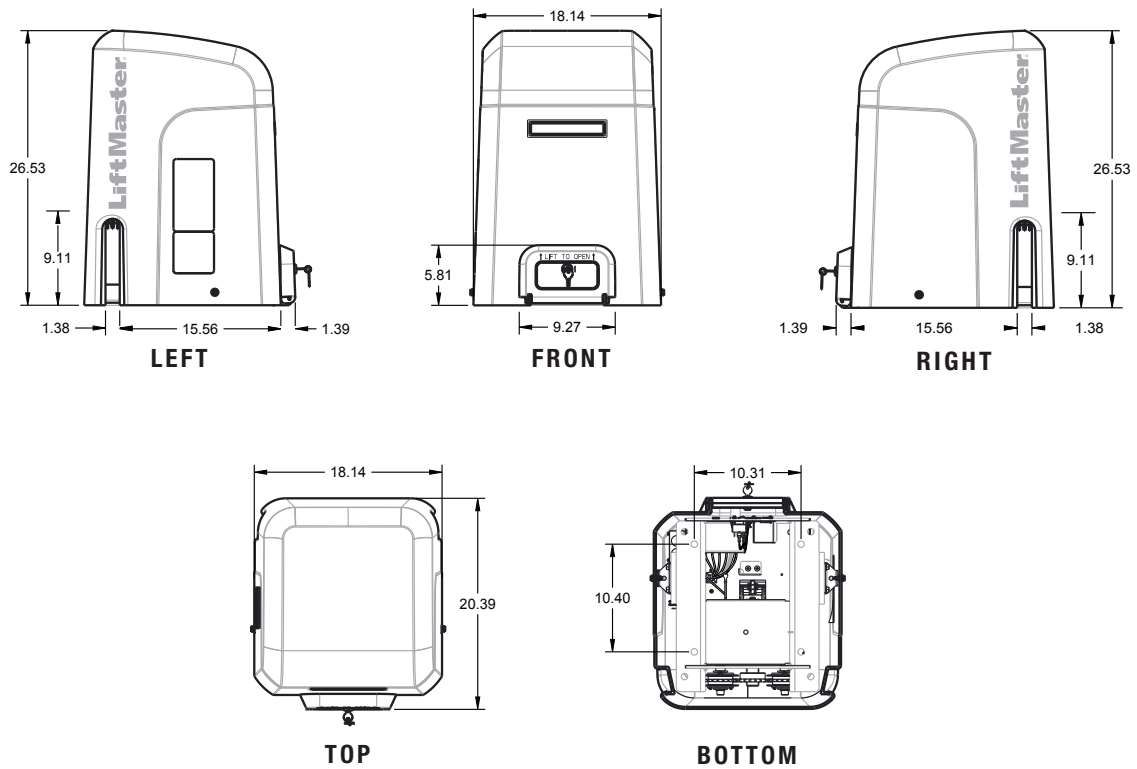

### CAPACITY

#### BATTERY BACK-UP OPERATION

BATTERY	CYCLES	STANDBY TIME
7Ah	45	120 DAYS
33Ah	190	180 DAYS

Cycles and Standby Time Based on Stand-Alone System

