



FLUSH MOUNT (-F Model)



SURFACE MOUNT (IR-S Model)

# ConteralP<sup>®</sup> MicroDome<sup>®</sup> LX

## Installation Manual

### FLUSH MOUNT (-F Model)

---

1080P		5MP	
AV2756DN-F	AV2756DN-F-NL	AV5756DN-F	AV5756DN-F-NL

### SURFACE MOUNT (IR-S Model)

---

1080P		5MP	
AV2756DNIR-S	AV2756DNIR-S-NL	AV5756DNIR-S	AV5756DNIR-S-NL



# Table of Contents

About Our Warranty .....	2
Global (3 Year) Limited Warranty .....	2
Camera Overview .....	3
Package Contents.....	4
Installation .....	5
In-ceiling (-F Model) Installation .....	5
Surface Mount (IR-S Model) .....	9
Pendant Mount (IR-S Model) .....	13
Wall Mount (IR-S Model).....	14
Changing the Lens .....	15
Lens Options .....	<b>16</b>
Removing the Bubble (-F Model) .....	16
Camera Power Up.....	17
Reset to Factory Default .....	19
Audio/SD Card Info .....	20
Camera Discovery, Setup, and Configuration.....	21
Camera Discovery.....	22
Web Interface Navigation.....	23
Image .....	25
Video & Audio.....	30
Focus.....	34
Network .....	35
Privacy Mask.....	42
Event .....	43
System Options .....	51
Administration.....	53
About .....	54
Support.....	55

# About Our Warranty

## Global (3 Year) Limited Warranty

AV COSTAR™ warrants to Purchaser (and only Purchaser) (the “Limited Warranty”), that: (a) each Product shall be free from material defects in material and workmanship for a period of thirty-six (36) months from the date of shipment (the “Warranty Period”); (b) during the Warranty Period, the Products will materially conform with the specification in the applicable documentation; (c) all licensed programs accompanying the Product (the “Licensed Programs”) will materially conform with applicable specifications. Notwithstanding the preceding provisions, AV COSTAR™ shall have no obligation or responsibility with respect to any Product that (i) has been modified or altered without AV COSTAR’s written authorization; (ii) has not been used in accordance with applicable documentation; (iii) has been subjected to unusual stress, neglect, misuse, abuse, improper storage, testing or connection; or unauthorized repair; or (iv) is no longer covered under the Warranty Period. AV COSTAR™ MAKE NO WARRANTIES OR CONDITIONS, EXPRESS, IMPLIED, STATUTORY OR OTHERWISE, OTHER THAN THE EXPRESS LIMITED WARRANTIES MADE BY AV COSTAR™ ABOVE, AND AV COSTAR™ HEREBY SPECIFICALLY DISCLAIMS ALL OTHER EXPRESS, STATUTORY AND IMPLIED WARRANTIES AND CONDITIONS, INCLUDING THE IMPLIED WARRANTIES OF MERCHANTABILITY, FITNESS FOR A PARTICULAR PURPOSE, NON-INFRINGEMENT AND THE IMPLIED CONDITION OF SATISFACTORY QUALITY. ALL LICENSED PROGRAMS ARE LICENSED ON AN “AS IS” BASIS WITHOUT WARRANTY. AV COSTAR™ DOES NOT WARRANT THAT (I) THE OPERATION OF THE PRODUCTS OR PARTS WILL BE UNINTERRUPTED OR ERROR FREE; (II) THE PRODUCTS OR PARTS AND DOCUMENTATION WILL MEET THE END USERS’ REQUIREMENTS; (III) THE PRODUCTS OR PARTS WILL OPERATE IN COMBINATIONS AND CONFIGURATIONS SELECTED BY THE END USER; OTHER THAN COMBINATIONS AND CONFIGURATIONS WITH PARTS OR OTHER PRODUCTS AUTHORIZED BY AV COSTAR™ OR (IV) THAT ALL LICENSED PROGRAM ERRORS WILL BE CORRECTED.

For RMA and Advance Replacement information visit <http://www.avcostar.com>

# Camera Overview

The ConteralP® MicroDome® LX megapixel cameras feature 1080p or 5-megapixel (MP) resolutions for optimum performance with a day/night mechanical IR cut filter and interchangeable lenses. Regardless of the time of day, the ConteralP® MicroDome® LX is prepared for any lighting condition. For applications with poor lighting conditions, Enhanced WDR (wide dynamic range) at 120dB provides the best visual balance to shaded and bright light conditions. For clear color images in low-light, NightView™ offers strong low-light sensitivity for capturing details in extremely poor-lit scenes, and is further enhanced in IR-S models by built-in IR LED illumination. ConteralP® MicroDome® LX cameras deliver professional surveillance, with ease of installation and set-up, for a variety of network surveillance requirements. The three-axis lens adjustment provides users with more camera placement options and the remote focus module allows users to adjust the camera focus after installation. An innovative spring arm design makes in-ceiling -F model installations a snap: simply slide the camera through the hole and secure the magnetized cover ring with a single screw. No additional hardware is required. The ConteralP® MicroDome® LX camera series is available in an indoor, in-ceiling housing or in a surface mount. IP66 rated version for indoor and outdoor applications. All models feature a vandal resistant, IK-10 rated cast-aluminum housing with a polycarbonate bubble making it capable of withstanding the equivalent of 55 kg (120 lbs) of force.

AV Costar™ was the first to bring H.264 to the mainstream market and recently developed SNAPstream™ (Smart Noise Adaptation and Processing) technology for reducing bandwidth without impacting image quality. Today we are proud to offer our next generation H.265 with SNAPstream+™ smart codec capable of delivering high quality video while saving over 50% of the data rate to reduce or prevent strain on the network.

The SD card slot supports up to 256GB of storage capacity for convenient onboard storage. The camera's power can be supplied via a Power-over-Ethernet (PoE - IEEE 802.3af) compliant network cable connection.

The ConteralP® MicroDome® LX is ONVIF (Open Network Video Interface Forum) Profile S, G, and T compliant, providing interoperability between network video products regardless of manufacturer.

# Package Contents

- AV2756DN-F / AV5756DN-F / AV2756DNIR-S / AV5756DNIR-S

Description	QTY
AV2756DN-F / AV5756DN-F / AV2756DNIR-S / AV5756DNIR-S IP camera	1
Mounting Template	1
Mounting Kit	1
Accessory Pack	1

# Installation

## In-ceiling (-F Model) Installation

1. Determine a secure location to mount the camera. Cut a hole in the ceiling using the template provided (3.25 inches in diameter) to fit the camera housing.
2. Remove the dome cover from the camera by unscrewing the captive fastener.

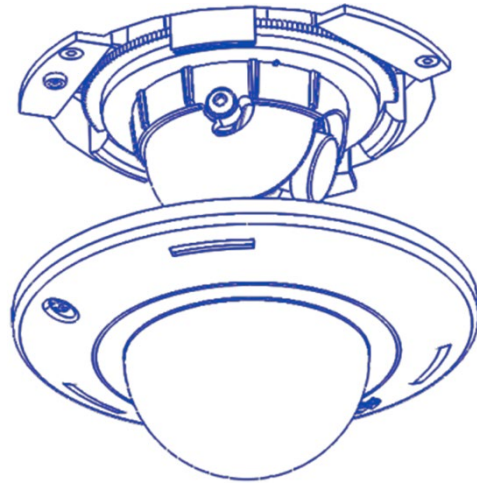

Reference #	Description
1	Captive Fastener
2	Dome Cover
3	Camera Head

3. Pull the network cable through the ceiling and plug it into the network connector on the camera housing (Note: this can be done at a later time if there is access to the network connector on the camera housing after installation into the ceiling).
4. Check that the indicator LED's are illuminated to the desired conditions (see LED Indicator table).
5. Push the three spring actuated retention arms to the upward position as shown in the diagram.

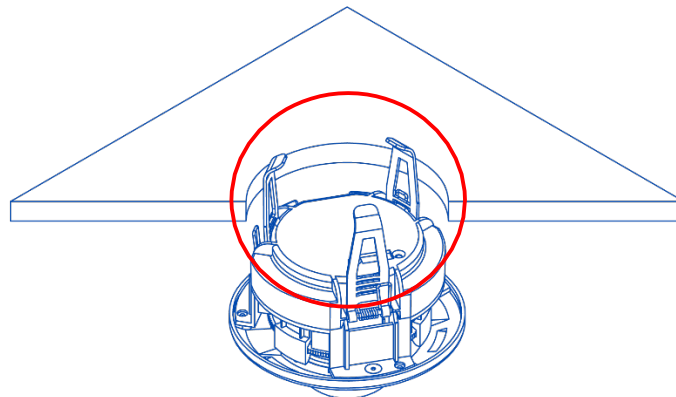

6. Insert the camera housing through the ceiling until the retention arms lock into place.

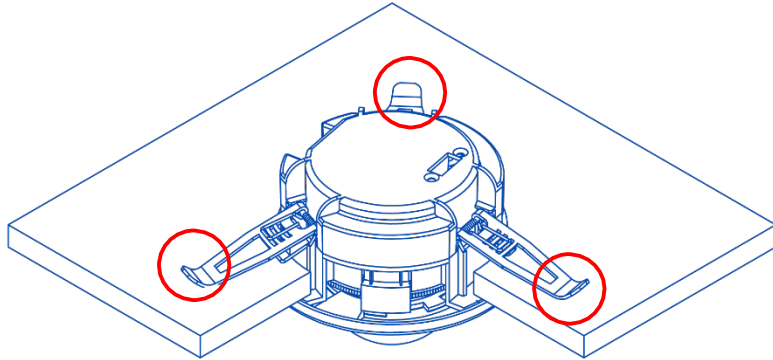

7. Adjust the pan and tilt to obtain the desired field of view. Then, lock the camera head in place by tightening at least two of the three set-screws with the supplied flat-head screwdriver. Do not over torque the screws.

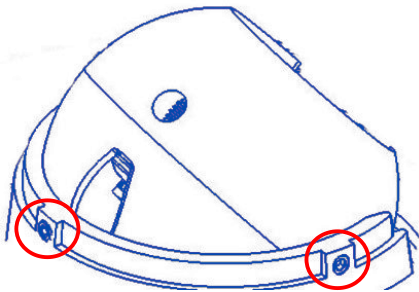

**NOTE:** Ensure not to press the remote focus motor against the sides of camera module when adjusting the field of view. Refer to the below image.

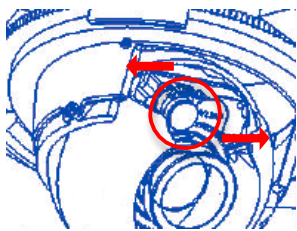

8. Install the dome cover by aligning the captive fastener with the mating threaded insert on the camera housing. The cover is held in place by magnets.

**ⓘ CAUTION!**

The magnets are meant to hold the Dome Cover in place during installation. The captive fastener must be used to properly secure the Dome Cover. Failure to use the captive fastener may result in serious injury.

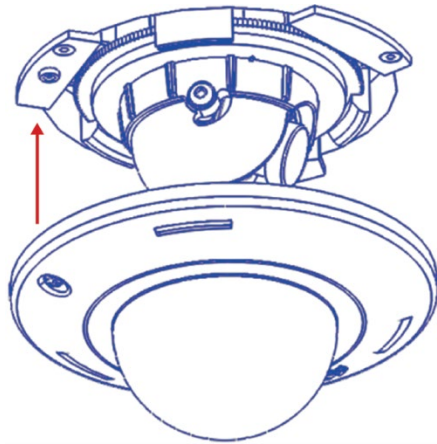

Reference #	Description
1	Captive Fastener

9. Tighten the captive fastener with the supplied Philips head screwdriver to secure the dome cover in place.

***NOTE: The supplied security torx screw may also be used.***

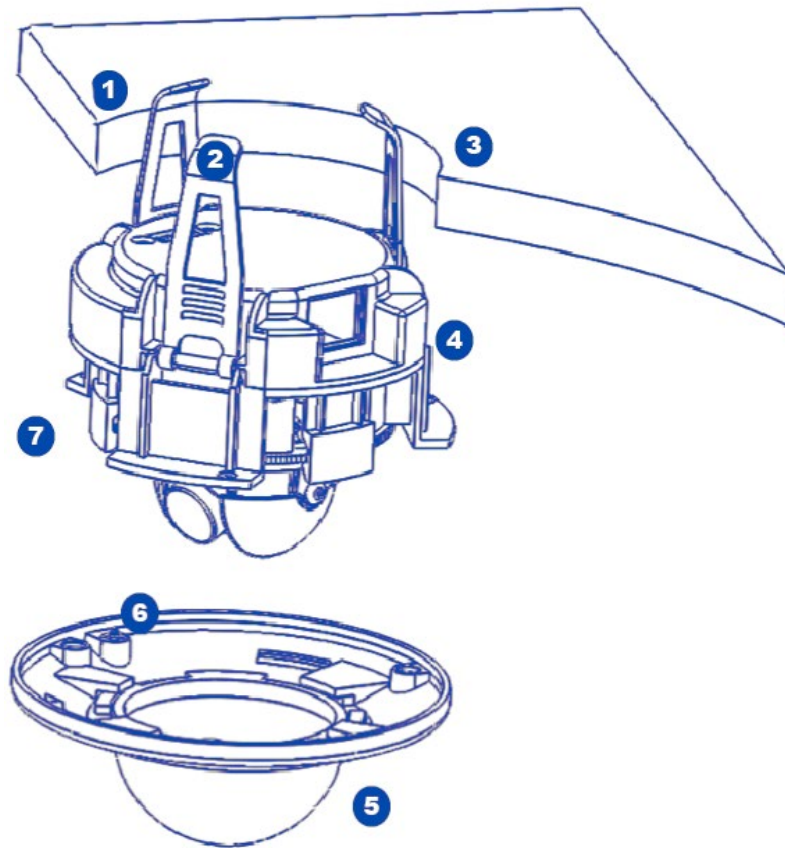

Reference #	Description
1	3.25" Diameter Hole
2	Retention Arms
3	Ceiling
4	RJ-45 Network Connector with LED Indicators
5	Dome Cover
6	Captive Fastener
7	Camera Housing

10. Use the AV Costar™ software AV Costar™ Utility located on our website ([www.avcostar.com](http://www.avcostar.com)) for camera discovery and setup (see Instruction Manual located on our website).

## Surface Mount (IR-S Model)

1. Determine a secure location to mount the camera.
2. Remove the dome cover from the camera by unscrewing the three captive fasteners.

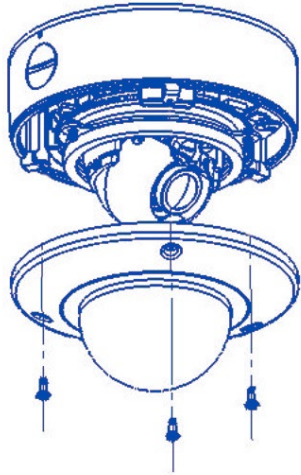

Figure 1: Remove dome cover

3. The camera can be mounted two ways: surface mount or via a junction box to a wall or ceiling.

Choose the best method for your installation below:

- a. **Surface Mount:** use the supplied template to mark three desired holes (there are six holes to choose from; see Figure 3). Then drill the holes with a diameter of 8 mm (0.3 in) and insert the supplied anchors into the holes. Attach the camera module and supplied gasket securely using the supplied screws.

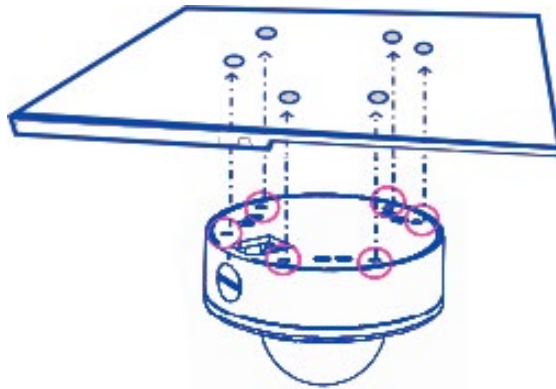

Figure 3: Drill three of the six holes provided.

**NOTE: For installations in harsh environments, it is recommended to use all six mounting screws supplied with the camera to create the best seal possible between the camera and the mounting surface and using the supplied gasket.**

-or-

b. **Junction Box**

1. Install a 4 in. gang box or square metal junction box (not supplied)

**NOTE: ensure openings for cables are accounted for prior to installation.**

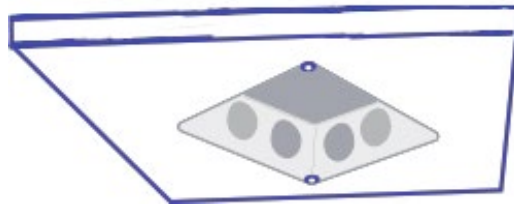
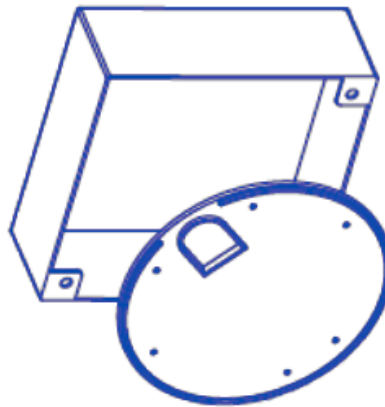

Figure 4: Install 4S junction box (not supplied)

2. Insert the supplied gasket inside the gang box.



3. Insert the camera flush against the gasket inside the 4S gang box; this will be a tight fit.

**NOTE: If you use the side connection of the NPT port, remove the cap covering the side entrance, otherwise; leave the cap in place. If using the NPT port, always use Teflon tape around the threads to ensure proper sealing.**

4. Route the cable tree from the camera around the rear of the camera module and secure all cables. See the Connections section for details on how to connect the camera.

5. Check that the indicator LED's are illuminated to the desired conditions (see LED Indicator table).
6. Adjust the pan and tilt to obtain the desired field of view. Then, lock the camera head in place by tightening at least two of the three set-screws with the supplied flat-head screwdriver.
  - i. Do not over torque the screws.

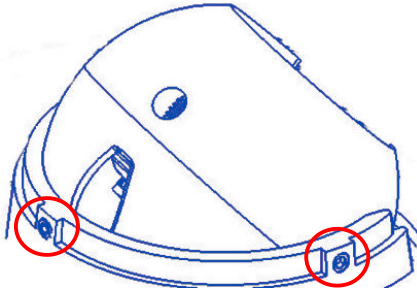

*Lock camera head after adjusting the field of view*

**NOTE: Ensure not to press the remote focus motor against the sides of the camera module when adjusting the field of view.**

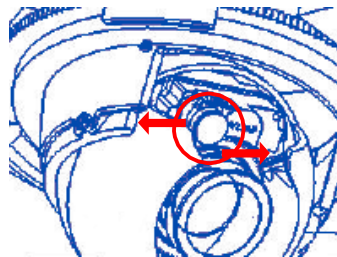

*Remote focus motor*

7. Install the dome cover by aligning the captive fasteners on the camera housing. If installing inside a 4S junction box, the MCD-4S accessory dome cover plate

**ⓘ CAUTION!**

The captive screws must be used to properly secure the dome cover and camera housing. Failure to use the captive fastener may result in serious injury. When mounting the dome cover to the camera housing, ensure that the gasket is properly seated and not folded. Failure to do so may result in water and dust ingress. Water damage from improper installation is not covered by the warranty!

(sold separately) is required.

**NOTE: There's no IR function if using MCD-4S**

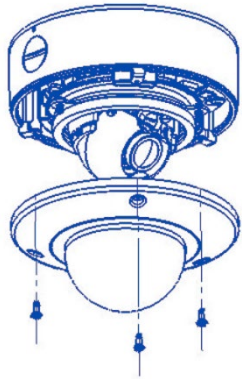

*Attach dome cover with captive fasteners*

8. If using the MCD-4S accessory plate, tighten the two captive fasteners with the supplied Philips head screwdriver to secure the dome cover to the user supplied 4S junction box. Tightly insert the two black plugs supplied with the MCD-4S for the remaining open holes. Cut any excess off the rubber plugs, flush against the dome cover, with a utility knife.

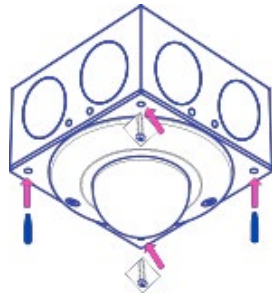

*Attach the MCD-4S accessory plate to the user supplied 4S junction box*

***NOTE: The supplied security torx screws may also be used.***

## Pendant Mount (IR-S Model)

For a proper pendant mount installation, the MCD-CMT-W pendant mount is required (sold separately). A pendant mount should only be attached onto hard ceilings including wood, plastic, metal, and concrete.

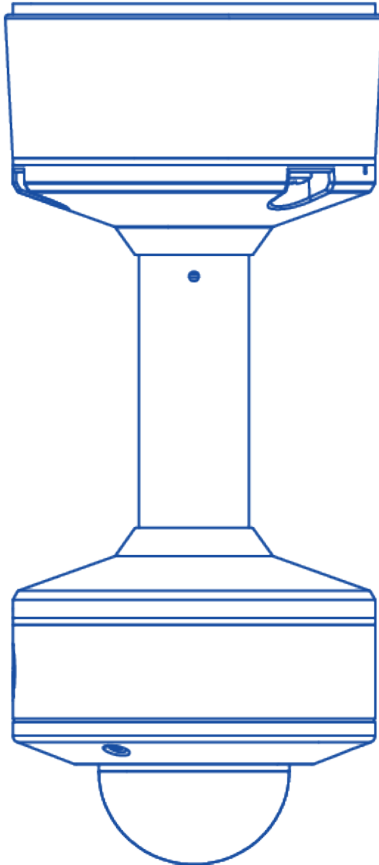

### Installation Notes:

1. Three mounting screws are #10x1" wood or sheet metal screws (Three mount anchors also included).
2. Always ensure gaskets are properly seated.
3. Use Teflon tape on threaded interfaces.
4. 3/8" male to 1/2" female NPT adapter included.
5. Mount holes from camera housing to flange are not symmetrical.

Alignment features indicated must be properly lined up for mount hole alignment.

## Wall Mount (IR-S Model)

For a proper pendant mount installation, the MCD-WMT-W wall mount is required (sold separately). A wall mount should only be attached onto hard ceilings including wood, plastic, metal, and concrete.

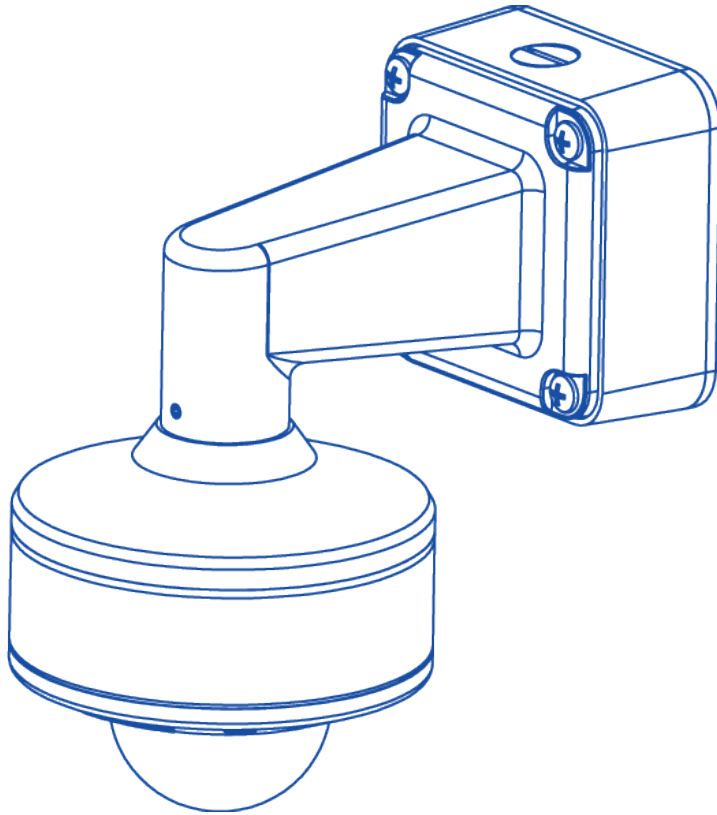

### Installation Notes:

1. Four mounting screws are #10x1" wood or sheet metal screws (Four mount anchors also included).
2. Always ensure gaskets are properly seated.
3. Use Teflon tape on threaded interfaces.
4. 3/8" male to 1/2" female NPT adapter included.
5. Mount holes from camera housing to flange are not symmetrical. Alignment features indicated must be properly lined up for mount hole alignment.

# Changing the Lens

1. Remove the dome cover by loosening the captive fastener with the supplied Philips head screwdriver.

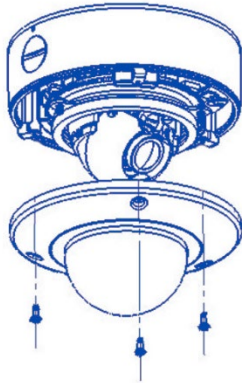

**SURFACE MOUNT (IR-S Model)**

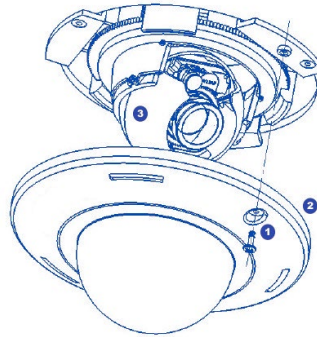

**FLUSH MOUNT (-F Model)**

2. Manually unscrew the lens counterclockwise, this may take several seconds.

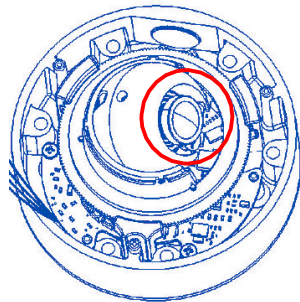

3. Screw the replacement lens clockwise until you feel some resistance and hit a hard stop.
4. Reinstall the dome cover per instructions outlined above.

## Lens Options

**NOTE:** Spacers are required for some lens options. See table below.

Lens Part Number	Description	Numbers of Spacers Needed
MPM2.4	2.4mm	0
MPM2.8C	2.8mm	0
MPM4.0A	4mm	2
MPM6.0	6mm	2
MPM8.0	8mm	2
MPM12.0A	12mm	2
MPM16.0	16mm	1

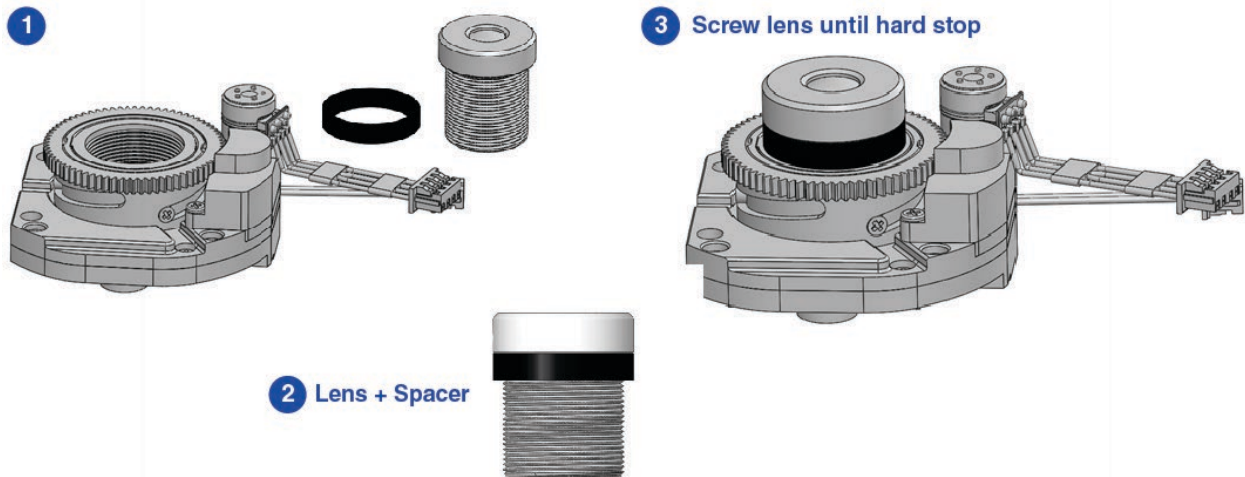

## Removing the Bubble (-F Model)

For best image quality in an indoor environment the bubble can be easily removed.

1. Press down on the 2 locking tabs.
2. Rotate bubble counterclockwise until it becomes free.

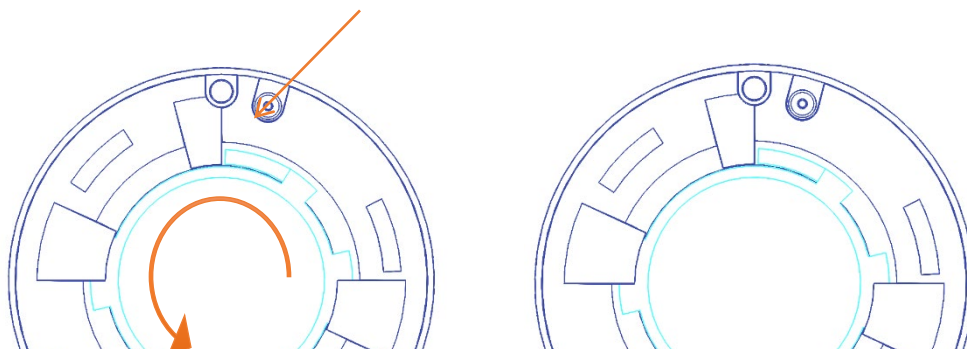

# Camera Power Up

## ⓘ CAUTION!

This product should be installed by a qualified service technician in accordance with the National Electrical Code (NEC 800 CEC Section 60) or applicable local code. Wiring methods should be in accordance with the National Electrical Code/NFPA 70/ANSI, also with all local codes and authorities having jurisdiction. Wiring should be UL Listed and/or Recognized wire suitable for the application.

## ⓘ CAUTION!

Make the connections inside a watertight compartment. Isolate unused power wires individually. After connections are made, ensure that the watertight compartment is tightly closed and cables and conduits are properly sealed to prevent ingress of water.

1. Connect the camera to a PoE port on 100Mbps network PoE switch using an Ethernet cable.

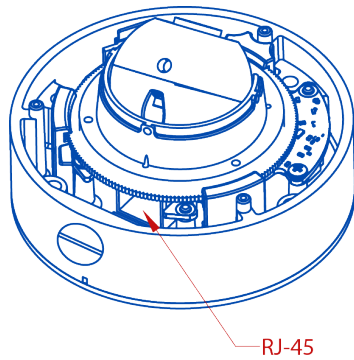

*SURFACE MOUNT (IR-S Model)*

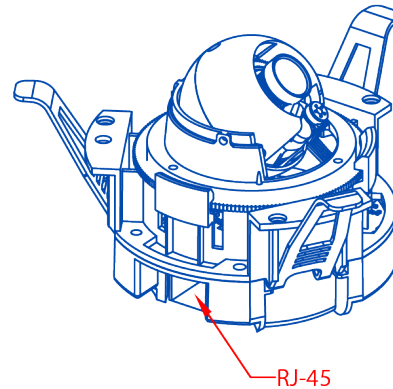

*FLUSH MOUNT (-F Model)*

Connect the PoE switch to your computer's network port by using an ethernet cable.

LED	Status	Description
<b>Green</b>	Quick Flashing	Link has been established
	Slow Flashing	Normal operation
<b>None</b>	None	No Connection

### Camera Installation & Networking Diagram

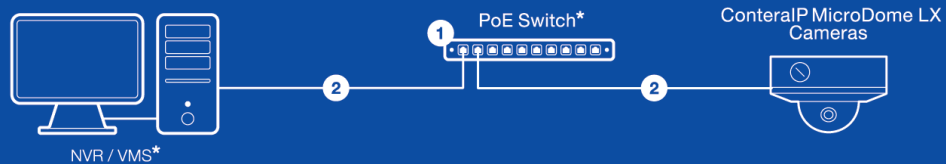

- 1 Compliant with 100Base-T / 1000Base-T Ethernet Network Interface
- 2 Straight-Through CAT5 / CAT5E / CAT6 Cables

\* Sold Separately

# Alarm I/O Functions

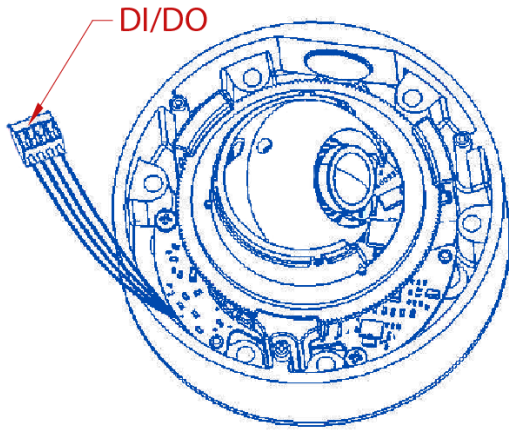

*SURFACE MOUNT (IR-S Model)*

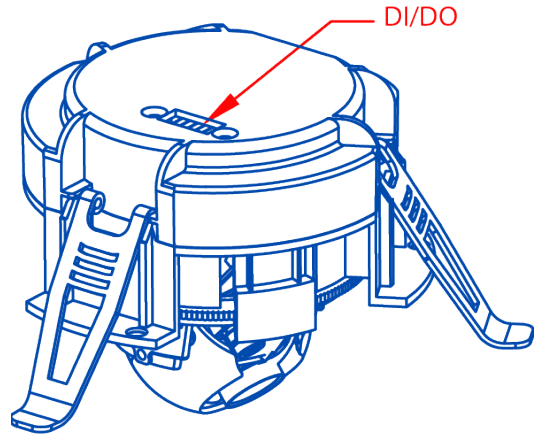

*FLUSH MOUNT (-F Model)*

Connect the Alarm In (DI) connector to the alarm input sensor, and then connect the Alarm Out (DO) connector to the alarm output signal.

To avoid any damage, please follow the specification of the part as below:

Alarm In (Wet Contact)		Alarm Out (Wet Contact)	
3.5-12 VDC	50mA (max)	0-30 VDC	50mA (max)

# Reset to Factory Default

1. Press and hold the reset button for 2 to 5 seconds, then release the reset button.

This resets the camera to the factory default except for the network settings.

2. Press and hold the reset button for more than 5 seconds, then release the reset button.

This resets the camera to the factory default, and this resets the network settings to the factory default.

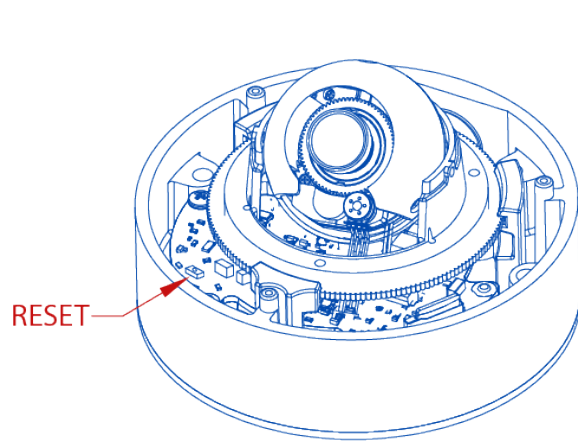

*SURFACE MOUNT (IR-S Model)*

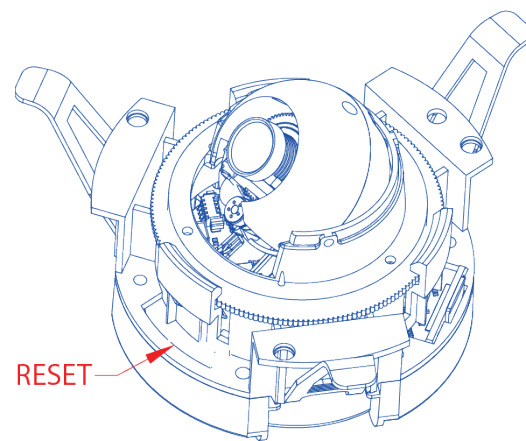

*FLUSH MOUNT (-F Model)*

3. The User can also reset the camera to factory default via the camera web interface or AV Costar™ Utility.

# Audio/SD Card Info

- SD Card Slot

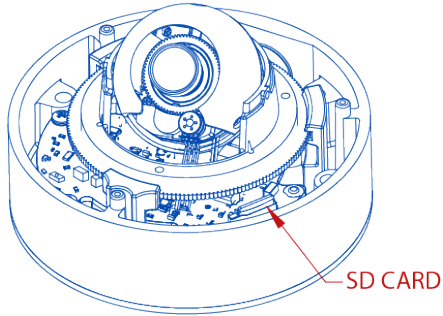

*SURFACE MOUNT (IR-S Model)*

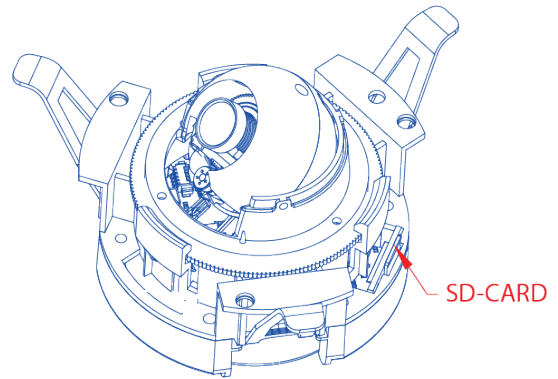

*FLUSH MOUNT (-F Model)*

- Audio Connector

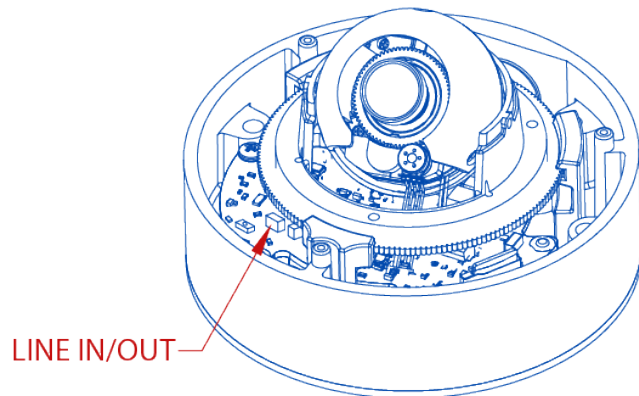

*SURFACE MOUNT (IR-S Model)*

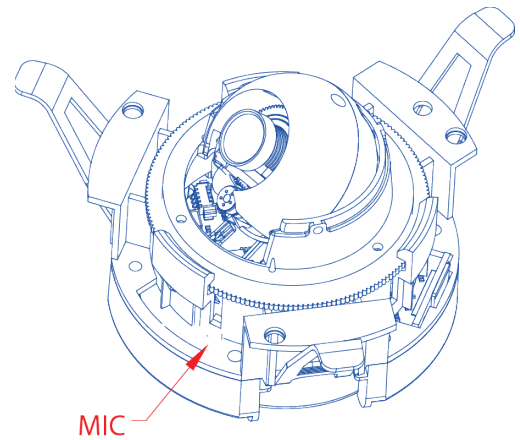

*FLUSH MOUNT (-F Model)*

**NOTE: AV-1AK Accessory Required. Connect Y-Cable to Line In / Line Out connector.**

# Camera Discovery, Setup, and Configuration

AV Costar™ Utility is recommended for camera discovery and setup. Software can be found on the website of AV Costar™ <http://www.avcostar.com/software.php>.

The AV Costar™ Utility can provide multiple discovery options including broadcast and multicast, check the status of a camera, change the camera settings, import and export camera settings via a .csv file, and update firmware and/or hardware from virtually anywhere with a network connection.

The AV Costar™ Utility tool is efficient and convenient for mass or single camera uploads whether used for large installations that require an update to multiple settings, or smaller installations where only one camera needs to be changed.

The AV Costar™ Utility version v3.1.2x+ tool is compatible with all AV Costar™ ConteralP® cameras. The user manual for the software is available on our website.

# Camera Discovery

1. Locate and double click the AV Costar™ Utility shortcut on the desktop.



2. When the AV Costar™ Utility is launched, it will automatically search the ConteralIP® cameras on the network. Also, you can manually search the camera by clicking “Discovery (Multicast)”

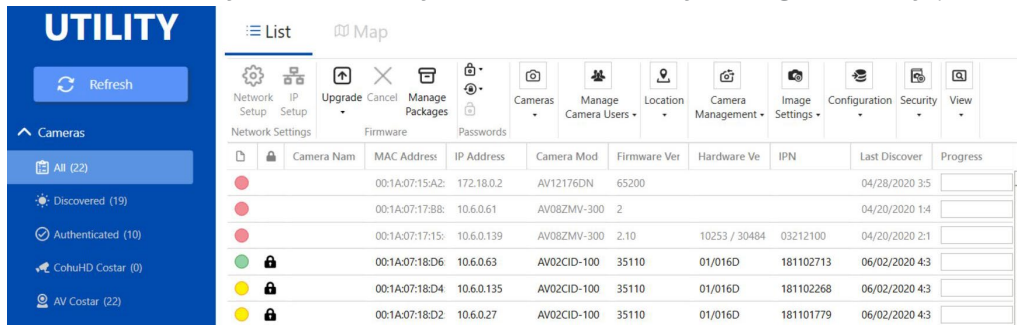

3. You can access the camera’s web interface by typing the camera IP address on the preferred web browser.

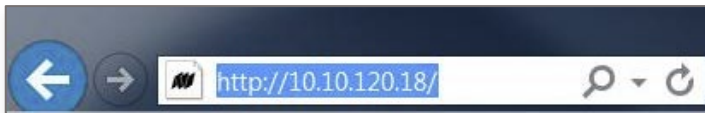

4. If there is no DHCP server present in the network, the camera will default to the following IP Address “192.168.1.168”.

**NOTE: A password must be entered before the camera can be used. To choose a password, visit the camera’s webpage or use the configuration utility.**



## INITIAL PASSWORD SETUP

Prior to accessing this device for the first time a unique admin password must be created:

User Name: **admin**

Password:

Confirm Password:

**Prior to accessing this device for the first time a unique admin password must be created**

## Web Interface Navigation



Image Video & Audio Focus Network Privacy Mask Event System Options Administration About Support

Model AV02CLB-100  
Firmware 35110.4  
MAC 00-14-07-18-b4-e1

The entire menu is located on the top of the web interface.

The following camera settings are available on the top of the menu in the web interface, and the user will be directed to the page that they click on the menu.

- **Image**
  - Image
    - Basic Settings
      - Brightness
      - Sharpness
      - Saturation
      - Contrast
      - Hue
    - Rotate Image
      - 0
      - 90
      - 180
      - 270
    - Mirror Image
      - Flip Vertically
      - Flip Horizontally
    - WDR Mode
    - Stream Profiles
    - Lighting Compensation Frequency
    - Day/Night Mode
  - OSD
    - Camera Name
    - Background
    - Text Overlay
  - ROI
- **Video & Audio**
  - Video
    - Show Video Type
    - Control Video with mouse
    - Resolution
    - Main Stream Configuration
    - Sub Stream Configuration
    - Third Stream Configuration
  - Audio
    - Audio In
    - Encoding



- **Focus**
  - Focus Range
- **Network**
  - Network
    - IP Assignment
      - DHCP
      - Port
        - ◆ HTTP
        - ◆ HTTPS
      - DNS
      - IPv6 Settings
    - QoS (Quality of Service)
    - UPnP (Universal Plug and Play)
    - RTSP (Real Time Streaming Protocol)
    - DDNS (Dynamic DNS)
    - SNMP (Simple Network Management Protocol)
    - SSL (Secure Sockets Layer)
    - FTP (File Transfer Protocol)
    - 802.1x
- **Privacy Mask**
- **Event**
  - Motion Detection
  - Alarm Handler
  - Digital I/O
  - Tamper Detection
  - Network Failure
  - FTP Upload
  - SMTP (Simple Mail Transfer Protocol) Notification
  - Network Storage
  - SD Card
- **System**
  - System Options
    - Firmware Upgrade
    - Configuration Management
    - Download Log
    - Reboot & Restore Settings
    - Camera Name
  - Date/Time
- **Administration**
  - Access Control
  - Administrator settings
  - Viewer Management
- **About**
- **Support**

# Image

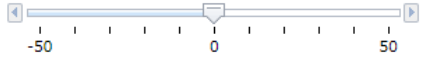

- Image
- Video & Audio
- Focus
- Network
- Privacy Mask
- Event
- System Options
- Administration
- About
- Support

Model AV02CLB-100  
Firmware 35110.4  
MAC 00:1a:07:18:b4:e1

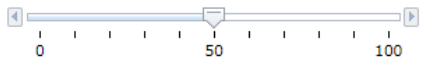
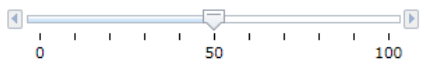
Menu	Feature	Description
<p style="text-align: center;"><b>Image</b></p> <hr/> <p>Brightness: <input style="width: 40px;" type="text" value="0"/></p> 	Brightness	Controls the overall brightness of the camera image and works in conjunction with the exposure controls to maintain the image brightness.
<p>Sharpness: <input style="width: 40px;" type="text" value="2"/></p> 	Sharpness	Controls sharpness and edge definition of the image. Setting this to lower levels may make the overall image appear a bit softer while causing lines and edges in the image to look smoother.
<p>Saturation: <input style="width: 40px;" type="text" value="3"/></p> 	Saturation	Controls the color saturation of the image.
<p>Contrast: <input style="width: 40px;" type="text" value="50"/></p> 	Contrast	Manually controls Gamma level (affects the overall luminance of the image).
<p>Hue: <input style="width: 40px;" type="text" value="50"/></p> 	Hue	Configures the overall hue of the image with a range of 0 ~ 100. Increasing the value will adjust the image hue towards red. Decreasing the value will adjust the image hue towards blue.

<p><b>Rotate Image</b></p> <p><input checked="" type="radio"/> 0  <input type="radio"/> 90  <input type="radio"/> 180  <input type="radio"/> 270</p> <p><b>Mirror Image</b></p> <p><input type="checkbox"/> Flip Vertically  <input type="checkbox"/> Flip Horizontally</p> <p><input checked="" type="checkbox"/> Auto White Balance</p>	<p>Rotate Image</p> <p>Mirror Image</p>	<p>Enable the image rotation on each channel.</p>
<p><b>WDR Mode</b></p> <p><input checked="" type="radio"/> Auto  <input type="radio"/> HDR : <input type="text" value="10"/></p> <p></p> <p><input type="radio"/> DWDR  <input type="radio"/> LDR  <input type="radio"/> Manual</p> <p>DAY  <input type="text" value="LDR"/></p> <p>LOW LIGHT  <input type="text" value="LDR"/></p> <p>B/W  <input type="text" value="LDR"/></p> <p><input checked="" type="checkbox"/> Auto Exposure</p>	<p>Auto</p>	<p>Auto detects bright backlight, glare, or high contrast lighting and automatically selects the WDR level.</p> <p><b>NOTE: WDR enabled will decrease the FPS of 5MP camera.</b>  <b>NOTE: Make sure AE mode is set to "Auto".</b></p>
	<p>HDR</p>	<p>Manually adjusts the intensity of backlight compensation.</p> <p><b>NOTE: WDR enabled will decrease the FPS of 5MP camera.</b>  <b>NOTE: Make sure AE mode is set to "Auto".</b></p>
	<p>Turn off in low light</p>	<p>Disables WDR backlight compensation when the light levels drop for better nighttime image quality.</p>
	<p>Turn off in B/W</p>	<p>Disables WDR backlight compensation when the camera is in night mode for better nighttime image quality.</p>
	<p>DWDR</p>	<p>Digital WDR (DWDR) enhances the dark areas by adjusting the gamma value. This will not impact FPS of 5MP camera.</p>
	<p>LDR</p>	<p>Will not combine long and short exposures into one frame, resulting in better low light performance.</p>
	<p>Auto Exposure</p>	<p>Automatically adjusts illumination and exposure values.</p> <p><b>NOTE: Make sure AE mode is set to "Auto".</b></p>

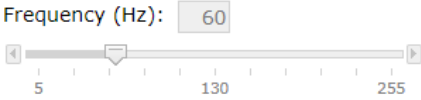
	<p>Stream Profiles: Balance Mode -Slow Shutter Quality Mode</p>	<p><b>Balanced Mode:</b> Limits exposure time from 0.1ms to 66ms. The camera will keep highest FPS when <b>Slow Shutter</b> is unchecked. <b>Quality Mode:</b> Limits exposure time from 0.1ms to 200ms. This mode is a good compromise between reducing noise and motion blur under most lighting conditions, but with an increase in motion blur under low light conditions.</p>
	<p>Moonlight Mode Custom Exposure Mode</p>	<p><b>Moonlight Mode:</b> Limits exposure time from 20ms to 500ms. This mode produces the best image quality under very low light conditions with the least amount of image noise. The trade-off is low noise at the expense of high motion blur.</p> <p><b>Custom Exposure Mode:</b> Enables manual setting of exposure time between 1 and 500ms. Shorter exposure times reduces motion blur for applications such as monitoring fast moving objects and reading license plates. The trade-off is an increased level of noise. It is recommended that this mode is used only when there is constant scene illumination sufficient enough to provide a quality image.</p>
<p><b>Lighting Compensation Frequency</b></p> <p><input type="radio"/> 50hz <input checked="" type="radio"/> 60hz <input type="radio"/> Custom (Custom option is only available if WDR Mode is set to LDR and Auto Exposure is enabled.)</p> <p>Frequency (Hz): <input type="text" value="60"/></p> 	<p>Lighting Compensation Frequency: 50Hz, 60Hz, Custom</p>	<p>Prevents flicker caused by the power line frequency of lighting. Choose 50Hz for Europe or China, and 60Hz for US or Japan. This parameter will have no effect when the dominant light is sunlight. Optionally, the user can select a frequency between 5Hz and 255Hz. It will be enabled when user selects "Custom".</p>

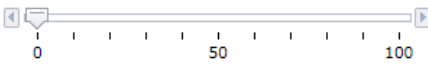
<p><b>Day/Night Mode</b></p> <p> <input checked="" type="radio"/> Automatic  <input type="radio"/> Day  <input type="radio"/> Night  <input type="radio"/> Schedule Day Mode         </p> <p>Start: <input type="text" value="6"/> : <input type="text" value="0"/> (hh:mm)</p> <p>End: <input type="text" value="18"/> : <input type="text" value="0"/> (hh:mm)</p> <p>Defog Level: <input type="text" value="0"/></p> 	<p>Automatic</p> <p>Day</p> <p>Night</p> <p>Schedule Day Mode</p>	<p><b>Automatic:</b> Enables the camera to automatically switch from day mode to night mode. User can define the switching level from Day to Night or Night to Day.</p> <p><b>Day:</b> Forces the camera to stay in day mode.</p> <p><b>Night:</b> Forces the camera to stay in night mode.</p> <p><b>Schedule Day Mode:</b> User defined times that the camera remains in day mode.</p>
<p style="text-align: center; color: blue; font-size: 24px;"><b>OSD</b></p> <p><b>Camera Name</b></p> <p><input type="text" value="Contera Network Camera"/></p> <p><b>Background</b></p> <p> <input type="radio"/> Translucent  <input checked="" type="radio"/> Transparent         </p> <p>Text color: <input type="text" value="White"/></p> <p><b>Text Overlay</b></p> <p>Top Left: <input type="text" value="OFF"/></p> <p>Top Right: <input type="text" value="OFF"/></p> <p>Bottom Left: <input type="text" value="OFF"/></p> <p>Bottom Right: <input type="text" value="OFF"/></p> <p><input type="button" value="Apply"/></p>	<p>Camera Name</p> <p>Background Translucent Transparent</p> <p>Text Color</p> <p>Text Overlay Off Date/Time Camera Name Camera Name + Date/Time Custom Text</p>	<p>Specifies a name for the camera. The maximum name length is 32 characters.</p> <p>Configures the background color of the text overlay. The options are Translucent (light grey) or Transparent.</p> <p>Options are Black, White, Green, or Yellow.</p> <p>There are four content positions (Top Left, Top Right, Bottom Left and Bottom Right) to display the text overlay.</p> <p><b>Date / Time:</b> Displays the current date/time. It will force the camera to synchronize the date/time information.</p> <p><b>Camera Name:</b> Displays the camera name you set.</p> <p><b>Camera Name + Date / Time:</b> Displays both camera name and date/time information.</p> <p><b>Custom Text:</b> Displays a customized text.</p>

<p style="text-align: center;"><b>ROI</b> <span style="float: right;">▼</span></p> <p><small>* Create custom regions of interest by enabling zones below and selecting the desired quality level. Then create the ROI by dragging the mouse over the live image and press "Save Area" or "Del Area".</small></p> <p>Stream: <span style="border: 1px solid black; padding: 2px;">Main Stream ▼</span></p> <p>ROI Zone 1: <input type="checkbox"/> Enable  <span style="border: 1px solid black; padding: 2px;">Medium ▼</span> <span style="border: 1px solid black; padding: 2px; margin-left: 10px;">Save Area</span> <span style="border: 1px solid black; padding: 2px; margin-left: 10px;">Del Area</span></p> <p>ROI Zone 2: <input type="checkbox"/> Enable  <span style="border: 1px solid black; padding: 2px;">Medium ▼</span> <span style="border: 1px solid black; padding: 2px; margin-left: 10px;">Save Area</span> <span style="border: 1px solid black; padding: 2px; margin-left: 10px;">Del Area</span></p> <p>ROI Zone 3: <input type="checkbox"/> Enable  <span style="border: 1px solid black; padding: 2px;">Medium ▼</span> <span style="border: 1px solid black; padding: 2px; margin-left: 10px;">Save Area</span> <span style="border: 1px solid black; padding: 2px; margin-left: 10px;">Del Area</span></p> <p>ROI Zone 4: <input type="checkbox"/> Enable  <span style="border: 1px solid black; padding: 2px;">Medium ▼</span> <span style="border: 1px solid black; padding: 2px; margin-left: 10px;">Save Area</span> <span style="border: 1px solid black; padding: 2px; margin-left: 10px;">Del Area</span></p> <p>ROI Zone 5: <input type="checkbox"/> Enable  <span style="border: 1px solid black; padding: 2px;">Medium ▼</span> <span style="border: 1px solid black; padding: 2px; margin-left: 10px;">Save Area</span> <span style="border: 1px solid black; padding: 2px; margin-left: 10px;">Del Area</span></p>	<p>ROI (Regions of Interest)</p>	<p>ROI (Regions of Interest) is used to select which areas will be monitored and recorded with higher image quality while using lower image quality for other non-ROI zones in order to save bandwidth and storage.</p> <p>To setup the ROI:</p> <ol style="list-style-type: none"> <li>1. Select the desired channel</li> <li>2. Select Main Stream or Sub Stream</li> <li>3. Enable zones (up to five zones) and select the desired quality level (High, Medium, or Low)</li> <li>4. Create the ROI by dragging the mouse over the live image</li> <li>5. Press Save Area or Del Area</li> </ol>

## Video & Audio

Image
Video & Audio
Focus
Network
Privacy Mask
Event
System Options
Administration
About
Support

 Model AV02CLB-100  
 Firmware 35110.4  
 MAC 00-1a-07-18-b4-e1

Menu	Feature	Description
<p style="text-align: center;"><b>Video</b></p> <hr/> <p><b>Show Video Type</b></p> <p> <input type="radio"/> Disable Video  <input checked="" type="radio"/> MJPEG over HTTP  <input type="radio"/> H.264 over RTP/UDP                 </p> <p> <small>* For H.264 streaming, please make sure ActiveX Plugin is installed during VLC installation and axvlc.dll is at exactly the same path as                      C:\Program Files (x86)\VideoLAN\VLC\axvlc.dll</small> </p> <p><input type="checkbox"/> Fit Video to Window</p> <p><b>Control Video with Mouse</b></p> <p> <input checked="" type="radio"/> No Control  <input type="radio"/> PTZ  <input type="radio"/> ROI Exposure Reference                 </p> <p> <small>* Mouse-related control requires running MJPEG video                      * Click and move to select window to set.                      * Double click to reset to default settings.</small> </p>	<p>Show Video Type:</p> <p><b>MJPEG</b></p> <p><b>H.264 Quality</b></p>	<p>The third stream is designed for the live view on web interface, and the only option of Video Compression is MJPEG.</p> <p>H.264 image quality setting for variable bit rate control. Setting a lower value results in higher image quality or setting a higher value results in lower image quality.</p>
<p><b>Resolution</b></p> <p>Left : <input type="text" value="0"/></p> <p>Top : <input type="text" value="0"/></p> <p>Right : <input type="text" value="0"/></p> <p>Bottom : <input type="text" value="0"/></p> <p> <input type="button" value="Preview"/> <input type="button" value="Apply"/> </p>	<p>Resolution</p>	<p>Options vary based on the sensor resolution being used.</p>

<p><b>Main Stream</b></p> <p>Video Compression</p> <p><input type="radio"/> H.265</p> <p><input checked="" type="radio"/> H.264</p> <p>Resolution</p> <p><input checked="" type="radio"/> 1920x1080</p> <p><input type="radio"/> 1280x720</p> <p><input type="radio"/> 960x540</p> <p><input type="checkbox"/> Enable SNAPstream+™</p> <p><input type="radio"/> Variable Bitrate</p> <p><input checked="" type="radio"/> Maximum Bitrate</p> <p>(64-8000 kbps): <input type="text" value="4000"/></p> <p>H.264 Quality (1..10) : <input type="text" value="4"/></p> <p>* 10 - lowest quality, 1 - highest quality</p> <p><input type="radio"/> Constant Bitrate</p> <p>Bitrate : <input type="text" value="4000"/> (64~8000 kbps)</p> <p>Frames Per Seconds: <input type="text" value="30"/> (1~30 )</p> <p>GOP Length : <input type="text" value="30"/> (1~120 )</p> <p><input type="button" value="Apply"/></p> <p>* "Apply" will apply changes for all three streams settings to the camera.</p>	Video Compression: H.265 / H.264	Select the desired compression.
	Resolution	Select the desired resolution. Options vary based on the sensor resolution being used.
	Enable SNAPstream+™	Enable the SNAPstream+™ feature on the camera. This feature utilizes both Smart GOP and Smart ROI to reduce bitrate without impacting the image quality. Smart GOP sets GOP to automatically increase when no moving objects are detected. Smart ROI will increase the bitrate of moving objects and make them clearer.
	Variable Bitrate	Maintains the Quality settings configured. There may be variation in the bit rate output from the camera when using this mode.
	Maximum Bitrate	Maintains variable bit rate control and maintains the bitrate under the rate limit you choose. It can be set from 64 kbps to 8000 kbps.
	Frames Per Seconds	Frame rate adjustment for the camera video stream.  <b>NOTE:</b> For 5MP model, FPS will be up to 50% of specified FPS if WDR is enabled. <b>NOTE:</b> For 5MP model, if one stream is set to full resolution and another one is set to full or half resolution, the maximum FPS of the main and sub stream is up to 15 FPS.
	GOP Length	Specifies how many frames exist between two consecutive I-Frames.

<p><b>Sub Stream</b></p> <p>Video Compression</p> <p><input type="radio"/> H.265</p> <p><input checked="" type="radio"/> H.264</p> <p>Resolution</p> <p><input type="radio"/> 1920x1080</p> <p><input checked="" type="radio"/> 1280x720</p> <p><input type="radio"/> 960x540</p> <p><input type="radio"/> 640x480</p> <p><input type="radio"/> 640x360</p> <p><input type="radio"/> 320x240</p> <p><input type="checkbox"/> Enable SNAPstream+™</p> <p><input type="radio"/> Variable Bitrate</p> <p><input checked="" type="radio"/> Maximum Bitrate</p> <p>(64-8000 kbps): <input type="text" value="4000"/></p> <p>H.264 Quality (1..10) : <input type="text" value="4"/></p> <p><small>* 10 - lowest quality, 1 - highest quality</small></p> <p><input type="radio"/> Constant Bitrate</p> <p>Bitrate : <input type="text" value="4000"/> (64~8000 kbps)</p> <p>Frames Per Seconds: <input type="text" value="30"/> (1~30 )</p> <p><small>* If both Main Stream and Sub Stream set to 1080P, the Third Stream will be terminated, and the FPS of Sub Stream can be set up to 20fps.</small></p> <p>GOP Length : <input type="text" value="30"/> (1~120 )</p>	Video Compression: H.265 / H.264	Select the desired compression.
	Resolution	Select the desired resolution. Options vary based on the sensor resolution being used.
	Enable SNAPstream+™	Enable the SNAPstream+™ feature on the camera. This feature utilizes both Smart GOP and Smart ROI to reduce bitrate without impacting the image quality. Smart GOP sets GOP to automatically increase when no moving objects are detected. Smart ROI will increase the bitrate of moving objects and make them clearer.
	Frames Per Seconds	Frame rate adjustment for the camera video stream.
	GOP Length	Specifies how many frames exist between two consecutive I-Frames.
<p><b>Third Stream</b></p> <p>Video Compression</p> <p><input checked="" type="radio"/> MJPEG</p> <p>Resolution</p> <p><input checked="" type="radio"/> 640x360</p> <p>Frames Per Seconds: <input type="text" value="30"/> (1~30 )</p> <p>Quality</p> <p><input type="radio"/> Low</p> <p><input type="radio"/> Mid</p> <p><input checked="" type="radio"/> High</p>	Resolution	The third stream is designed for the live view on web interface, and the only option for Resolution is VGA.
	Frames Per Seconds	Frame rate adjustment for the camera video stream.
	Quality: <b>Low / Mid / High</b>	Adjusts the compression level for JPEG images
	Video Compression: <b>MPJEG</b>	The third stream is designed for the live view on web interface, and the only option of Video Compression is MPJEG.

<h2 style="text-align: center;">Audio</h2>		
<p><input checked="" type="checkbox"/> <b>Audio In</b> <b>Volume</b></p> <p><input type="radio"/> High <input checked="" type="radio"/> Middle <input type="radio"/> Low</p> <p><b>Encoding</b></p> <p><input checked="" type="radio"/> u-Law <input type="radio"/> A-Law</p>	<p>Audio In</p> <p>Audio Out</p> <p>Volume</p> <p>Encoding</p>	<p>Enables the Audio In / Audio Out features on the camera.</p> <p>Specifies the volume level of Audio In / Audio Out: High, Middle, or Low.</p> <p>Specifies the encoding algorithm: A-Law or U-Law.</p>

# Focus

Image
Video & Audio
Focus
Network
Privacy Mask
Event
System Options
Administration
About
Support
Model: AV02CLB-100  
Firmware: 35110.4  
MAC: 00-1a-07-18-b4-e1

Menu	Feature	Description
<div style="text-align: center; font-size: 1.2em; font-weight: bold; color: #0056b3;">Focus</div> <hr/> <p>Focus : <input style="width: 80px; height: 20px;" type="text"/></p> <div style="display: flex; justify-content: space-around; margin-bottom: 5px;"> <span style="border: 1px solid #ccc; padding: 2px 10px; border-radius: 3px;">+20</span> <span style="border: 1px solid #ccc; padding: 2px 10px; border-radius: 3px;">+5</span> <span style="border: 1px solid #ccc; padding: 2px 10px; border-radius: 3px;">+1</span> </div> <div style="display: flex; justify-content: space-around; margin-bottom: 5px;"> <span style="border: 1px solid #ccc; padding: 2px 10px; border-radius: 3px;">-20</span> <span style="border: 1px solid #ccc; padding: 2px 10px; border-radius: 3px;">-5</span> <span style="border: 1px solid #ccc; padding: 2px 10px; border-radius: 3px;">-1</span> </div> <div style="margin-bottom: 5px;"> <span style="border: 1px solid #ccc; padding: 2px 15px; border-radius: 3px; display: inline-block;">Full-range Focus</span> </div> <div style="margin-bottom: 10px;"> <span style="border: 1px solid #ccc; padding: 2px 10px; border-radius: 3px; display: inline-block;">Stop</span> </div> <div style="text-align: center;"> <span style="border: 1px solid #ccc; padding: 2px 20px; border-radius: 3px; display: inline-block;">Reset Focus Position</span> </div>	<p>Manual Focus: +20, +5, +1, -20, -5, -1</p> <p>Full-range Focus</p> <p>Stop</p> <p>Reset Focus Position</p>	<p>Number indicates the level of focusing in order to adjust the field-of-view.</p> <p>Full-range Focus button. The camera begins to autofocus with the lens stopping at the best overall point of focus.</p> <p>Stops any command in progress.</p> <p>Resets Focus lens groups to zero position.</p>

# Network

AV COSTAR

 Model AV02CLB-100  
 Firmware 35110.4  
 MAC 00-1a-07-18-b4-e1
 

Image
Video & Audio
Focus
Network
Privacy Mask
Event
System Options
Administration
About
Support

Menu	Feature	Description
<div style="text-align: center; font-size: 1.5em; color: #0056b3; margin-bottom: 10px;">Network</div> <hr style="border: 0.5px solid #ccc; margin-bottom: 10px;"/> <p><b>IP Assignment</b></p> <p><input checked="" type="checkbox"/> DHCP</p> <p>IP Address: <input style="width: 100px;" type="text" value="192.168.0.183"/></p> <p>Subnet Mask: <input style="width: 100px;" type="text" value="255.255.255.0"/></p> <p>Default Gateway: <input style="width: 100px;" type="text" value="192.168.0.1"/></p> <p><b>Port</b></p> <p>HTTP: <input style="width: 40px;" type="text" value="80"/> (80,1024~65535)</p> <p>Second HTTP Port: <input style="width: 40px;" type="text" value="8080"/> (8080,1024~65535)</p> <p>HTTPS: <input style="width: 40px;" type="text" value="443"/> (443,1024~65535)</p> <p><b>DNS</b></p> <p>Primary DNS: <input style="width: 100px;" type="text" value="192.168.0.1"/></p> <p>Secondary DNS: <input style="width: 100px;" type="text"/></p>	<p>IP Assignment:</p> <ul style="list-style-type: none"> <li>DHCP</li> <li>IP Address</li> <li>Subnet Mask</li> <li>Default Gateway</li> </ul>	<p><b>DHCP:</b> If checked, the camera will attempt to obtain its IP address from the DHCP server available on the network.</p> <p><b>IP Address:</b> Sets the current IP address of the camera.</p> <p><b>Subnet Mask:</b> Once set, the camera will use these mask bits to determine if a destination is from a different network.</p> <p><b>Default Gateway:</b> Once set, the camera will send network traffic to the specified gateway if the destination is on a different network.</p>
	<p>Port:</p> <ul style="list-style-type: none"> <li>HTTP</li> <li>Second HTTP Port</li> <li>HTTPS</li> </ul>	<p><b>HTTP:</b> The port default is 80. It is used to access the camera via the web browser.</p> <p><b>Second HTTP Port:</b> Sets an alternative HTTP port. This port can be useful when the standard HTTP port (80) is not appropriate for this camera.</p> <p><b>HTTPS:</b> The port default is 443. It can be used when you use HTTPS.</p>
	<p>Port:</p> <ul style="list-style-type: none"> <li>Primary DNS</li> <li>Secondary DNS</li> </ul>	<p>Configures the Primary and Secondary DNS.</p>

<p><b>IPv6 Settings</b></p> <p><input type="checkbox"/> Enable IPv6</p> <p>Link-Local:</p> <p>IPv6 Address: <input type="text"/></p> <p>Address Prefix: <input type="text" value="64"/> (0~127)</p> <p>Default Route: <input type="text"/></p> <p><input type="checkbox"/> Router Advertisement</p> <p>DNS: <input type="text"/></p>	<p>IPv6 Settings:</p> <ul style="list-style-type: none"> <li>• Enable IPv6</li> <li>• IPv6 Address</li> <li>• Address Prefix</li> <li>• Default Route</li> <li>• Router Advertisement</li> <li>• DNS</li> </ul>	<p>Enable IPv6: Enables IPv6 function. Manually configures IPv6 address, Address prefix, Default route, and DNS server address.</p> <p>Router Advertisement: Enables Router Advertisement</p>
<p style="text-align: center;"><b>QoS</b></p> <p><input type="checkbox"/> Enable QoS</p> <p>Video QoS (0-63) : <input type="text" value="34"/></p> <p>Management DSCP (0-63) : <input type="text" value="0"/></p> <p><input type="button" value="Apply"/></p>	<p>QoS Enable</p>	<p>Enables quality of service.</p>
	<p>QoS Video</p>	<p>Sets DSCP value for video traffic.</p>
	<p>Management DSCP</p>	<p>Sets DSCP value for non-video traffic.</p>
<p style="text-align: center;"><b>UPnP</b></p> <p><input checked="" type="checkbox"/> Enable UPnP</p> <p><input type="button" value="Apply"/></p>	<p>Enable UPnP</p>	<p>Enables Universal Plug and Play function.</p>

<p style="text-align: center;"><b>RTSP</b></p> <p>Port : <input type="text" value="554"/> (554, 1025~65535)</p> <p><input checked="" type="checkbox"/> Enable RTSP Unicast Stream1</p> <p><input checked="" type="checkbox"/> Enable RTSP Stream1 Metadata</p> <p>Path1 : <input type="text" value="stream1"/></p> <p>Link for external media players : <input type="text" value="rtsp://192.168.0.183:554/stream1"/></p> <p><input checked="" type="checkbox"/> Enable RTSP Unicast Stream2</p> <p><input checked="" type="checkbox"/> Enable RTSP Stream2 Metadata</p> <p>Path2 : <input type="text" value="stream2"/></p> <p>Link for external media players : <input type="text" value="rtsp://192.168.0.183:554/stream2"/></p> <p><input checked="" type="checkbox"/> Enable RTSP Unicast Stream3</p> <p><input checked="" type="checkbox"/> Enable RTSP Stream3 Metadata</p> <p>Path3 : <input type="text" value="stream3"/></p> <p>Link for external media players : <input type="text" value="rtsp://192.168.0.183:554/stream3"/></p>	<p>Enable RTSP Unicast Stream</p> <p>Enable RTSP Stream metadata</p> <p>Path</p> <p>Link for external media players</p> <p>Enable RTSP Multicast Stream</p>	<p>Enables RTSP Unicast for stream 1 (Main stream), stream 2 (Sub Stream), and stream 3 (Third Stream)</p> <p>Enables RTSP stream metadata for stream 1 (Main stream), stream 2 (Sub Stream), and stream 3 (Third Stream)</p> <p>Configures the pathname for each stream.</p> <p>Copies the link from here for external media players</p> <p>Enables RTSP Multicast stream for stream 1 (Main stream), stream 2 (Sub Stream), and stream 3 (Third Stream)</p>
	<p>Always Multicast</p>	<p>Enables the video streams to start multicast streaming without using RTCP</p>
	<p>Video IP Video Port</p>	<p>Configures the multicast address and the port number to stream video.</p>
	<p>Audio IP Audio Port</p>	<p>Configures the multicast address and the port number to stream audio. *This function's support depends on the model</p>

<p style="text-align: center;"><b>Multicast</b></p> <p><b>Multicast Stream1</b></p> <p><input checked="" type="checkbox"/> Enable RTSP Multicast Stream</p> <p><input type="checkbox"/> Always Multicast</p> <p>Video IP : <input type="text" value="225.26.146.175"/></p> <p>Video Port : <input type="text" value="5000"/> (1025~65535)</p> <p>Audio IP : <input type="text" value="226.26.146.175"/></p> <p>Audio Port : <input type="text" value="5002"/> (1025~65535)</p> <p>Meta IP : <input type="text" value="227.26.146.175"/></p> <p>Meta Port : <input type="text" value="5004"/> (1025~65535)</p> <p>Path : <input type="text" value="stream1m"/></p> <p>TTL : <input type="text" value="255"/> (1~255)</p>	Meta IP Meta Port	Configures the multicast address and the port number to the HTML meta.
	Path	Configures the URL address of the video stream.
	TTL	Configures the time-to-live threshold of the multicast datagram before it is discarded by the router.
<p style="text-align: center;"><b>DDNS</b></p> <p><input type="checkbox"/> Enable DDNS</p> <p>Host Name : <input type="text"/></p> <p>DDNS Server : <input type="text" value="DynDNS"/> ▼</p> <p>User Name : <input type="text"/></p> <p>Password : <input type="text"/></p> <p>Password Confirmation : <input type="text"/></p>	Enable DDNS	Enables DDNS service
	Host Name	Specifies the Host name registered with the DDNS server
	DDNS Sever	Selects one of the pubic DDNS severs from the dropdown menu. Options are DynDNS, NO-IP, and Twi-DNS.
	User Name	Specifies the user name of the DDNS account.
	Password	Specifies the password of the DDNS account.
	Password Confirmation	Confirms the password of the DDNS account.

<div style="text-align: center; font-size: 24px; font-weight: bold; color: #0056b3;">SNMP</div> <input checked="" type="radio"/> No SNMP Server <input type="radio"/> SNMP V2c Community String : <input type="text" value="public"/> <b>Trap Configuration</b> Address : <input type="text" value="192.168.1.200"/> Community String : <input type="text" value="public"/> <input type="radio"/> SNMP V3 SNMP User : <input type="text" value="initial"/> Authentication : <input type="text" value="None"/> Password : <input type="password"/> Privacy : <input type="text" value="None"/> Password : <input type="password"/> <b>Trap Configuration</b> Address : <input type="text" value="192.168.1.200"/> <div style="text-align: center; margin-top: 10px;"> <input type="button" value="Download MIB"/> </div> <div style="text-align: center; margin-top: 10px;"> <input type="button" value="Apply"/> </div>		
	No SNMP Sever	Disables SNMP function
	SNMP v2c	Enables SNMP version 2 support
	Community String	Specifies the name of the community to access to SNMP information.
	Trap Configuration: Address Community String	Specifies the destination IP address to send SNMP trap messages.
	SNMP v3	Enables SNMP version 3 support.
	SNMP User	Specifies the user name of the SNMP v3.
	Authentication Password	Selects one of the Authentication modes from the dropdown menu. Options are None, MD5, and SHA. Specifies the Password for the Authentication.
	Privacy Password	Selects one of the encryption methods for SNMP v3 from the dropdown menu. Options are DES and AES. Specifies the Password for the encryption.
	Trap Configuration: Address	Specifies the destination IP address to send SNMP trap messages.
	Download MIB	Clicks to download MIB file for SNMP.

<p style="text-align: center;"><b>SSL</b></p> <p>Mode : <input type="radio"/> Disable <input checked="" type="radio"/> Optional</p> <p>Certificate : No certificate has been installed.</p> <p>Action : <input type="button" value="Install New Certificate"/></p> <p>Key PEM file :</p> <p><input type="button" value="Choose File"/> No file chosen</p> <p><input type="button" value="Upload"/></p> <p>Certificate PEM file :</p> <p><input type="button" value="Choose File"/> No file chosen</p> <p><input type="button" value="Upload"/></p> <p><input type="button" value="Apply"/></p>	<p>Mode</p>	<p>Disable: Support for HTTP only. (Optional) Support for HTTP and HTTPs both.</p>
	<p>Certificate</p>	<p>Shows the current status of the Certificate</p>
	<p>Install New Certificate Key PEM file Certificate PEM file</p>	<p>1. Locate Key PEM file and Certificate PEM file and click Upload. Click Install New Certificate to upload the Certificate.</p>
	<p>Enable</p>	<p>Enables FTP access to the camera.</p> <p>2. <b>NOTE:</b> This function is only available when a SD card is installed. You can access files in the SD card via FTP.</p>
<p style="text-align: center;"><b>FTP</b></p> <p><input type="checkbox"/> Enable</p> <p>User name : adminftp</p> <p>Password : <input type="password" value="...."/></p> <p>Confirm : <input type="password" value="...."/></p> <p>Max. Connection (1~10) : <input type="text" value="10"/></p> <p><input type="button" value="Apply"/></p>	<p>Password Confirm</p>	<p>Specifies and confirms the password to access the FTP.</p>
	<p>Max. Connection</p>	<p>Specifies the maximum number of FTP connections to the IP camera.</p>

<p style="text-align: center;"><b>802.1x</b></p> <p>Protocol :</p> <p><input type="button" value="Apply"/></p> <div style="border: 1px solid black; padding: 2px;"><p>NONE ▼</p><p>NONE</p><p>EAP-MD5</p><p>EAP-TLS</p><p>EAP-TTLS</p><p>EAP-PEAP</p></div>	<p>Protocol</p>	<p>The default is None to disable 802.1x functions. You can select one of the protocol options from the dropdown menu. The supported protocols are EAP-MD5, EAP-TLS, EAP-TTLS or EAP-PEAP. After the protocol has been selected, manually configure the username, password, and other required information.</p>
---	-----------------	---

# Privacy Mask



- Image
- Video & Audio
- Focus
- Network
- Privacy Mask**
- Event
- System Options
- Administration
- About
- Support

Model AV02CLB-100  
Firmware 35110.4  
MAC 00-1a-07-18-b4-e1

Menu	Feature	Description
<h2>Privacy Mask</h2> <hr/> <p><input type="checkbox"/> Enable Privacy Mask</p> <p>* Left click and drag to set mask * Right click and drag to erase mask <i>Note: It might take a few seconds for a privacy mask to show on the video stream.</i></p>	<p>Enable Privacy Mask</p> <hr/> <p>Drag mouse to: Mask Unmask</p>	<p>Creates a privacy mask on the image so the selected areas will not be visible.</p> <hr/> <p>Select Mask to add privacy masks or Select Unmask to remove privacy masks.</p>

# Event



Menu	Feature	Description
<p><b>Motion Detection</b> ▾</p> <p><input checked="" type="checkbox"/> Enable <input type="checkbox"/> Extended</p> <p>Zone Size: <input type="text" value="11"/></p> <p>Object Size Sensitivity: <input type="text" value="2"/></p> <p>Movement Duration Factor: <input type="text" value="7"/></p> <p>Motion Sensitivity %: <input type="text" value="80"/></p> <p>* Left click and move to select window to set mask. * Right click and move to select window to reset mask.</p>	Enable motion detection	Turn on and off on-camera motion detection.
	Enable extended motion detection	Enables the extended motion detection and motion detection zones with an increase from default 64 to 1024 for enhanced motion detection sensitivity.
	Select channel	Select the desired channel to apply motion detection.
	Zone Size	Adjusts the size of motion detection zones.
	Object Size Sensitivity	Sets the size of each zone displayed by the motion detection grid. Contains sub zones where the number of sub zones is set by setting the zone size up to 32x32 (pixels). This setting configures the sensitivity of the motion detection to the size of objects in the image moving through the zone. Higher values will trigger motion only for larger objects moving through the zone, and lower values will cause detection of smaller objects in the zone (increasing sensitivity to smaller size objects moving through the image).
	Movement Duration Factor	Sets the sensitivity to brightness changes between dark and light objects within each grid zone. As an example, "Object Size Sensitivity" will set the size of the object detected within the zone, and "Movement Duration Factor" sets the duration that movement must be maintained to trigger motion detection. Lower settings can increase false motion alarms caused by image noise; higher settings will require more movement to trigger a motion event.
	Motion Sensitivity	Sets the sensitivity to sudden overall brightness changes in the image.

<h3 style="text-align: center;">Alarm Handler</h3> <p style="text-align: right;">▼</p> <p><input checked="" type="checkbox"/> Enable Alarm Detection</p> <p style="text-align: center;"><a href="#">Alarm Schedule</a></p>	<p>Enable Alarm Detection</p>	<p>Enables Alarm Detection (Alarm In) function.</p>
	<p>Alarm Schedule</p>	<p>Configures the alarm schedule by holding down the mouse button and clicking the time block to enable the schedule settings on the selected time. A light blue color on the time block indicates that the alarm schedule is enabled, while a light grey color indicates that the alarm schedule is disabled.</p> <p>Alternatively, you can manually enter the numbers to configure the hours and minutes for the “start” and “end” of the day.</p> <p>S: Click “S” to set up a 24-hour schedule on a particular day. D: Click “D” to clear the previous schedule on a particular day.</p>
<h3 style="text-align: center;">Digital I/O</h3> <p style="text-align: right;">▼</p> <p><input type="checkbox"/> Trigger Alarm Detection</p> <p><input type="checkbox"/> Trigger Motion Detection</p> <p><input type="checkbox"/> Trigger Tamper Detection</p> <p><input type="checkbox"/> Trigger Network Failure</p> <p>Type <span style="border: 1px solid black; padding: 2px;">N.O.</span> ▼</p> <p>Off Time <span style="border: 1px solid black; padding: 2px;">0</span> (0~30s)</p>	<p>Trigger Alarm Detection</p>	<p>When a signal is detected from Alarm in the Alarm out will be triggered.</p>
	<p>Trigger Motion Detection</p>	<p>When a motion event is detected the Alarm out will be triggered.</p>
	<p>Trigger Tamper Detection</p>	<p>When a tamper event is detected, the Alarm out will be triggered.</p>
	<p>Trigger Network Failure</p>	<p>When a network failure event is detected the Alarm out will be triggered.</p>
	<p>Type</p>	<p>Selects the type: N.O (Normal Open) or N.C (Normal Close)</p>
	<p>Off Time</p>	<p>Specifies the alarm duration</p>
<h3 style="text-align: center;">Tamper Detection</h3> <p style="text-align: right;">▼</p> <p><input type="checkbox"/> Enable Tampering Detection</p> <p style="text-align: center;"><a href="#">Tampering Schedule</a></p> <p>Sensitivity <span style="border: 1px solid black; padding: 2px;">Medium</span> ▼</p> <p style="text-align: center;"><a href="#">Apply</a></p>	<p>Select channel</p>	<p>Select the desired channel to enable tampering detection.</p>
	<p>Enable Tampering Detection</p>	<p>Enables Tampering Detection function.</p>
	<p>Tampering Schedule</p>	<p>Configures the alarm schedule by holding down the mouse button and clicking the time block to enable the schedule settings for the selected time. A light blue color on the time block indicates that the alarm schedule is enabled, while a light grey color indicates that the alarm schedule is disabled.</p>

		<p>Alternatively, you can manually enter the numbers to configure the hours and minutes for the “start” and “end” of the day.</p> <p>S: Click “S” to set up a 24-hour schedule for a particular day.</p> <p>D: Click “D” to clear the previous schedule for a particular day.</p>
	Sensitivity	<p>Configures the sensitivity level of Tamper Detection: <b>High</b>, <b>Medium</b>, and <b>Low</b>.</p>
<p><b>Network Failure</b> ▼</p> <p><input type="checkbox"/> Enable Network Failure Detection</p>	Enable Network Failure	Enable network failure detection.
<p><b>FTP Upload Handler</b> ▼</p> <p><b>Remote Server</b></p> <p>Host Address : <input type="text"/></p> <p>Port : <input type="text" value="21"/> (21, 1025~65535)</p> <p>Username : <input type="text"/></p> <p>Password : <input type="text"/></p>	<p>Remote Server</p> <p>Host Address</p> <p>Port</p> <p>Username</p> <p>Password</p>	<p><b>Host Address:</b> Specifies the host name or IP address of the FTP server.</p> <p><b>Port:</b> Specifies the port number of the FTP server.</p> <p><b>Username:</b> Specifies the login username of the FTP server.</p> <p><b>Password:</b> Specifies the login password of the FTP server.</p>
<p><b>FTP Upload Handler</b></p> <p><input type="checkbox"/> Enable Trigger Event</p> <ul style="list-style-type: none"> <li><input type="radio"/> Trigger Alarm Detection</li> <li><input type="radio"/> Trigger Motion Detection</li> <li><input type="radio"/> Trigger Tampering Alarm</li> <li><input type="radio"/> Trigger Scheduled</li> </ul>	<p>FTP Upload Handler</p> <p>Enable Trigger Event</p>	<p>Enables and selects a desired trigger source. The options are Trigger Alarm Detection*, Trigger Motion Detection, Trigger Tampering Alarm, and Trigger Scheduled.</p> <p><i>*This function's support depends on the model</i></p>

	SMTP Notification Handler	<p>From: Specifies the email address of the sender</p> <p>Selects a desired trigger source. The options are Trigger Alarm Detection, Trigger Motion Detection, and Trigger Tampering Alarm.</p>
--	---------------------------	---

<h2 style="text-align: center;">SMTP Notification <span style="float: right;">▼</span></h2> <p><b>SMTP Notification Handler</b></p> <p>From : <input type="text"/></p> <p><input type="checkbox"/> Trigger Alarm Detection</p> <p><input type="checkbox"/> Trigger Motion Detection</p> <p><input type="checkbox"/> Trigger Tampering Alarm</p> <p><b>SMTP Server</b></p> <p>Host Address : <input type="text"/></p> <p>Port : <input type="text" value="25"/> (1~65535)</p> <p>Username : <input type="text"/></p> <p>Password : <input type="text"/></p> <p>Authentication : <input type="text" value="NO_AUTH"/> ▼</p> <p><b>Recipient List</b></p> <table border="1"> <thead> <tr> <th>Enable</th> <th>No</th> <th>Email</th> <th>Alarm</th> <th>Motion</th> <th>Tampering</th> </tr> </thead> <tbody> <tr><td><input type="checkbox"/></td><td>1</td><td><input type="text"/></td><td><input type="checkbox"/></td><td><input type="checkbox"/></td><td><input type="checkbox"/></td></tr> <tr><td><input type="checkbox"/></td><td>2</td><td><input type="text"/></td><td><input type="checkbox"/></td><td><input type="checkbox"/></td><td><input type="checkbox"/></td></tr> <tr><td><input type="checkbox"/></td><td>3</td><td><input type="text"/></td><td><input type="checkbox"/></td><td><input type="checkbox"/></td><td><input type="checkbox"/></td></tr> <tr><td><input type="checkbox"/></td><td>4</td><td><input type="text"/></td><td><input type="checkbox"/></td><td><input type="checkbox"/></td><td><input type="checkbox"/></td></tr> <tr><td><input type="checkbox"/></td><td>5</td><td><input type="text"/></td><td><input type="checkbox"/></td><td><input type="checkbox"/></td><td><input type="checkbox"/></td></tr> <tr><td><input type="checkbox"/></td><td>6</td><td><input type="text"/></td><td><input type="checkbox"/></td><td><input type="checkbox"/></td><td><input type="checkbox"/></td></tr> <tr><td><input type="checkbox"/></td><td>7</td><td><input type="text"/></td><td><input type="checkbox"/></td><td><input type="checkbox"/></td><td><input type="checkbox"/></td></tr> <tr><td><input type="checkbox"/></td><td>8</td><td><input type="text"/></td><td><input type="checkbox"/></td><td><input type="checkbox"/></td><td><input type="checkbox"/></td></tr> <tr><td><input type="checkbox"/></td><td>9</td><td><input type="text"/></td><td><input type="checkbox"/></td><td><input type="checkbox"/></td><td><input type="checkbox"/></td></tr> <tr><td><input type="checkbox"/></td><td>10</td><td><input type="text"/></td><td><input type="checkbox"/></td><td><input type="checkbox"/></td><td><input type="checkbox"/></td></tr> </tbody> </table>	Enable	No	Email	Alarm	Motion	Tampering	<input type="checkbox"/>	1	<input type="text"/>	<input type="checkbox"/>	<input type="checkbox"/>	<input type="checkbox"/>	<input type="checkbox"/>	2	<input type="text"/>	<input type="checkbox"/>	<input type="checkbox"/>	<input type="checkbox"/>	<input type="checkbox"/>	3	<input type="text"/>	<input type="checkbox"/>	<input type="checkbox"/>	<input type="checkbox"/>	<input type="checkbox"/>	4	<input type="text"/>	<input type="checkbox"/>	<input type="checkbox"/>	<input type="checkbox"/>	<input type="checkbox"/>	5	<input type="text"/>	<input type="checkbox"/>	<input type="checkbox"/>	<input type="checkbox"/>	<input type="checkbox"/>	6	<input type="text"/>	<input type="checkbox"/>	<input type="checkbox"/>	<input type="checkbox"/>	<input type="checkbox"/>	7	<input type="text"/>	<input type="checkbox"/>	<input type="checkbox"/>	<input type="checkbox"/>	<input type="checkbox"/>	8	<input type="text"/>	<input type="checkbox"/>	<input type="checkbox"/>	<input type="checkbox"/>	<input type="checkbox"/>	9	<input type="text"/>	<input type="checkbox"/>	<input type="checkbox"/>	<input type="checkbox"/>	<input type="checkbox"/>	10	<input type="text"/>	<input type="checkbox"/>	<input type="checkbox"/>	<input type="checkbox"/>	<p>SMTP Server</p> <p>Host Address</p> <p>Port</p> <p>Username</p> <p>Password</p> <p>Authentication</p> <p>Recipient List</p>	<p><b>Host Address:</b> Specifies the host name or IP address of the SMTP server.</p> <p><b>Port:</b> Specifies the port number of the SMTP server.</p> <p><b>Username:</b> Specifies the login username of the SMTP server.</p> <p><b>Password:</b> Specifies the login password of the SMTP server.</p> <p><b>Authentication:</b> Specifies the authentication mode of the SMTP sever. The options are NO_AUTH, SMTP_PLAIN, LOGIN and TLS_TLS.</p> <p>Specifies the email addresses to send the email notification when selected events are triggered by Alarm, Motion, or Tamper. A maximum of 10 email addresses can be configured.</p>
Enable	No	Email	Alarm	Motion	Tampering																																																															
<input type="checkbox"/>	1	<input type="text"/>	<input type="checkbox"/>	<input type="checkbox"/>	<input type="checkbox"/>																																																															
<input type="checkbox"/>	2	<input type="text"/>	<input type="checkbox"/>	<input type="checkbox"/>	<input type="checkbox"/>																																																															
<input type="checkbox"/>	3	<input type="text"/>	<input type="checkbox"/>	<input type="checkbox"/>	<input type="checkbox"/>																																																															
<input type="checkbox"/>	4	<input type="text"/>	<input type="checkbox"/>	<input type="checkbox"/>	<input type="checkbox"/>																																																															
<input type="checkbox"/>	5	<input type="text"/>	<input type="checkbox"/>	<input type="checkbox"/>	<input type="checkbox"/>																																																															
<input type="checkbox"/>	6	<input type="text"/>	<input type="checkbox"/>	<input type="checkbox"/>	<input type="checkbox"/>																																																															
<input type="checkbox"/>	7	<input type="text"/>	<input type="checkbox"/>	<input type="checkbox"/>	<input type="checkbox"/>																																																															
<input type="checkbox"/>	8	<input type="text"/>	<input type="checkbox"/>	<input type="checkbox"/>	<input type="checkbox"/>																																																															
<input type="checkbox"/>	9	<input type="text"/>	<input type="checkbox"/>	<input type="checkbox"/>	<input type="checkbox"/>																																																															
<input type="checkbox"/>	10	<input type="text"/>	<input type="checkbox"/>	<input type="checkbox"/>	<input type="checkbox"/>																																																															

	Network Storage Handler	Enables and selects a desired trigger source. The options are Trigger Alarm Detection*, Trigger Motion Detection, Trigger Tampering Alarm, and Trigger Scheduled. <i>*This functions support depends on the model.</i>
	Recipient Setup Network Storage Status Network Address Folder Name Record Type	<b>Network Storage Status:</b> Displays the current status of the connection with the network storage server. (Status will display “Not Mounted” or “OK”) <b>Network Address:</b> Specifies the IP address of the network storage server. <b>Folder Name:</b> Specifies the folder name on the network storage server. <b>Recording Type:</b> Specifies the desired action when an event is triggered. The options are Snapshot and Video.
	Login Certificate	Specifies the login Username and Password for the network storage sever.



<h2 style="text-align: center;">SD Card <span style="float: right;">▼</span></h2> <p><input type="checkbox"/> Enable</p> <ul style="list-style-type: none"><li><input type="radio"/> Trigger Alarm Detection</li><li><input type="radio"/> Trigger Motion Detection</li><li><input type="radio"/> Trigger Tampering Alarm</li><li><input type="radio"/> Manual Record</li><li><input type="radio"/> Network Failure</li></ul> <p><b>SD Card Information</b></p> <p>Available Storage    0 MBytes</p> <p><input type="button" value="Format SD Card"/></p> <p>Usage                0% ( 0 / 0 MBytes)</p> <p>Status               not_mounted</p> <p>Overwrite when storage full <input checked="" type="checkbox"/></p> <p>Record Type    <input type="text" value="Video"/></p>	<p>SD Card Information</p> <p>Available Storage</p> <p>Format SD Card</p> <p>Usage</p> <p>Status</p> <p>Overwrite when storage full</p> <p>Record Type</p>	<p><b>Available Storage:</b> Displays the available storage of the SD card if it is installed.</p> <p><b>Format SD Card:</b> Erases all the data stored on the SD Card.</p> <p><b>Usage:</b> Displays the total storage that has been used now.</p> <p><b>Status:</b> Displays the status whether the SD card is installed or not. (not mounted or ok)</p> <p><b>Overwrite when storage full:</b> Enables overwriting the SD card if the storage is full.</p> <p><b>Recording Type:</b> Specifies the desired action to record a stream. The options are Snapshot and Video.</p>
--	--	--

# System Options

Image
Video & Audio
Focus
Network
Privacy Mask
Event
System Options
Administration
About
Support

 Model AV02CLB-100  
 Firmware 3S110.4  
 MAC 00-1a-07-18-b4-e1

Menu	Feature	Description
<p style="text-align: center;"><b>System Options</b></p> <hr/> <p><b>Firmware Upgrade</b></p> <p>Please select a file to update:</p> <p>File Name : <input type="button" value="Choose File"/> No file chosen</p> <p><input type="button" value="Upgrade"/></p> <p><b>Configuration Management</b></p> <p>Importing : <input type="button" value="Choose File"/> No file chosen</p> <p><input type="button" value="Import"/></p> <p>Exporting : <input type="button" value="Export"/></p> <p><b>Download Log</b></p> <p><input type="button" value="Download"/></p> <p><b>Reboot &amp; Restore Settings</b></p> <p><input type="button" value="Reboot the Camera"/></p> <p><input type="button" value="Restore to Factory Default Settings Except Network Settings"/></p> <p><input type="button" value="Restore to Factory Default Settings"/></p>	<p>Firmware Upgrade</p> <p>Download Log</p> <ul style="list-style-type: none"> <li>• Reboot the Camera</li> <li>• Restore Factory Default Settings Except Network Settings</li> <li>• Restore to Factory Default Settings</li> </ul>	<p>Click "Choose File" to choose the firmware upgrade file, and then click Upgrade.</p> <p>Records all the status information of the camera in list format. Downloads the log file to the computer as a text file.</p> <p><i><b>NOTE:</b> The log file is protected by a password. Please contact with AV Costar™ technical support team.</i></p> <p><b>Reboot the Camera:</b> Reboots the camera.</p> <p><b>Restore Factory Default Settings Except Network Settings:</b> Restores all settings to factory default except the network settings.</p> <p><b>Restore to Factory Default Settings:</b> Restores all settings to factory default.</p>
<p><b>Camera Name</b></p> <p><input type="text" value="AV2756DN-F-AF"/></p> <p><input type="button" value="save"/></p>	<p>Camera Name</p>	<p>Displays the information of the camera: Model Name, Firmware, MAC Address, and Serial Number.</p>

<h2 style="text-align: center;">Date/Time</h2> <p>Get Time from:</p> <p> <input type="radio"/> NTP Server  <input checked="" type="radio"/> Computer System         </p> <p>Time Zone: <span>America ▼</span> <span>Los_Angeles ▼</span></p> <p>NTP Server: <input type="text" value="0.north-america.pool.ntp"/></p> <p style="text-align: center;"> <input type="button" value="Apply NTP Server Configuration"/>  <input type="button" value="Update Time from the Computer"/> </p> <p> <small>* Select NTP Server option to synchronize time with the NTP server and enter server configuration.              * Select Computer System option to synchronize time with the computer system via camera web page.              * Set up appropriate gateway before configuring the NTP server.</small> </p>	<p>Date/Time</p> <ul style="list-style-type: none"> <li>Get Time from</li> <li>NTP Server</li> <li>Computer System</li> </ul>	<p><b>NTP Server:</b> Synchronizes the date/time information with defined NTP server. After setting up the desired Time zone and NTP Server, click “Apply NTP Server Configuration”.</p> <p><b>NOTE:</b> <i>Please make sure to set up appropriate gateway before configuring the NTP server.</i></p> <p><b>Computer System:</b> Synchronizes the date/time information with current computer’s date/time. Once this option is selected, click “Update Time from the computer”.</p>
	Time Zone	Specifies the country / city of the time zone from the drop-down menu.
	NTP Server	Specifies the desired NTP server

# Administration



Menu	Feature	Description
<p style="text-align: center;"><b>Administration</b></p> <hr/> <p><b>Access Control</b></p> <p>(Passwords can be up to 16 letters, digits and symbols, excluding following symbols for passwords without encoding # % &amp; ' " &lt; &gt; / [ ] { } _ ( ) = . + , )</p> <p><b>Administrator</b></p> <p>Username : admin</p> <p>Admin Password : <input type="password" value="••••••"/></p> <p>Confirmation : <input type="password" value="••••••"/></p> <p><input type="button" value="Set"/> <input type="button" value="Erase"/></p>	<p>Access Control</p> <p>Administrator</p> <ul style="list-style-type: none"> <li>• Username</li> <li>• Admin Password</li> <li>• Confirmation</li> <li>• Set/ Erase</li> </ul>	<p>Passwords can be up to 16 letters, digits and symbols, excluding the following symbols for passwords without encoding # % &amp; ' " &lt; &gt; / [ ] { } _ ( ) = . + ,</p> <p>Username: The username of Administrator is admin and cannot be changed.</p> <p><b>Admin:</b> includes full access to all camera settings and live video.</p> <p><b>Admin Password:</b> Specifies the password for the administrator.</p> <p><b>Confirmation:</b> Re-enters the password for the password validation.</p> <p><b>Set / Erase:</b> Saves or removes the password.</p> <p><b>NOTE:</b> <i>If admin password was set but has been lost, it can be erased by AV Costar Utility using the key file. Please contact AV Costar™ technical support to obtain the key file required to perform this function. Or, if the camera has a reset button, you can also reset it to Factory default to remove the password.</i></p>

<p><b>Viewer Management</b></p> <p>User List: <input type="text" value="test1"/></p> <p><input type="button" value="New User"/> <input type="button" value="Delete User"/></p> <p><u>User Information</u></p> <p>User Name: <input type="text"/></p> <p>Viewer Password : <input type="text"/></p> <p>Confirmation : <input type="text"/></p> <p>Access Level : <input type="radio"/> Admin <input type="radio"/> Viewer</p> <p><input type="button" value="Set"/></p>	<p>Viewer Management</p> <ul style="list-style-type: none"> <li>User List</li> <li>User Viewer Name</li> <li>User Viewer Password</li> <li>Confirmation</li> <li>Access Level</li> <li>Set/ Erase</li> </ul>	<p>User List: Displays current user accounts created on the camera. Clicks New User/ Delete User to create or remove a user account.</p> <p><b>User Viewer Name:</b> Specifies the user name. It must be at least five and up to sixteen characters.</p> <p><b>User Viewer Password:</b> Specifies the password for the viewer.</p> <p><b>Confirmation:</b> Re-enters the password for the password validation.</p> <p><b>Access Level:</b> Defines the authorization level for the user: Admin or Viewer.</p> <p>Set/ Erase: Save or removes the password.</p>
--	--	---

## About



- Image
- Video & Audio
- Focus
- Network
- Privacy Mask
- Event
- System Options
- Administration
- About
- Support

Model AV02CLB-100  
Firmware 35110.4  
MAC 00-1a-07-18-b4-e1

Menu	Feature	Description
<a href="#">About</a>	About	Model Name Firmware Serial Number MAC Address
Model Name : AV2756DN Firmware : 65350.02 Serial Number : T2001200006 MAC Address : 00-1a-07-1a-92-af		

# Support



Menu	Feature	Description
<b>Support</b> <hr/> <ul style="list-style-type: none"><li>• <a href="#">Resources</a></li><li>• <a href="#">Online Support Request</a></li><li>• <a href="#">Firmware Downloads</a></li><li>• <a href="#">Software Downloads</a></li><li>• <a href="#">Technical Updates</a></li><li>• <a href="#">Product Selector</a></li><li>• <a href="#">Downloads</a></li></ul>	Support	Provides several hyperlinks to get more information on the camera.

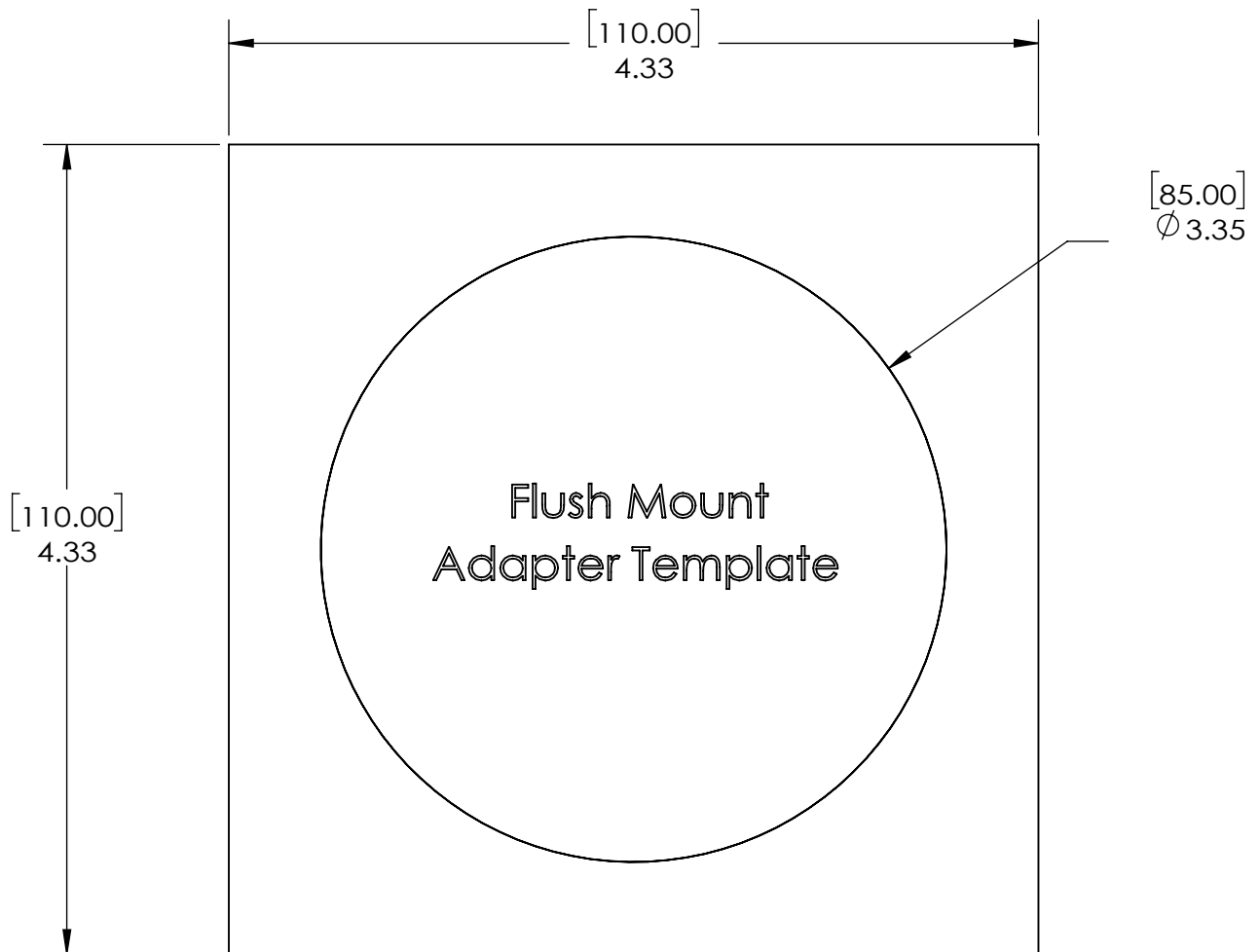

MicroDome Flush Mount  
Paper Size: Letter

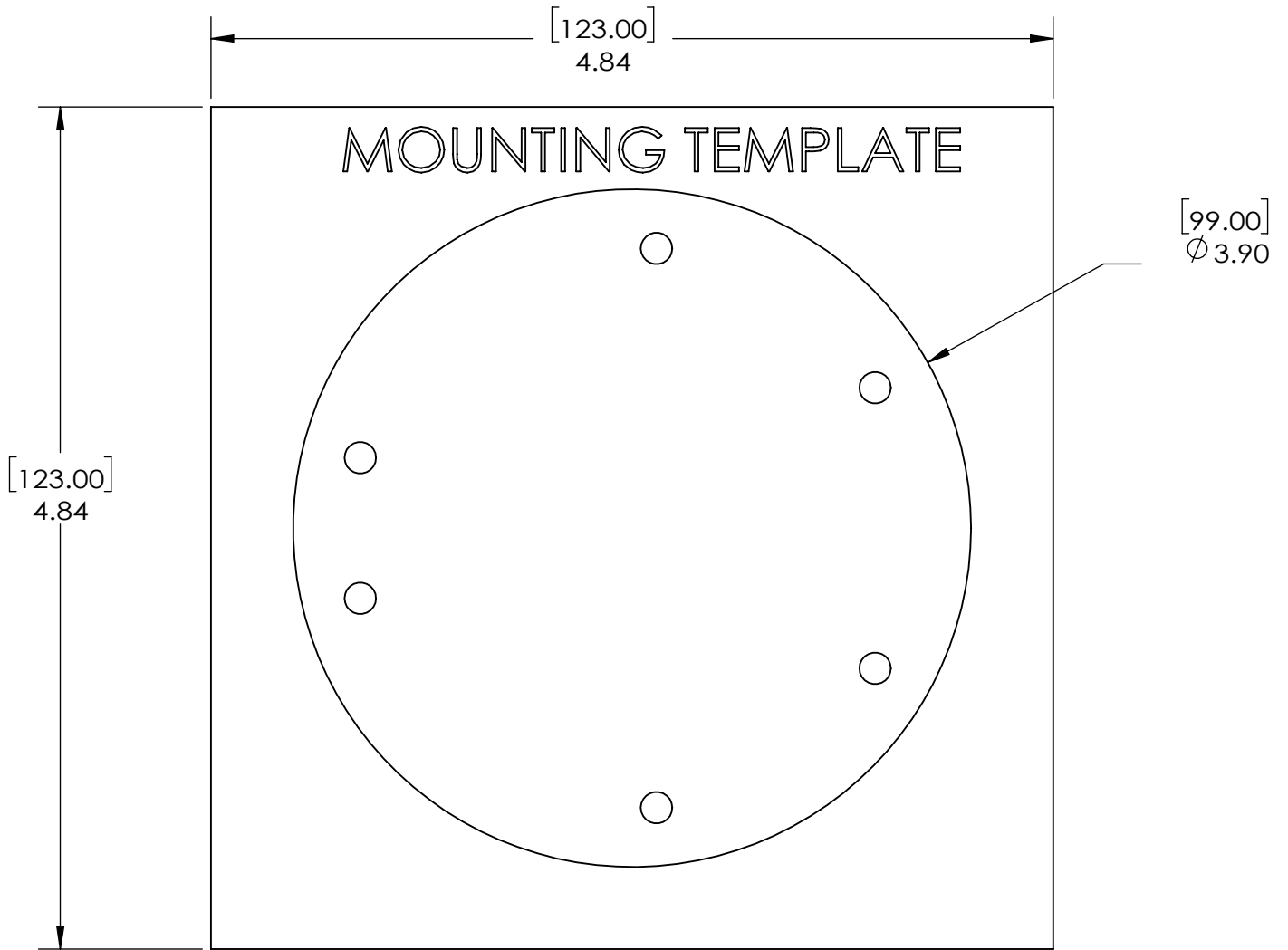

MicroDome Surface Mount  
Paper Size: Letter



© 2020 AV Costar™

All rights reserved. No part of this publication may be reproduced by any means without written permission from AV Costar™.

The information in this publication is believed to be accurate in all respects. However, AV Costar™ cannot assume responsibility for any consequences resulting from the use thereof.

The information contained herein is subject to change without notice. Revisions or new editions to this publication may be issued to incorporate such changes.

+1.818.937.0700 | [www.avcostar.com](http://www.avcostar.com) [avsales@arecontvision.com](mailto:avsales@arecontvision.com)