

---

# Operation Manual

High Resolution  
Digital BOX Camera



**WDAC-5700C [ HIGH]**

---

Please read carefully before using and keep in a safe place.  
Design and specifications are subject to change without notice.

V.111



**CAUTION**  
RISK OF ELECTRIC SHOCK  
DO NOT OPEN



TO REDUCE THE RISK OF ELECTRIC SHOCK, DO NOT REMOVE COVER (OR BACK),  
NO USER SERVICEABLE PARTS INSIDE.  
REFER SERVICING TO QUALIFIED SERVICE PERSONNEL.



The lightning flash with an arrowhead symbol, within an equilateral triangle is intended to alert the user to the presence of uninsulated dangerous voltage within the product's enclosure that may be of sufficient magnitude to constitute a risk of electric shock to persons.



The exclamation point within an equilateral triangle is intended to alert the user to the presence of important operating and maintenance (servicing) instructions in the literature accompanying the appliance.

#### **Regulatory Notice**

This device complies with Part 15 of the FCC Rules. Operation is subject to the following two conditions :

- (1) This device may not cause harmful interference, and
- (2) this device must accept any interference received, including interference that may cause undesired operation.

This equipment has been tested and found to comply with the limits for a Class A digital device, pursuant to Part 15 of the FCC Rules. These limits are designed to provide reasonable protection against harmful interference in a residential installation.

This equipment generates, uses, and can radiate radio frequency energy and, if not installed and use in accordance with the instructions, may cause harmful interference to radio communications.

Operation of this equipment in a residential area is likely to cause interference, in which case the user will be required to correct the interference at his own expense.

**WARNING-** Changes or modifications not expressly approved by the manufacturer could void the users authority to operate the equipment.

**CAUTION-** To prevent electric shock and risk of fire hazards:

- Do NOT use power sources other than that specified.
- Do NOT expose this appliance to rain or moisture.

## **1.0 Features**

- 1/3"Sony Super HAD CCD II : 410K(NTSC)/470K(PAL) pixels
- High Resolution 600 TV Lines
- Day & Night (ICR)
- Digital Wide Dynamic Range
- Digital Noise Reduction
- Privacy mask Function
- On Screen Display
- Motion detection
- Parking Line
- High Light Compensation
- IR Smart

## 2.0 Warnings

- **The camera needs periodic inspection.**

Contact an authorized technician for inspection.

- **Stop using your camera when you find a malfunction.**

If you use your camera around smoke or unusual heat for a long time, fire may be caused.

- **Do not install the camera on a surface that can not support it.**

Unless the surface is suitable, it could cause falling or other hazards.

- **Do not hold plug with wet hands.**

It could cause an electric shock.

- **Do not disassemble the camera.**

It may result in fire, electric shock or other hazards.

- **Do not use the camera close to a gas or oil leak.**

It may result in fire or other hazards.

## 3.0 Precautions

**Do not install the camera in extreme temperature conditions.**



Only use the camera under conditions where temperatures are between -10 Deg. C and +50 Deg. C. (14 Deg. F and 122 Deg. F) Be especially careful to provide ventilation when operating under high temperatures.

**Do not install or use the camera in an environment where the humidity is high.**



It can cause the image quality to be poor.

**Do not install the camera under unstable lighting conditions.**



Severe lighting change or flicker can cause the camera to work improperly.

**Do not touch the front lens of the camera.**



It is one of the most important parts of the camera. Be careful not to be stained by fingerprint.

**Note**

- If the camera is exposed to spotlight or object reflecting strong light, smear or blooming may occur.
- Please check that the power satisfies the normal specification before connecting the camera.

**Do not drop the camera or subject them to physical shocks.**



It can cause malfunctions to occur.

**Never keep the camera face to strong light directly.**



It can damage the CCD.

**Do not expose the camera to rain or spill beverage on it.**



If it gets wet, wipe it dry immediately. Liquids can contain minerals that corrode the electronic components.

**Do not expose the camera to radioactivity.**



If it is exposed to radioactivity, For heated CCD, it will be out of order.

## Contents

1.0 Features .....	3	7.1 Main Menu .....	13
2.0 Warnings .....	4	7.2 Exposure .....	13
3.0 Precautions .....	5	7.3 White Balance .....	14
4.0 Components .....	7	7.4 Backlight .....	14
5.0 Names and Functions of Parts .....	8	7.5 Day & Night .....	15
5.1 Front .....	8	7.6 DPC .....	16
5.2 Side .....	9	7.7 Special .....	16
5.3 Bottom .....	9	8.0 Troubleshooting .....	19
5.4 Back .....	10	9.0 Specifications .....	21
6.0 Installation .....	11		
6.1 Lens .....	11		
6.2 Connecting to a Monitor .....	12		
6.3 Connecting to Power .....	12		
7.0 Setup Menu .....	13		

## 4.0 Components

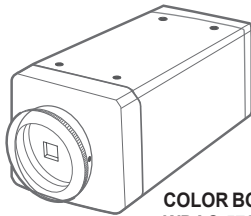

**COLOR BOX CAMERA  
WDAC-5700C**

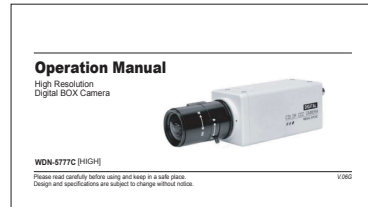

**Operation Manual**



**C-Mount adaptor**

## 5.0 Names and Functions of Parts

### 5.1 Front

- ❶ **Lens protection cap**  
Please cover the lens when not using it.
- ❷ **C-Mount lens adaptor**  
Please attach the C-Mount lens here.
- ❸ **CS-Mount lens adaptor**  
Please remove the C-MOUNT lens adaptor and then attach it.
- ❹ **Back Focus clamp screw**  
Please loosen the clamp screw with a screwdriver before adjusting the Back Focal length.

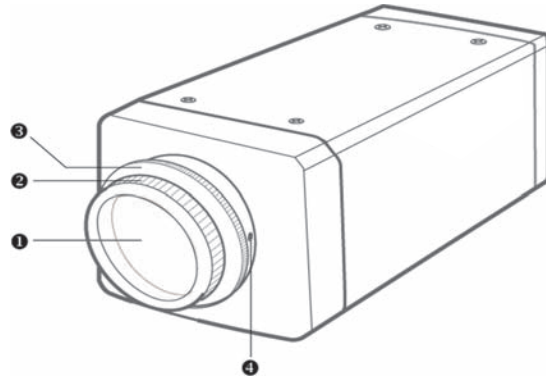

### 5.2 Bottom

- ❺ **Mounting bracket screw hole**  
Please use the screw hole when fixing the camera onto the mounting bracket.  
Please use the clamp screw as specified below.
  - The mounting bracket can be separated and attached to the top of the camera. In this instance please do not tighten the screw to a depth of more than 5mm, otherwise serious damage can occur to the inside of the camera.
- ❻ **MIC. Microphone**  
MIC. Input.

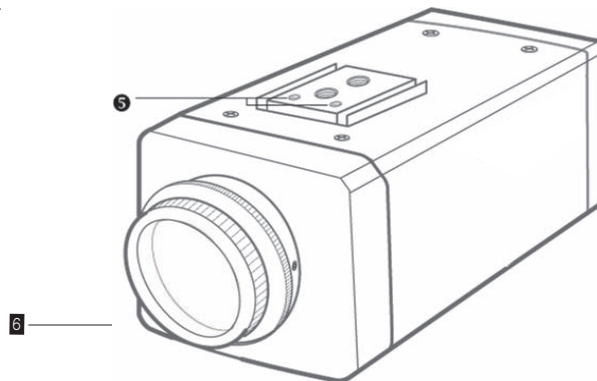

### 5.3 Back

#### 1 Video output terminal

Sends video signals and connects to the video input terminal of the monitor.

#### 2 Audio output terminal

Sends audio signals and connects to the audio input terminal of the monitor.

**3 SET button:** Used for the menu display. This button can be used to confirm settings after changing the value of the selected function or current conditions.

It is Jog Controller then you move Left&Right / Up & Down.

**UP & DOWN buttons:** Used for selecting items by moving the cursor up or down on the menu screen.

**LEFT & RIGHT buttons:** Used when changing item values, by moving the cursor to the left or right on the menu screen.

#### 4 Power lamp

Lights up when the correct power is supplied to the camera.

#### 5 Lens Connector

Connects C/ CS Lens mount

#### 6 Power input terminal

Connects to the power appropriate to each model.

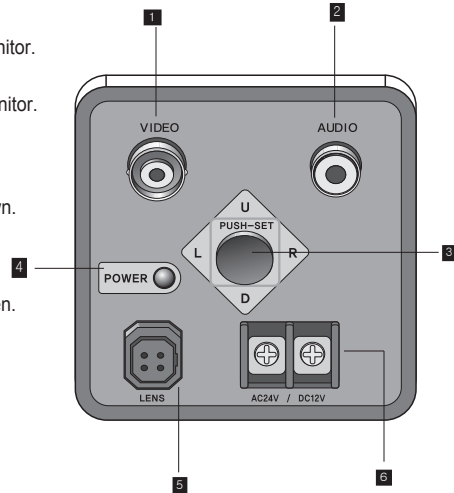

## 6.0 Installation

### 6.1 Lens

Lenses are sold separately. Lenses such as CS-Mount lens and C-Mount lens can be used.

#### • When using a C-Mount lens

Please take off the lens protection cap and attach the C-Mount lens to the camera by screwing it in clockwise.

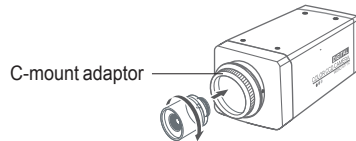

#### • When using a CS-Mount lens

- 1 Please take off the lens protection cap and C-mount adaptor.
- 2 Please attach the CS-Mount lens to the camera by screwing it in clockwise.

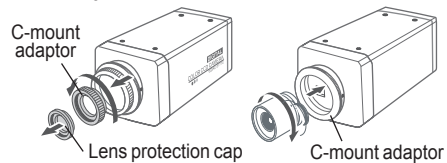

### 6.2 Connecting to a Monitor

Please connect the video output terminal located on the back of the camera to the monitor.

### 6.3 Connecting to Power

Each model has a different power input specification.

Please check the model type and standard power requirement before connecting to power.

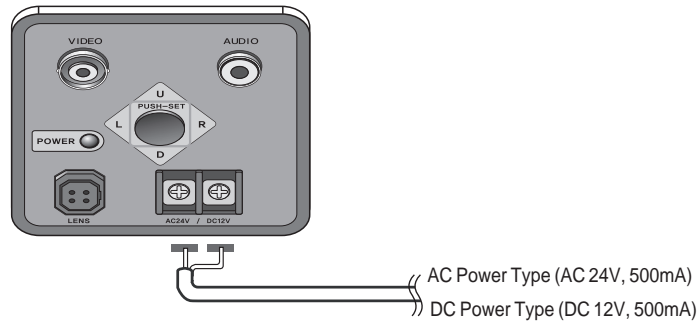

## 7.0 Setup Menu

### 7.1 MAIN MENU

SETUP	
LENS	DC
EXPOSURE	↓
WHITE BAL	ATW1
BACKLIGHT	OFF
DAY&NIGHT	AUTO ↓
DPC	↓
SPECIAL	↓
RESET	↓
EXIT	

The menu consists of the "Main Menu" and "Sub Menu". The main menu is 8 kinds of camera functions can be selected. To the right of each main menu selection, the sub-menu is displayed.

#### LENS

- LENS : Select lens type
  - ▷ DC / VIDEO / MANUAL

### 7.2 EXPOSURE

SETUP	
LENS	DC
EXPOSURE	↓
WHITE BAL	ATW1
BACKLIGHT	OFF
DAY&NIGHT	AUTO ↓
DPC	↓
SPECIAL	↓
RESET	↓
EXIT	



EXPOSURE	
SHUTTER	AUTO
BRIGHTNESS	50
AGC	----
DWDR	OFF
RETURN	RET ↓

- SHUTTER : You can set to auto or manual mode.
  - ▷ AUTO, 1/60(50), FLK, 1/250, 1/500, 1/1000, 1/2000, 1/4000, 1/5000, 1/10000, 1/100000sec
- BRIGHTNESS : You can adjust brightness level.
  - ▷ 0(dark) ~ 255 (bright) steps
- AGC : You can select auto gain control level
  - ▷ OFF / LOW / MIDDLE / HIGH
- DWDR : You can select WDR (Wide Dynamic Range) level.
  - ▷ DWDR : OFF / ON
    - ▶ LEVEL : 0-35 steps

### 7.3 WHITE BALANCE

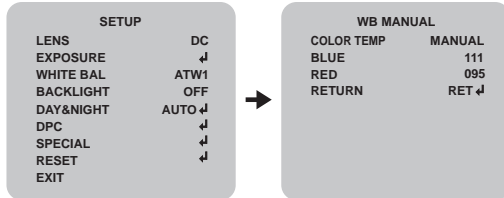

- WHITE BAL : You can select white balance mode.
  - ▷ ATW1 / ATW2 / AWC → SET / MANUAL (INDOOR / OUTDOOR / MANUAL)
    - ▶ ATM1 : Automatically adjusts color according to the available lighting. (2500°K → 9500°K)
    - ▶ ATW2 : Automatically adjusts color according to the available lighting. (2300°K → 10000°K)
    - ▶ AWC→SET : It is a fixed white balance mode that may be automatically readjusted only by pressing SET Button in ONE PUSH mode.
    - ▶ OUTDOOR : Set color temperature to be Outdoor light (5400°K)
    - ▶ INDOOR : Set color temperature to be Indoor light (3200°K)
    - ▶ MANUAL : Color can be corrected when the user increases or decreases "Red Gain" or "Blue Gain"
      - ▶ RED GAIN : Adjust R gain value 0 ~ 255
      - ▶ BLUE GAIN : Adjust B gain value 0 ~ 255

### 7.4 BACKLIGHT

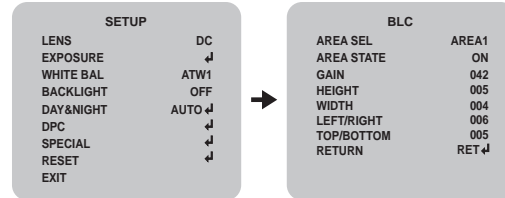

- BACKLIGHT : Select OFF / BLC / HLC
  - ▷ BLC (Back Light Compensation)
    - ▶ BLC : Select area, gain
    - ▶ AREA SEL : Select AREA1, AREA2
    - ▶ AREA STATE : Select OFF / ON
    - ▶ GAIN : Select 0 ~ 255 steps
    - ▶ HEIGHT : Select 0 ~ 15 steps
    - ▶ WIDTH : Select 0 ~ 15 steps
    - ▶ LEFT / RIGHT : Select 0 ~ 15 steps
    - ▶ TOP / BOTTOM : Select 0 ~ 15 steps

### 7.5 DAY & NIGHT

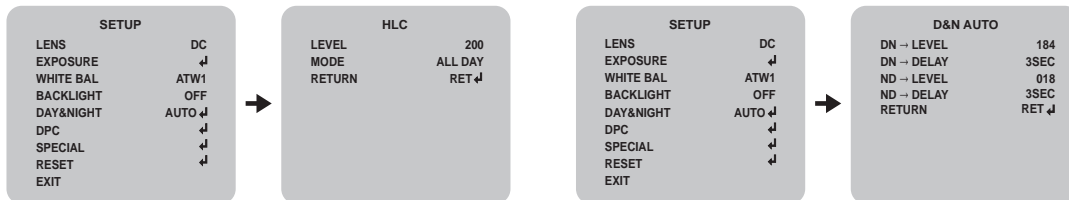

- ▷ HLC (High Light Compensation)
  - ▶ LEVEL : Select 0 ~ 255 steps
  - ▶ MODE : ALL DAY, NIGHT ONLY
- DAY & NIGHT : Select AUTO / COLOR / B/W / EXT
  - ▷ AUTO : Day & night Auto mode
    - ▶ D → N LEVEL : 128 ~ 192 steps
    - ▶ D → N DELAY : 1 ~ 30 SEC
    - ▶ N → D LEVEL : 0 ~ 64 steps
    - ▶ N → D DELAY : 1 ~ 30 SEC
  - ▷ COLOR : Day & Night only color mode
  - ▷ B/W : Day & night B/W mode
    - ▶ BURST : OFF / ON
    - ▶ IR SMART : OFF / ON
      - ▶ R GAIN : 0 ~ 255
      - ▶ HEIGHT : 0 ~ 15
      - ▶ WIDTH : 0 ~ 15
      - ▶ LEFT / RIGHT : 0 ~ 15
      - ▶ TOP / BOTTOM : 0 ~ 15
    - ▶ IR LEVEL : HIGH / LOW
  - ▷ EXT : Day & Night EXT mode



### 7.6 DPC (Dead Pixel Compensation)

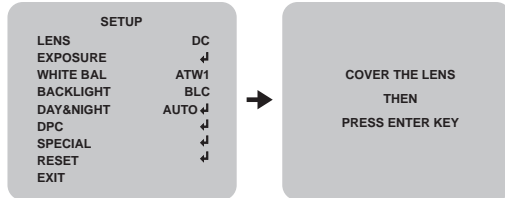

- DPC : Select dead pixel compensation processing

### 7.7 SPECIAL

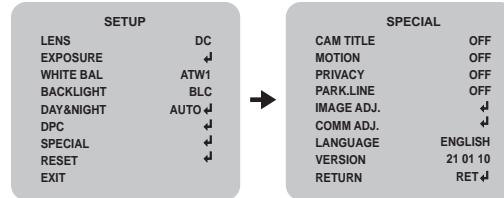

- CAM TITLE : Select camera title menu (Text edit).
- MOTION : Select camera title menu (Text edit)
  - ▶ AREA SEL : Select AREA1, AREA2, AREA3, AREA4
  - ▶ AREA STATE : Select OFF / ON
  - ▶ HEIGHT : Select 0 ~ 15 steps
  - ▶ WIDTH : Select 0 ~ 15 steps
  - ▶ LEFT / RIGHT : Select 0 ~ 15 steps
  - ▶ TOP / BOTTOM : Select 0 ~ 15 steps
  - ▶ DEGREE : Select 0 ~ 255 steps
  - ▶ VIEW : OFF / ON

### 7.7 SPECIAL

- PRIVACY : You can select Hide an area on the screen.
  - ▷ AREA SEL : Select AREA1, AREA2, AREA3, AREA4, AREA5, AREA6, AREA7, AREA8
  - ▷ AREA STATE : Select OFF / ON
  - ▷ HEIGHT : Select 0 ~ 124 steps
  - ▷ WIDTH : Select 0 ~ 200 steps
  - ▷ LEFT / RIGHT : Select 0 ~ 200 steps
  - ▷ TOP / BOTTOM : Select 0 ~ 124 steps
  - ▷ COLOR : Select 0 ~ 15 steps
- PARK. LINE : You can select parking line on the screen.
  - ▷ LT : You can adjust the top left area on screen.(0 ~ 255 steps)
  - ▷ LB : You can adjust the bottom left area on screen.(0 ~ 255 steps)
  - ▷ RT : You can adjust the top right area on screen.(0 ~ 255 steps)
  - ▷ RB : You can adjust the bottom right area on screen.(0 ~ 255 steps)
  - ▷ F : You can adjust the front area on screen.(0 ~ 255 steps)
  - ▷ N : You can adjust the near area on screen.(0 ~ 255 steps)
  - ▷ T : You can adjust the parking line thickness.(0 ~ 15 steps)

### 7.7 SPECIAL

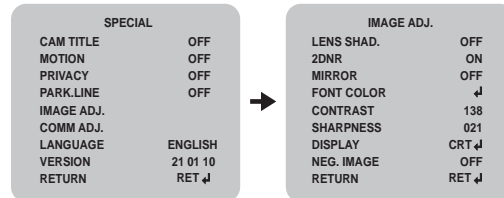

- IMAGE ADJ. : You can adjust camera image.
  - ▷ LENS SHAD : You can adjust lens shading on screen.
    - ▶ LEVEL : 0 ~ 255 steps
  - ▷ 2DNR : You can select Digital Noise Reduction on screen. (OFF/ON)
  - ▷ MIRROR : You can select mirror on screen. (OFF/ON)
  - ▷ FONT COLOR : You can select font color on screen.
    - ▶ FONT : 0 ~ 15 steps
    - ▶ ID & TITLE : 0 ~ 15 steps

### 7.7 SPECIAL

- ▷ CONTRAST : You can adjust contrast on screen. (0 ~ 255 steps)
- ▷ SHARPNESS : You can adjust sharpness on screen. (0 ~ 31 steps)
- ▷ DISPLAY : You can adjust display. (CRT / LCD / USER)
  - ▶ CRT (Cathode Ray Tube, Braun tube)
    - ▶ PED LEVEL : 0 ~ 63 steps
    - ▶ COLOR GAIN : 0 ~ 255 steps
  - ▶ LCD (Liquid Crystal Display)
    - ▶ GAMMA : 0.05 ~ 1.00 steps
    - ▶ PED LEVEL : 0 ~ 63 steps
    - ▶ COLOR GAIN : 0 ~ 255 steps
  - ▶ USER
    - ▶ GAMMA : 0.05 ~ 1.00 steps
    - ▶ PED LEVEL : 0 ~ 63 steps
    - ▶ COLOR GAIN : 0 ~ 255 steps
- ▷ NEG.IMAGE : You can select negative display. (OFF/ON)

### 7.7 SPECIAL

SPECIAL		COMM ADJ.	
CAM TITLE	OFF	CAM ID	001
MOTION	OFF	BAUD RATE	9600
PRIVACY	OFF	PROTOCOL	PELCO-D
PARK.LINET	OFF	DISPLAY ID	OFF
IMAGE ADJ.		ID POS	↓
COMM ADJ.		RETURN	RET ↓
LANGUAGE	ENGLISH		
VERSION	21 01 10		
RETURN	RET ↓		

- COMM ADJ. : You can adjust command.
  - ▷ CAM ID : Select the camera ID
    - ▶ 0 ~ 255
  - ▷ BAUD RATE : Select serial communication speed.
    - ▶ 2400 / 4800 / 9600 / 19200 / 38400 / 57600 bps
  - ▷ PROTOCOL : Select operating protocol
    - ▶ PELCO-D / PELCO-P
  - ▷ DISPLAY ID : Select display item.
    - ▶ OFF/ON
  - ▷ ID POS : You can adjust ID position on screen.
- LANGUAGE : You can select language
  - ▷ ENGLISH / CHINESE
- VERSION : Factory vision.
- RESET : Factory default reset.

## 8 TROUBLESHOOTING

If there are problems in operation, please refer to the items below.

If the problem persists, please contact the agent you purchased this product from.

Problems	Troubleshooting
<b>Nothing appears on the screen.</b>	<ul style="list-style-type: none"> <li>• Please check the power connection.</li> <li>• Please check the video signal line connection.</li> <li>• Please check and make sure that the lens mode is set to DC (VIDEO) when using a VIDEO (DC) lens.</li> </ul>
<b>The video image is not clear.</b>	<ul style="list-style-type: none"> <li>• Please clean the lens with a clean cloth or brush.</li> <li>• Please adjust that the screen is not exposed directly to a bright light.</li> <li>• Please move the camera if necessary.</li> <li>• Please readjust the back-focus of the camera.</li> </ul>
<b>The screen is dark.</b>	<ul style="list-style-type: none"> <li>• Please adjust the contrast feature of the monitor.</li> <li>• If you have an intermediate device, set the 75Ω /Hi-Z properly, and check the terminals.</li> <li>• Please check if an auto iris lens is being used and adjust the brightness level.</li> </ul>
<b>The MOTION DETECTION function is not working</b>	<ul style="list-style-type: none"> <li>• Please check if "MOTION DETECTION" mode is turned on.</li> <li>• Please check if the MD Sensitivity is too low.</li> <li>• Please check the setting of the MD AREA.</li> </ul>

Problems	Troubleshooting
The WDR function is not working	<ul style="list-style-type: none"> <li>• Please check if the WDR Level is too low.</li> <li>• Please check if the AE Mode is set to MANUAL. The WDR doesn't work in MANUAL Exposure mode.</li> </ul>
Colors are not quite right.	<ul style="list-style-type: none"> <li>• Please check if the camera is facing directly into sunlight or fluorescent light.</li> <li>• Please check if an auto iris lens is being used.</li> <li>• Please check the connection of the lens connector cable.</li> </ul>
The Day&Night function doesn't work	<ul style="list-style-type: none"> <li>• Please check if the AGC of EXPOSURE menu is set to OFF.</li> <li>• The Auto Day&amp;Night Function doesn't work in AGC OFF.</li> </ul>

## 9 Specification

Model	NTSC	PAL
Image Sensor	1/3" SONY Super HAD CCD II	
Total Pixels	811(H) × 508(V)	795(H) × 596(V)
Scanning system	2:1 Interlace	
Scanning Frequency	15.734KHz(H),59.94Hz(V)	15.625KHz(H),50Hz(V)
Sync. System	Internal	
Resolution	Max 600 TV lines in color (650TV lines in B/W)	
Min. illumination	Color : 0.1 lux , BW : 0.05 lux (0 lux @ IR LED on)	
Video Output	1.0 Vp-p (75 ohm, composite)	
S/N Ratio	more than 50dB (AGC off)	
Exposure	Shutter/Brightness/AGC/DWDR	
Lens	DC / VIDEO / MANUAL	
Gain Control	Off / Low / Middle / High	
Shutter Speed	1/60 ~ 1/100,000 sec	1/50 ~ 1/100,000 sec
DWDR	Off / On (0 ~ 35 steps)	
Flickerless	Off / On	
Brightness	0 ~ 255steps	
White Balance	ATW1 / ATW2 / AWC / Outdoor / Indoor / Manual	
BLC	Off / BLC / HLC	
BLC	Area / Gain selectable	
HLC	All Day / Night / (0~255 steps)	
Day&Night	Auto / Color / BW / Ext	
Auto	Level / Delay selectable	
BW	Burst off/on / IR Smart off/on (Gain/level selectable)	
DPC	Dead Pixels Compensation	
Special	Title / MD / PM / Parking / Image / Comm / Language / Version	

## 9 Specification

Model	NTSC	PAL
Cam Title	Text Edit	
Motion	Off / On (4 position)	
Privacy	Off / On (8 position)	
Park. Line	Off / On (variable size)	
Comm ADJ.	Cam ID / Baud Rate 2400, 4800, 9600, 19200, 38400, 57600	
Language	Protocol (Pelco-P/D) / ID Display (Position )	
Image ADJ	English / China	
Lens Shading	Lens Shad / DNR / Mirror / Font color / Contrast /	
DNR	Sharpness / Display / Neg. Image	
Mirror	Off / On (0-255 steps)	
Font Color	Off / On	
Contrast	ID & Title / OSD Font color selectable	
Sharpness	0-255 steps	
Display	0-31 steps	
Negative Image	CRT / LCD / User	
Power Source	Off / On	
Power Input	AC24V / DC12V	
Operating Temperature	Connector	
Operating Humidity	-10℃ ~ +50℃	
Storage Temperature	0 ~ 86% (non-condensing)	
	-20℃ ~ +60℃	