

L-Series Trim Rings

For use with the following models: TR-2, TR-2W, TRC-2, TRC-2W

3825 Ohio Avenue, St. Charles, Illinois 60174
800/736-7672, FAX: 630/377-6495
www.systemsensor.com

SPECIFICATIONS

Trim rings are available in 4 variations:

- TR-2: Wall mount, red
- TR-2W: Wall mount, white
- TRC-2: Ceiling mount, red
- TRC-2W: Ceiling mount, white

Backboxes supported:

- Single gang
- Double Gang
- 4" octagon
- 4" x 4" x 1 1/2" Back Box
- 4" x 4" x 2 1/8" Back Box

GENERAL DESCRIPTION

L-Series trim rings provide additional space within the backbox. The design is universal across the L-series notification appliance line and supports indoor horns, horn strobes, chimes, chime strobes, strobes, speakers, and speaker strobes.

INSTALLATION

Follow the instructions below for installing trim ring models TR-2, TR-2W, TRC-2, and TRC-2W with the L-Series devices: horn, horn strobe, strobe, chime, chime strobe, speaker, and speaker strobe.

1. Align two screw holes on the L-series mounting plate to the corresponding screw holes on the trim ring. (See Figures below.)
2. Align the two screw holes on the back box with the screw holes on the mounting plate.

FIGURE 1: WALL MOUNT TRIM RING

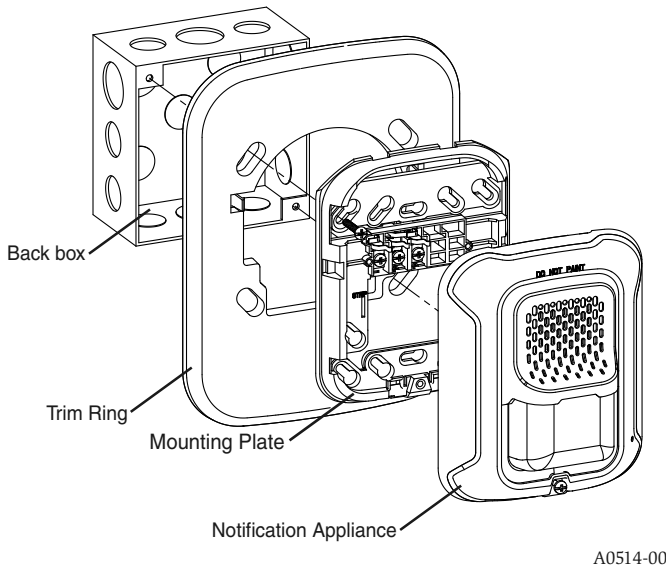

FIGURE 2: CEILING MOUNT TRIM RING

