

# RTS151

## Remote Test Station

**SPECIFICATIONS**

Dimensions:	4.8" H × 2.90" W × 1.4" D
Weight:	.16 lbs.
<b>Power Requirements</b>	
Alarm LED:	2.8 – 32 VDC, 10 mA max.
Coil Current:	95 mA max.
Test Switch:	10 VA @ 32 VDC
Reset Switch:	10 VA @ 32 VDC
Alarm Response Time:	40 sec. max.
Temperature:	-10°C to 60°C (14°F to 140°F)
Humidity:	95% RH Non-condensing Max
Listing:	UL, FM, CE

NOTE: RTS151 replaces RTS451.

NOTICE: This manual shall be left with the owner/user of this equipment.

NOTE: A test coil is required only for use with D2/DNR/DH400/DH500 models. For D2 models order part #DCoil. For the DH400/500 models order part is #Coil.

**GENERAL INFORMATION**

System Sensor's RTS151 is an automatic fire detector accessory designed to test a remotely located detector. Consult detector installation instructions for additional information.

The National Fire Protection Association has published codes, standards, and recommended practices for the installation and use of the above product. It is recommended that the installer be familiar with these requirements, with local codes, and any special requirements of the local authority having jurisdiction.

**RTS151 CONTENTS**

- 1 RTS151 remote test station
- 1 screw pack (2 mounting screws)
- 1 M02-04 test magnet

**WIRING OF RTS151**

Consult the appropriate detector installation instructions for the applicable wiring diagram. The RTS151 mounts to a single gang box (2 1/2" minimum depth), or directly to the wall or ceiling.

See Figure 8 for wiring diagram of RTS151 with Duct Smoke Detectors.

In Canadian applications, the RTS151 is intended to be located in the same room as the smoke detector and within 60 feet of the unit.

**OPERATION**

**Test Function**

Place and hold the painted side of the magnet to the test location RTS151.

**Alarm Indication**

With the magnet in place some time will elapse (40 sec. maximum) depending on the detector type, before the alarm indicating LED will light.

**Reset Function**

Gently insert a 1/8" maximum diameter tool into the hole until it stops and LED turns off. The RTS151 is capable of resetting only certain System Sensor models of detectors. Refer to detector installation instructions for additional information.

**FIGURE 1. RTS151 REMOTE TEST STATION:**

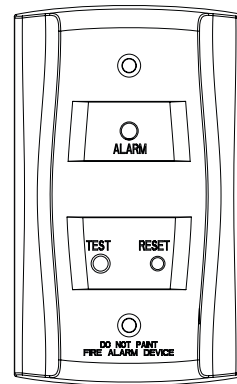

H0196-01

**FIGURE 2. WIRING DIAGRAM FOR RTS151 TO D4120 4-WIRE DUCT SMOKE DETECTOR:**

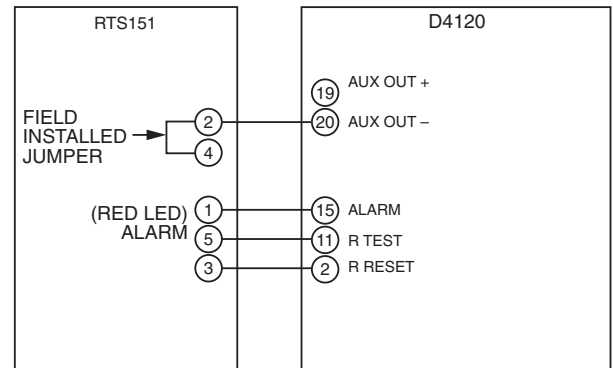

H0582-20

**FIGURE 3. WIRING DIAGRAM FOR RTS151 TO DNR 2-WIRE DUCT SMOKE DETECTOR WITH REMOTE TEST CAPABLE HEAD:**

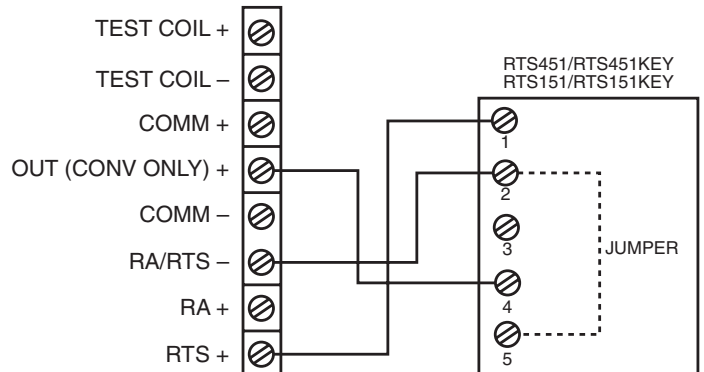

H0633-00

**FIGURE 4. WIRING DIAGRAM FOR RTS151 TO D2-2WIRE DUCT SMOKE DETECTOR:**

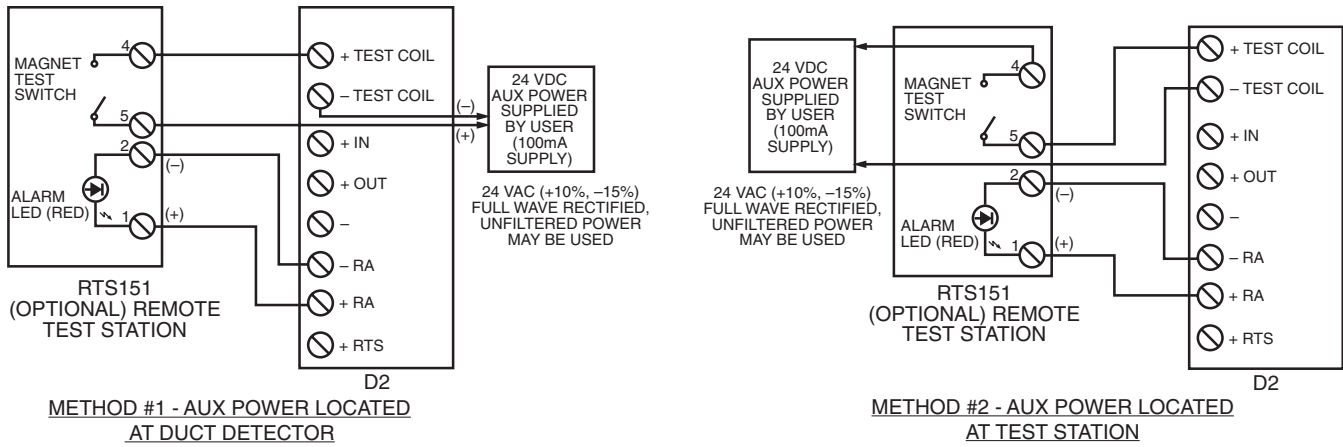

**NOTE:** THE USE OF THE RTS151 REQUIRES THE INSTALLATION OF AN ACCESSORY COIL, DCOIL, SOLD SEPARATELY.

H0612-11

**FIGURE 5. WIRING DIAGRAM FOR RTS151 TO DH100ACDC 4-WIRE DUCT SMOKE DETECTOR:**

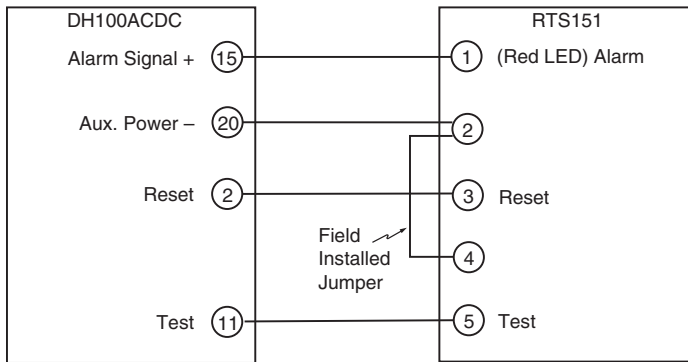

H0197-01

**FIGURE 6. WIRING DIAGRAM FOR RTS151 TO DH100 2-WIRE DUCT SMOKE DETECTOR:**

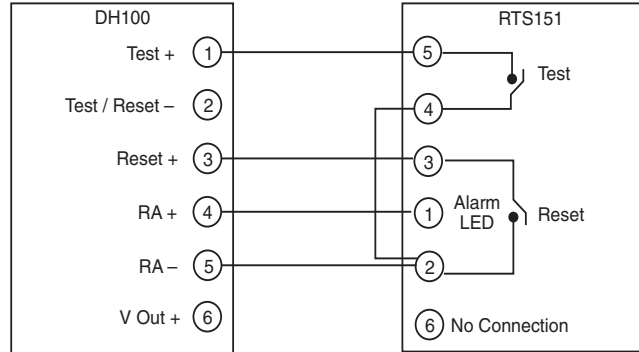

H0198-04

**FIGURE 7. WIRING DIAGRAM FOR RTS151 TO DH400ACDC DUCT SMOKE DETECTOR:**

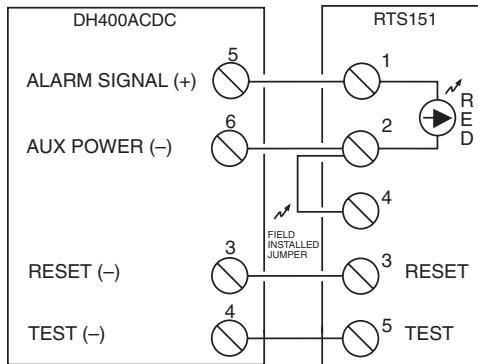

H0149-02

**FIGURE 8. WIRING DIAGRAM FOR RTS151 TO BEAM1224/BEAM1224S SMOKE DETECTOR:**

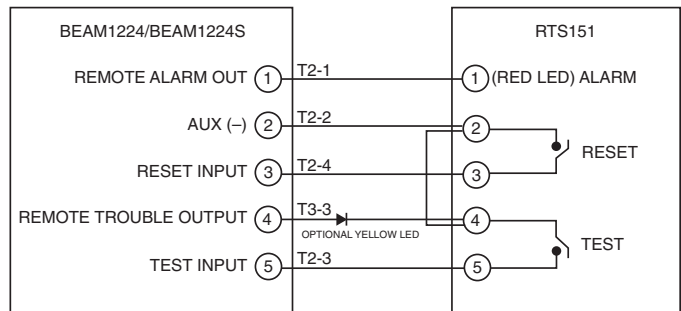

H0586-03

**THREE-YEAR LIMITED WARRANTY**

System Sensor warrants its enclosed product to be free from defects in materials and workmanship under normal use and service for a period of three years from date of manufacture. System Sensor makes no other express warranty for the enclosed product. No agent, representative, dealer, or employee of the Company has the authority to increase or alter the obligations or limitations of this Warranty. The Company's obligation of this Warranty shall be limited to the replacement of any part of the product which is found to be defective in materials or workmanship under normal use and service during the three year period commencing with the date of manufacture. After phoning System Sensor's toll free number 800-SENSOR2 (736-7672) for a Return Authorization number, send defective units postage prepaid to: Honeywell, 12220 Rojas Drive, Suite 700, El Paso

TX 79936, USA. Please include a note describing the malfunction and suspected cause of failure. The Company shall not be obligated to replace units which are found to be defective because of damage, unreasonable use, modifications, or alterations occurring after the date of manufacture. In no case shall the Company be liable for any consequential or incidental damages for breach of this or any other Warranty, expressed or implied whatsoever, even if the loss or damage is caused by the Company's negligence or fault. Some states do not allow the exclusion or limitation of incidental or consequential damages, so the above limitation or exclusion may not apply to you. This Warranty gives you specific legal rights, and you may also have other rights which vary from state to state.