

PRO4200

Two Reader Module (PRO42R2)

Installation Guide

Copyright© 2020 Honeywell. All rights reserved.

All product and brand names are the service marks, trademarks, registered trademarks, or registered service marks of their respective owners. Printed in the United States of America. Honeywell reserves the right to change any information in this document at any time without prior notice.

WIN-PAK® is a trademark of Honeywell International, Inc.

Ordering Information

Please contact your local Honeywell representative or visit us on the web at www.honeywellaccess.com for information about ordering.

Feedback

Honeywell appreciates your comments about this manual. Please visit us on the web at www.honeywellaccess.com to post your comments.

Discover | Customer Portal

Self-Service Product Support and Learning Management System

<https://honeywelldiscovertraining.com/login/discover/default.asp>

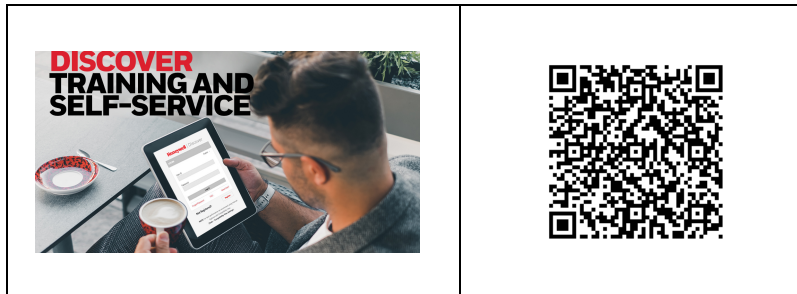

YouTube | Honeywell Help and Support

https://www.youtube.com/channel/UCBEL6ouNV_LN5IEpYRujMTg/featured

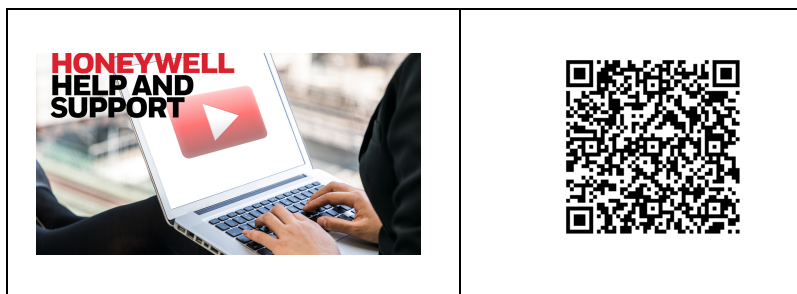

CONTENTS

Notices

Warnings and Cautions.....	v
Disclaimer.....	vi
Compliance.....	vii
CE and WEEE Marking	vii
Unpacking Procedure.....	vii
Shipping Instructions	ix
Limited Warranty	ix
Confidentiality	x

Installing the PRO4200 Two Reader Module

Description	11
Specification.....	12
Set Up.....	13
LED Operation.....	15
Power.....	16
Communications.....	16
Wiring	17
Wiring Diagram for Connectors TB1,TB7-9	18

2-Reader Input Module Programming Guide

.....	25
-------	----

(This page is left blank intentionally for double-sided printing.)

Notices

Warnings and Cautions



Warning

Before connecting the device to the power supply, verify that the output voltage is within specifications of the power supply.

Do not apply power to the system until **after** the installation has been completed. Personal injury or death could occur, and the equipment could be damaged beyond repair, if this precaution is not observed!



Warning: Fire Safety and Liability Notice

Never connect card readers to any critical entry, exit door, barrier, elevator, or gate without providing **an alternative exit** in accordance with all fire and life safety codes pertinent to the installation. These fire and safety codes vary from city to city and you must get approval from local fire officials whenever using an electronic product to control a door or other barrier. Use of egress buttons, for example, may be illegal in some cities. In most applications, single action exit without prior knowledge of what to do is a life safety requirement. Always make certain that any required approvals are obtained in writing. **DO NOT ACCEPT VERBAL APPROVALS, BECAUSE THEY ARE NOT VALID.**

Honeywell never recommends using the PRO4200 or related products for use as a primary warning or monitoring system. Primary warning or monitoring systems should always meet local fire and safety code requirements. The installer must also test the system on a regular basis by instructing the end user in appropriate daily testing procedures. Failure to test a system regularly could make the installer liable for damages to the end user if a problem occurs.



Note: See the Remote Enclosure Installation manuals PRO22ENC1, PRO22ENC2, PRO22ENC3 or PRO22ENC5 for installation instructions.



Warning:

EARTH ground all enclosures for proper installation.



Warning:

Use suppressors on all door strikes. Use S-4 suppressors for installation. Honeywell recommends only DC strikes.



Warning: For UL Installations:

- Wiring methods shall be in accordance with the National Electrical Code (ANSI/NFPA70).
- All interconnecting devices must be UL Listed.
- Not Evaluated by UL for fire, life safety, or burglary applications.
- Do Not Connect To A Receptacle Controlled By A Switch.

- All interconnecting wire must be UL/ULC Listed, rated and suitable for the use.



Caution:

IF ANY DAMAGE TO THE SHIPMENT IS NOTICED, A CLAIM MUST BE FILED WITH THE COMMERCIAL CARRIER RESPONSIBLE.



Caution: Electrostatic discharge can damage CMOS integrated circuits and modules. To prevent damage, always follow these procedures:

- Use static shield packaging and containers to transport all electronic components, including completed reader assemblies.
- Handle all ESD sensitive components at an approved static-controlled workstation. These workstations consist of a desk mat, a floor mat, and an ESD wrist strap. Workstations are available from various vendors.



Note: This equipment has been tested and found to comply with the limits for a Class A digital device, pursuant to part 15 of the FCC Rules. These limits are designed to provide reasonable protection against harmful interference when the equipment is operated in a commercial environment. This equipment generates, uses, and can radiate radio frequency energy and, if not installed and used in accordance with the instruction manual, may cause harmful interference to radio communications. Operation of this equipment in a residential area is likely to cause harmful interference, in which case the user will be required to correct the interference at his own expense.



Note: This document and the data in it shall not be duplicated, used, or disclosed to others for procurement or manufacture, except as authorized by and with the written permission of, Honeywell, Inc. The information contained in this document or in the product itself is considered the exclusive property and trade secrets of Honeywell, Inc. Copyright laws of the United States protect all information in this document or in the software product itself.



Note: Any use of this product is subject to the terms and acceptance of the Honeywell, Inc. Software Agreement. Please request a copy from Honeywell, Inc., and review the agreement carefully.

Disclaimer

Product Liability; Mutual Indemnification

In the event that a Customer receives a claim that a Product or any component thereof has caused personal injury or damage to property of others, Customer shall immediately notify Honeywell in writing of all such claims. Honeywell shall defend or settle such claims and shall indemnify and hold Customer harmless for any costs or damages including reasonable attorneys' fees which Customer may be required to pay as a result of the defective Product or the negligence of Honeywell, its agents, or its employees.

Customer shall hold harmless and indemnify Honeywell from and against all claims, demands, losses, and liability arising out of damage to property or injury to persons

occasioned by or in connection with the acts or omissions of Customer and its agents and employees, and from and against all claims, demands, losses, and liability for costs of fees, including reasonable attorneys' fees, in connection therewith.

Compliance

To obtain applicable EU compliance Declaration of Conformities for this product, please refer to our website, <https://www.security.honeywell.com/All-Categories/access-control-systems/control-panels-hardware>. For any additional information regarding the compliance of this product to any EU-specific requirements, please contact:

Honeywell Security & Communications
Honeywell Security - Quality Assurance Dept., Newhouse Industrial Estate
Motherwell
Lanarkshire ML1 5SB
Scotland
United Kingdom
Tel: +44(0) 1698 738200
Email: UK64Sales@Honeywell.com

CE and WEEE Marking

Description of the used symbol.

 CE -Standard -Logo. This product complies with the harmonized Regulation of the EU



WEEE symbol. It indicates this product is to be recycling and not been thrown in the dustbin

Unpacking Procedure



Caution:

If any damage to the shipment is noticed before unpacking, a claim must be filed with the commercial carrier.

All containers should be opened and unpacked carefully in order to prevent damage to the contents.

The following steps are used to unpack equipment in preparation for installation:

1. Open the container and remove the unit(s) and all packing material. Retain the container and all packing materials. They may be used again for reshipment of the equipment, if needed.
2. Inspect the contents for shortage. If items are missing items, contact the order entry department at 800-323-4576.
3. Visually check contents. If damage is discovered, perform the following:

Notices
Unpacking Procedure

- If shipping caused damage to the unit, a claim must be filed with the commercial carrier.
- If any other defect is apparent, call for a return authorization.

Shipping Instructions

To ship equipment back to Honeywell, Inc.:

1. Contact the customer service department at 800-323-4576 before returning equipment. When you call please have available:
 - A description of the problem or reason you are returning the equipment.
 - Your original purchase order number, invoice number and if the unit is still under warranty.
 - A new purchase order number if the unit is not under warranty.
2. From the customer service department, obtain the Return Authorization Number (RMA).
3. Show the RMA number on all packages shipped. Packages which are not marked with an RMA number will be refused at the factory and returned to you **COD**.
4. Carefully pack the equipment for shipment. Use the original packing material whenever possible.

Limited Warranty

All Products sold or licensed by Honeywell include a warranty registration card which must be completed and returned to Honeywell by or on behalf of the end user in order for Honeywell to provide warranty service, repair, credit or exchange. All warranty work shall be handled through Customer which shall notify Honeywell and apply for a Return Merchandise Authorization (RMA) number prior to returning any Product for service, repair, credit, or exchange. Honeywell warrants that its Products shall be free from defects in materials and workmanship for a period of two years from date of shipment of the Product to Customer. The warranty on Terminals, Printers, Communications Products and Upgrade kits is 90 days from date of shipment. Satisfaction of this warranty shall be limited to repair or replacement of Products which are defective or defective under normal use. Honeywell's warranty shall not extend to any Product which, upon examination, is determined to be defective as a result of misuse, improper storage, incorrect installation, operation or maintenance, alteration, modification, accident or unusual deterioration of the Product due to physical environments in excess of the limits set forth in Product manuals. THERE ARE NO WARRANTIES WHICH EXTEND BEYOND THIS PROVISION. THIS WARRANTY IS IN LIEU OF ALL OTHER WARRANTIES WHETHER EXPRESS, IMPLIED OR STATUTORY, INCLUDING IMPLIED WARRANTIES OF MERCHANTABILITY OR FITNESS FOR ANY PARTICULAR PURPOSE. NO REPRESENTATION OR WARRANTY OF THE DISTRIBUTOR SHALL EXTEND THE LIABILITY OR RESPONSIBILITY OF THE MANUFACTURER BEYOND THE TERMS OF THIS PROVISION. IN NO EVENT SHALL HONEYWELL BE LIABLE FOR ANY RE-PROCUREMENT COSTS, LOSS OF PROFITS, LOSS OF USE, INCIDENTAL, CONSEQUENTIAL OR SPECIAL DAMAGES TO ANY PERSON RESULTING FROM THE USE OF HONEYWELL'S PRODUCTS.

Confidentiality

All software, drawings, diagrams, specifications, catalogs, literature, manuals and other materials furnished by Honeywell relating to the design, use and service of the Products shall remain confidential and shall constitute proprietary rights of Honeywell and Customer agrees to treat such information as confidential. Customer shall acquire no rights in the design of the Products or the related materials except to use such information solely for the purpose of and only during the time it sells the Products. Customer shall not copy the design of any of the Products or use or cause to be used any Product design or related materials for its own benefit or for the benefit of any other party. The covenants contained in this section shall remain effective throughout the term of this Agreement and thereafter unless specifically waived by Honeywell in writing.

Installing the PRO4200 Two Reader Module

Description

The PRO4200 Two-Reader Module provides support for up to two access control doors by providing connections for Wiegand or Clock/Data type readers, supervised inputs, and relay outputs. You can either mount the board in a rack or open and flat. If you rack-mount the board, only one edge is accessible for wiring; however, a flat mount increases the amount of available I/O slightly but significantly decreases the number of boards that can be mounted in one enclosure.

The I/O terminals are organized to support two doors. Starting at the bottom of the rack-mount side of the board, the connector provides power to the board and connector provides communication with the Intelligent Controller (PRO42IC and PRO32IC). The next set of terminals connects reader 2. The next set of terminals connects the I/O typically associated with reader 2, namely the Door Status and REX status inputs and the Door Lock and Lock Status relay outputs. Continuing up this edge the next two connectors provide the reader and associated I/O terminals for reader 1. The last connector on the rack-mount edge provides terminals for two additional general-purpose inputs.

When the board is mounted flat, two additional relay outputs and two additional general-purpose inputs are available along with two dedicated inputs for cabinet tamper and power fault detection on the opposite edge of the board.

The reader interface accepts a Wiegand signal of Data 1 and Data 0 or a Clock and Data signal and provides 5VDC or 12VDC reader power, a tri-stated LED control and buzzer control. Two of the six form-C relay outputs are sized for the inductive load of door locks and the other four are designed to handle dry-circuit signals. All of the inputs are capable of four-state supervision except the two dedicated inputs.

Communication to the control panel is accomplished via an RS-485 interface. This board requires 12VDC input power. When communication to the control panel is lost, this board can grant access based on facility code only. General purpose outputs will retain the setting at the time communication was lost. Up to eight facility codes may be active in each PRO32IC and PRO42IC. Keypad input must follow the reader input format and is in place of or multiplexed with the reader data.

Specification

The Two-Reader Module is for use in low voltage, class 2 circuits only.

Primary power:

12VDC + 10%, 650mA maximum with 5V readers, 300 mA max. excluding readers

Relay contacts:

- Relays 0 through 1 outputs, Form-C, 5A @ 30VDC, resistive
- Relays 2,3,4, and 5 outputs, Form-C,2A @ 30VDC,resistive

Inputs:

- 8 supervised, End of Line resistors 1k ohm \pm 1% tolerance
- 2 unsupervised dedicated inputs

Communication:

RS-485 Range 9,600 to 38,400 bps

Wire requirements:

Power	1 twisted pair, 18AWG(Honeywell 3114 or equivalent)
RS-485	24 AWG, 4,000 feet (1,200 m) max., twisted pair with shield (120 Ω , 23pF) (Honeywell 3328 or equivalent)
Inputs	1 twisted pair per input, 30 ohms max.
Outputs	As required for the load
Readers	6 conductors, 18AWG, 500 feet (150m) max. shield and drain

Mechanical:

Dimension	5.5" (140 mm) W x 9" (229 mm) L x 1" (25 mm) H
Weight	12 oz. (340 g) nominal

Environment:

Temperature	0°C to +49°C, operating, -55°C to +85°C, storage
Humidity	0% to 85% RHNC

Set Up

Table 1: PRO4200 IN Module Jumper Setting

Jumper	Setting	Default	Selected
J1	OFF	*	Port 1 RS-485 EOL terminator is not active
	ON		Port 1 RS-485 EOL terminator is active
J2	Position 5		Reader 1 Power terminals provides 5 VDC
	Position 12		Reader 1 Power terminal provides 12 VDC
J3	Position 5		Reader 2 Power terminal provides 5 VDC
	Position 12	*	Reader 2 Power terminal provides 12 VDC

S8	S7	S6	S5	S4	S3	S2	S1	Selection
			OFF	OFF	OFF	OFF	ON	ADDRESS 1*
			OFF	OFF	OFF	ON	OFF	ADDRESS 2
			OFF	OFF	OFF	ON	ON	ADDRESS 3
			OFF	OFF	ON	OFF	OFF	ADDRESS 4
			OFF	OFF	ON	OFF	ON	ADDRESS 5
			OFF	OFF	ON	ON	OFF	ADDRESS 6
			OFF	OFF	ON	ON	ON	ADDRESS 7
			OFF	ON	OFF	OFF	OFF	ADDRESS 8
			OFF	ON	OFF	OFF	ON	ADDRESS 9
			OFF	ON	OFF	ON	OFF	ADDRESS 10
			OFF	ON	OFF	ON	ON	ADDRESS 11
			OFF	ON	ON	OFF	OFF	ADDRESS 12
			OFF	ON	ON	OFF	ON	ADDRESS 13
			OFF	ON	ON	ON	OFF	ADDRESS 14
			OFF	ON	ON	ON	ON	ADDRESS 15

Installing the PRO4200 Two Reader Module
Set Up

S8	S7	S6	S5	S4	S3	S2	S1	Selection
			ON	OFF	OFF	OFF	OFF	ADDRESS 16
			ON	OFF	OFF	OFF	ON	ADDRESS 17
			ON	OFF	OFF	ON	OFF	ADDRESS 18
			ON	OFF	OFF	ON	ON	ADDRESS 19
			ON	OFF	ON	OFF	OFF	ADDRESS 20
			ON	OFF	ON	OFF	ON	ADDRESS 21
			ON	OFF	ON	ON	OFF	ADDRESS 22
			ON	OFF	ON	ON	ON	ADDRESS 23
			ON	ON	OFF	OFF	OFF	ADDRESS 24
			ON	ON	OFF	OFF	ON	ADDRESS 25
			ON	ON	OFF	ON	OFF	ADDRESS 26
			ON	ON	OFF	ON	ON	ADDRESS 27
			ON	ON	ON	OFF	OFF	ADDRESS 28
			ON	ON	ON	OFF	ON	ADDRESS 29
			ON	ON	ON	ON	OFF	ADDRESS 30
			ON	ON	ON	ON	ON	ADDRESS 31
	OFF	OFF						Reserved
	OFF	ON						9,600 BPS
	ON	OFF						19,200 BPS
	ON	ON						38,400 BPS*
OFF								Not Used*

* = Default

LED Operation

The Two-Reader Module uses two onboard LEDs (D1 and D2) to provide status information during the power-up sequence as well as during normal operation. The Two-Reader Module also uses two onboard LEDs (D3 and D4) to indicate reader activity.

Table 2: LED Settings

Mode	LED D1	LED D2	Description
Power-up sequence	ON	OFF	Start power-up, hardware setup
	OFF	ON	Testing RAM
	ON	ON	Testing ROM and completing initialization
	FLASH	ON	LED D1 flashes 4 times after power-up is completed
Normal Operation	FLASH		This is the processor heartbeat LED. It flashes once every second. A short ON time (~20% duty cycle) indicates the board is offline or has lost serial communication with the Controller board. A long ON time (~80% duty cycle) indicates the board is online and communicating with the Controller board.
		FLASH	Flash when there is activity on its Serial Port.

In addition to the status LEDs, there are six additional relay status LEDs and eight input status LEDs on board. The input LEDs flash when there is a fault associated with the input. When any relay or input is energized or ON, its corresponding status LED becomes ON also. The LED remains ON for as long as the relay is energized.

The assignment for each relay status LED is shown in the following table:

The following table lists the LED D1 through D4.

Table 3: Additional PRO4200 Two Reader Module LEDs

LED number	Description
D3	Reader 1 activity
D4	Reader 2 activity
D5	Input 0

Table 3: Additional PRO4200 Two Reader Module LEDs

LED number	Description
D6	Input1
D7	Input 2
D8	Input 3
D9	Input 4
D10	Input 5
D11	Input 6
D12	Input 7
D13	Tampert
D14	Power
D15	Relay 0 status
D16	Relay 3 sttatus
D17	Relay 2 status
D18	Relay 4 status
D19	Relay 1 status
D20	Relay 5 status

Power

The Two-Reader Module accepts 12VDC with an operating range of 10 to 14VDC and consumes a maximum of 300mA of current without readers. Locate power source as close to this board as possible. Connect power with minimum of 18 AWG wire. The input voltage is regulated to 5VDC. The regulated voltage or the 12VDC (pass through) is available for powering the readers. The selection is made via jumpers and is available at both reader connectors.



Note: POLARITY for 12VDC power is important. Make sure the +12 VDC is connected to the terminal labeled +12V and the return is connected to the terminal labeled GND.

Communications

The Two-Reader Module communicates to the host controller via an RS-485 interface. The interface allows for multi-drop communication of up to 4,000 feet

(1,200 m) total per port. Use twisted pair (minimum 24 AWG) with shield for communication. The default speed of this port is 38.4Kbps but it can be downgraded to 19.2Kbps or 9.6Kbps if the line conditions or receiving equipment require it (see Table 1 on page 3 for jumper settings and Table 2 on page 4 for DIP switch settings).

For wiring to an RS-485 port:

1. TR+ is the plus side of the transmit and receive differential signal.
2. TR- is the negative side of the transmit and receive differential signal.
3. GND is the signal ground. The wiring for this signal is required and NOT optional. This signal must NOT be connected to chassis GND.

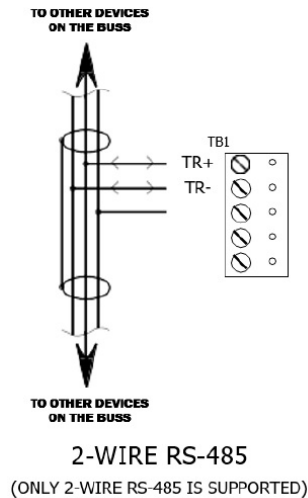

4. Use 24 AWG low capacitance, twisted-pair, shielded cable (Honeywell 3328 or equivalent).

Wiring

This section presents information on reader wiring, input wiring, and control output wiring.

The following figure shows the PRO4200 board and identifies its terminal block pin assignments.

Wiring Diagram for Connectors TB1, TB7-9

Figure 1: PRO4200 Two Reader Module: Connectors TB1, TB7-9.

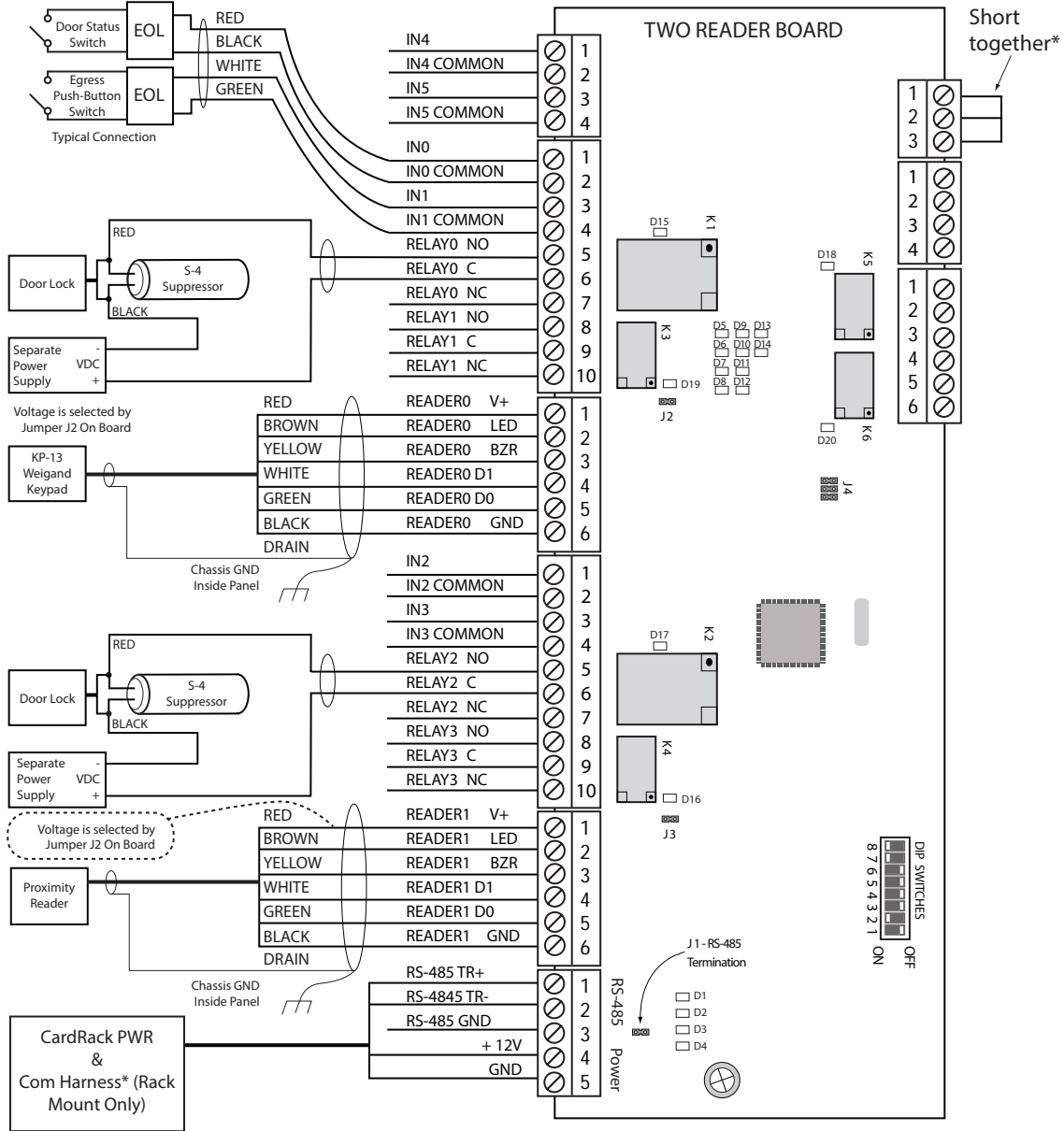

* Rack Mount Configuration



Note: See [LED Operation on page 16](#) for descriptions of LEDs D1-D20.

Note: Reader, Input, and Output addresses on the PRO4200 panel are labeled starting with address 0. This translates to address 1 in the WIN-PAK per the example below:

PRO4200 Device	PRO4200 Address	WIN-PAK Address
----------------	-----------------	-----------------

Reader\ Input\ Output	0	1
Reader\ Input\ Output	1	2

Note: The SIO board port for a PRO42IC in WIN-PAK is port 6 and is set as the default.

Each reader port supports a reader with TTL (D1/D0, Clock/Data), F/2F, or 2-wire RS-485 signaling. Power to the reader is selectable:

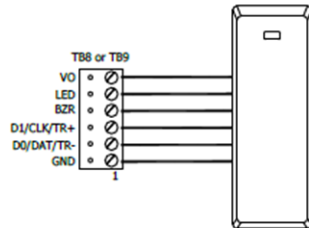

Typical D1/D0 – Clock/Data Reader

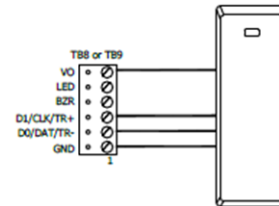

**Typical 2-Wire RS-485 Device
(OSDP Reader for Example)**

Input on supervised F/2F readers may be unsupervised or supervised (supervised shown).

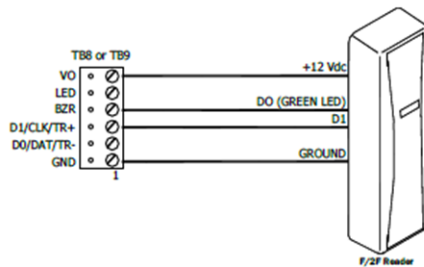

Typical Unsupervised F/2F Reader

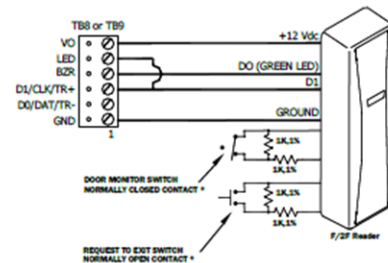

Typical Supervised F/2F Reader

Reader Wiring

The following Honeywell reader module numbers have been approved by UL for use with the PRO4200: OM40BHONA, OM55BHONA, OP10HONE, OP30HONE,

OP40HONA, OP90HONA, OT30HONA, OT31HONA, OT35HONA, and OT36HONA.

Each reader port supports a reader with TTL interface. Power to the reader is selectable as 5VDC or 12VDC (pass-through). This selection is done by setting the jumpers J2 for reader 1 and J3 for reader 2. Set jumper at position "5" for 5VDC or "12" for pass-through 12VDC. The factory defaults set J2 and J3 to "5".

For wiring to a reader port

Table 4: *Settings for Wiring to a Reader Port*

Terminal	Typical Wire Color	Wiegand Reader	Clock/Data Readers
1	Red	Power (5 or 12 Vdc)	Power (5 or 12 Vdc)
2	Brown	LED control	LED control
3	Yellow	Beeper Control	Beeper Control
4	White	Data 1 Signal	Clock Signal
5	Green	Data 0 Signal	Data 0 Signal
6	Black	Common	Common

The LED control terminal in each reader port can be configured via host software to support one-wire single or bi-colored reader LED. An example of the most common configuration is shown below. If Beeper Control is not used, its terminal can be programmed to be the second wire for the two-wire bi-colored reader LED.

Table 5:

LED Output->	High	Tri- Stated	Low
Single Color LED	LED ON	LED OFF	LED OFF
Bi- Color LED	Green LED ON	Both LEDs OFF	Red LED ON

To fully utilize each reader port, a 6-conductor cable (18AWG) is required. Reader port configuration is set via host software

Input Wiring

Inputs 0 to 7 may be configured to use normally open or normally closed contacts and non-supervised or supervised (with standard $\pm 1\%$ tolerance 1K ohm). Four of these

inputs have default functional definitions, but all eight can be configured to monitor general-purpose sensors.

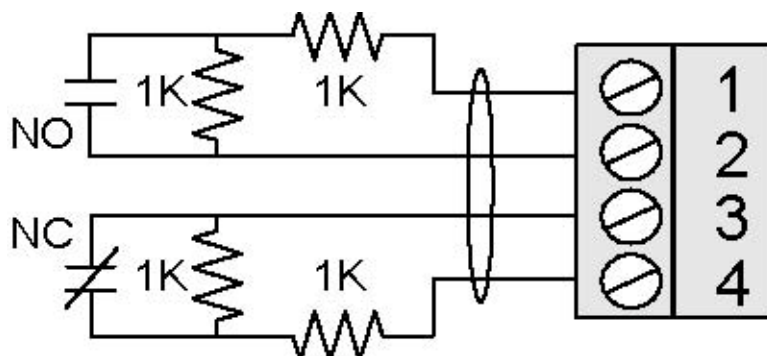

By default, Input 0 is defined as the Door Status Input corresponding to reader 1 and Input 1 is defined as the REX input corresponding to reader 1. Also by default, Input 2 is defined as the Door Status Input corresponding to reader 2 and Input 3 is defined as the REX input corresponding to reader 2. Inputs 4, 5, 6 and 7 are general purpose inputs that can be used to monitor sensors or as control inputs. Inputs 6 and 7 are not accessible when the board is rack mounted.

Inputs TMP and PFL are typically used for monitoring cabinet tamper and power failure respectively. These two inputs are not supervised and are not accessible when the board is rack-mounted. These inputs were primarily provided for the case when this board is mounted remotely and cannot take advantage of the tamper and power fail detect inputs on the controller board. If these inputs are not used, install a short piece of wire at the input to indicate safe condition.

Input configuration including debounce and hold time is set via host software.

Control Output Wiring

Six form-C relay contacts are provided for controlling door strike or other devices. Each may be assigned to door-related functions or general-purpose output. They are configurable as standard (energize to activate) or fail-safe (de-energize to activate) via host software.

The energized or ON time of each relay can be configured using Pulse control for single or repeating pulses via host software. The energized or ON time for a single pulse can be extended up to 24 hours. For repeating pulses, the on/off time can be defined in 0.1 second increments and be repeated up to 255 times.

Relays 0 and 2 are rated for and normally used to control the door locks associated with readers 0 and 1 respectively. While Relays 0 and 2 are sized to handle the typical loads generated by electrical locks, load switching can cause abnormal contact wear and premature contact failure. Switching of inductive loads (i.e., strike) also causes EMI (electromagnetic interference) which may interfere with normal operation of other equipment. To minimize premature contact failure and to increase system reliability, a contact protection circuit is highly recommended. The following two circuits are suggested. Locate the protection circuit as close to the load as possible

(within 12 inches [30cm]); the effectiveness of the circuit decreases as the distance from the load increases.



Note: Only relays 0 and 2 can be used for door hardware in a UL installation

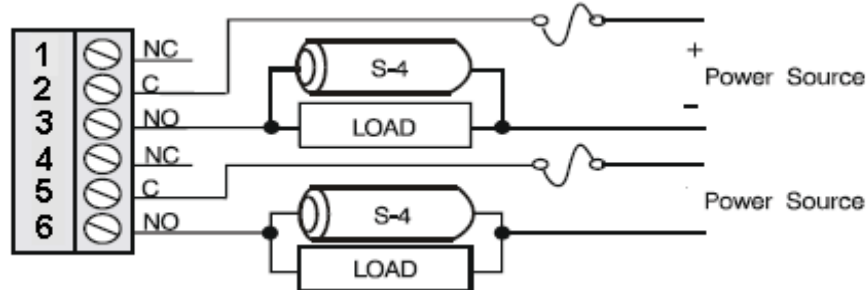

Relays 1 and 3 are dry-circuit level signal relays typically used to indicate the status of the door lock. Relays 4 and 5 are general-purpose relay outputs and are not available when the board is rack-mounted.

Use sufficiently large gauge of wires for the load current to avoid voltage loss.

Mounting Options

This board can be mounted on-edge in the rack-mount enclosure provided by Honeywell or it can be mounted flat against any surface using standoffs under the mounting holes provided in each of the four corners of this board.

When this board is rack-mounted, the connectors for two general-purpose inputs, two general-purpose outputs, and two dedicated inputs are not accessible and should not be used.

The most common reason for mounting a board flat is that it is being installed remotely to be located near the door(s) being monitored. In this case it will be mounted in its own enclosure creating the need to monitor cabinet tamper and power fault detection inputs. The two additional general-purpose inputs and outputs provided allow for the monitoring of extra sensors and control of local horns or other equipment.

Installing the Module

1. Set Jumpers and DIP switches.
2. Mount this board in the appropriate enclosure - If this board is being mounted in a rack, the component side of the board is to your right as you face the rack.
3. Connect the communications and power supply to the circuit boards with the Power Supply Harness.



Warning: DO NOT CONNECT THE POWER SUPPLY TO THE AC SOCKET UNTIL ALL WIRING HAS BEEN INSTALLED AND RECHECKED.

4. Connect wiring to the reader interfaces as appropriate.
5. Connect wiring to input sensors or install jumper wire as appropriate.

6. Connect relay output wiring as appropriate.
7. Connect communications wiring to the Intelligent Controller.
8. Recheck wiring for correct connections and continuity.
9. When all boards have been installed, connect the power supply cord for proper
10. connections and power.
11. Set up the panel controls using the host software.

(This page is left blank intentionally for double-sided printing.)

2-Reader Input Module Programming Guide

PRO42R2-Reader Input Module Programming Sheets:

Project Name	
Location / Country	
Host IC Board	0
Board Description	
PW Panel RS485 Port	3
Board Address	0
Location	
Floor	
Cabinet Location	
Tamper Input	Connected
Powerfail	Shunted
Termination Jumper J1	Not Active

RS485 Port +	Power Connector	Connected Cable #	Cable Destination	Conductor Color
RS485 TX (+)	Pin #1			
RS485 RX (-)	Pin #2			
Common	Pin #3			

Power	Power Connector	Connected Cable #	Cable Destination	Conductor Color
Power (+)	Pin #1			
Power (-)	Pin #2			

Inputs 4 and 5	Connected Cable #	Cable Destination	Conductor Color
Input 4	Pin #1		
Input 4 Com	Pin #2		
Input 5	Pin #3		
Input 5 Com	Pin #4		

Door 1 Input / Output	Connected Cable #	Cable Destination	Conductor Color
Input 0	Pin #1		
Input 0 Com	Pin #2		
Input 1	Pin #3		
Input 1 Com	Pin #4		
Relay 0 No	Pin #5		

2-Reader Input Module Programming Guide

Door 1 Input / Output		Connected Cable #	Cable Destination	Conductor Color
Relay 0 Com	Pin #6			
Relay 0 NC	Pin #7			
Relay 1 No	Pin #8			
Relay 1 Com	Pin #9			
Relay 1 NC	Pin #10			

Reader 1 WIN-PAK Reader 1 (the reader address used in the WIN-PAK hardware setup)				
VDC Select J2	5 Volt	Connected Cable #	Cable Destination	Conductor Color
DC Out (+)	Pin #1			
Red LED	Pin #2			
Beeper Ctrl	Pin #3			
Data - 1	Pin #4			
Data - 0	Pin #5			
Common	Pin #6			
Note: Reader 0 is Reader 1 in WIN-PAK				

Door 2 Input / Output		Connected Cable #	Cable Destination	Conductor Color
Input 2	Pin #1			
Input 2 Com	Pin #2			
Input 3	Pin #3			
Input 3 Com	Pin #4			
Relay 2 No	Pin #5			
Relay 2 Com	Pin #6			
Relay 2 NC	Pin #7			
Relay 3 No	Pin #8			
Relay 3 Com	Pin #9			
Relay 3 NC	Pin #10			

Reader 2 WIN-PAK Reader 2 (the reader address used in the WIN-PAK hardware setup)				
VDC Select J2	5 Volt	Connected Cable #	Cable Destination	Conductor Color
DC Out (+)	Pin #1			
Red LED	Pin #2			
Beeper Ctrl	Pin #3			
Data - 1	Pin #4			
Data - 0	Pin #5			
Common	Pin #6			
Note: Reader 1 is Reader 2 in WIN-PAK				

Inputs 6 and 7		Connected Cable #	Cable Destination	Conductor Color
Input 6	Pin #1			
Input 6 Com	Pin #2			
Input 7	Pin #3			
Input 7 Com	Pin #4			

Inputs 4 and 5		Connected Cable #	Cable Destination	Conductor Color
Relay 4 NC	Pin #1			
Relay 4 Com	Pin #2			
Relay 4 NO	Pin #3			
Relay 5 NC	Pin #4			
Relay 5 Com	Pin #5			
Relay 5 NO	Pin #6			

(This page is left blank intentionally for double-sided printing.)

For more information: www.honeywellaccess.com

Discover | Customer Portal

Self-Service Product Support and Learning Management System

<https://honeywelldiscovertraining.com/login/discover/default.asp>

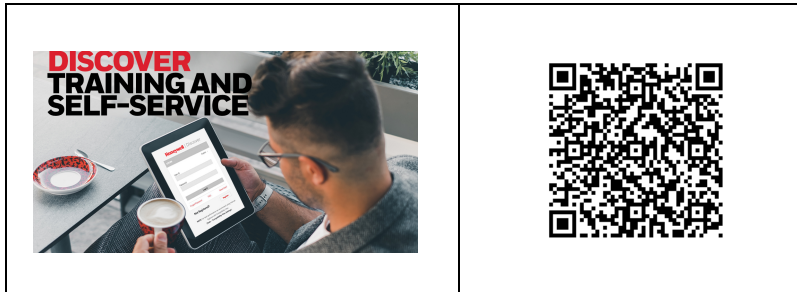

YouTube | Honeywell Help and Support

https://www.youtube.com/channel/UCBEL6ouNV_LN5IEpYRujMTg/featured

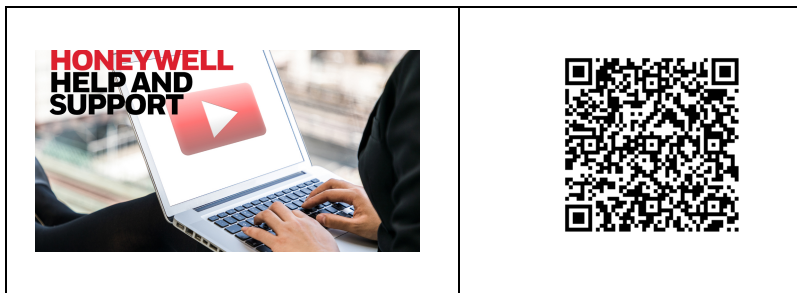

Honeywell Access Systems

135 W. Forest Hill Avenue

Oak Creek, WI 53154

United States

800-323-4576

414-766-1798 Fax

www.honeywellaccess.com

Specifications subject to change
without notice.

Document:800-25698V1

© 2020 Honeywell. All rights reserved.

Honeywell

—
**THE
FUTURE
IS
WHAT
WE
MAKE IT**