



---

ioPass SA-550 Stand-Alone Door Controller  
***Installation Manual***



---

## Warning! Please Read Carefully

### NOTE TO INSTALLERS

This warning contains vital information. As the only individual in contact with system users, it is your responsibility to bring each item in this warning to the attention of the users of this system.

### SYSTEM FAILURES

This system has been carefully designed to be as effective as possible. There are circumstances, however, involving fire, burglary, or other types of emergencies where it may not provide protection. Any access system of any type may be compromised deliberately or may fail to operate as expected for a variety of reasons. Some but not all of these reasons may be:

- **Inadequate Installation**

An access system must be installed properly in order to provide adequate protection. Every installation should be evaluated by a qualified professional to ensure that every access point is adequately controlled to the building owner's or facility management's expectations. Electric solenoid locks, magnetic locks and gate controllers should be secure and operate as intended. All latches used with the system should have adequate holding power (lb of force) and latch cavity size for the door weight type (glass, wood, steel) used. A reevaluation must be done during and after construction activity. An evaluation by the fire and/or postal carrier is recommended if this service is available. All authorized emergency personnel should be able to gain immediate access to the premises when required.

- **Criminal Knowledge**

This system contains security features which were known to be effective at the time of manufacture. It is possible for persons with criminal intent to develop techniques which reduce the effectiveness of these features. It is important that a security system be reviewed periodically to ensure that its features remain effective and that it be updated or replaced if it is found that it does not provide the protection expected.

- **Access by Intruders**

Intruders may enter through an unprotected access point, circumvent a sensing device, evade detection by moving through an area of insufficient coverage, disconnecting a device, immediately following a person through the controlled gate or door, or interfering with the proper operation of the system.

- **Power Failure**

Control units, intrusion detectors, smoke detectors and many other security devices require an adequate power supply for proper operation. If a device operates from batteries, it is possible for the batteries to fail. Even if the batteries have not failed, they must be charged, in good condition and installed correctly. If a device operates only by AC power, any interruption, however brief, will render that device inoperative while it does not have power. Power interruptions of any length are often accompanied by voltage fluctuations which may damage electronic equipment such as a security system. After a power interruption has occurred, immediately conduct a complete system test to ensure that the system operates as intended.

- **System Users**

A user may not be able to operate the system due to permanent or temporary physical disability, inability to reach the keypad, or unfamiliarity with the correct operation. It is impor-

---

tant that all system users be trained in the correct operation of the system and that they know how to respond when prompted.

- **Warning Devices**

Warning devices such as sirens, bells, horns, or strobes may not warn people or waken someone sleeping if there is an intervening wall or door. If warning devices are located on a different level of the premise, then it is less likely that the occupants will be alerted or awakened. Audible warning devices may be interfered with by other noise sources such as stereos, radios, televisions, air conditioners or other appliances, or passing traffic. Audible warning devices, however loud, may not be heard by a hearing-impaired person.

- **Component Failure**

Although every effort has been made to make this system as reliable as possible, the system may fail to function as intended due to the failure of a component.

- **Security and Insurance**

Regardless of its capabilities, a system is not a substitute for property or life insurance. A system also is not a substitute for property owners, renters, or other occupants to act prudently to prevent or minimize the harmful effects of an emergency situation.

***NOTE: This manual shall be used in conjunction with the controller installation manual to which this device is connected; It shall be installed in NON HAZARDOUS locations only by SERVICE PERSONS.***

---

## Limited Warranty

Kantech warrants the original purchaser that for a period of twelve months from the date of purchase, the product shall be free of defects in materials and workmanship under normal use. During the warranty period, Kantech shall, at its option, repair or replace any defective product upon return of the product to its factory, at no charge for labour and materials. Any replacement and/or repaired parts are warranted for the remainder of the original warranty or ninety (90) days, whichever is longer. The original owner must promptly notify Kantech in writing that there is defect in material or workmanship, such written notice to be received in all events prior to expiration of the warranty period.

### **INTERNATIONAL WARRANTY**

The warranty for international customers is the same as for any customer within Canada and the United States, with the exception that Kantech shall not be responsible for any customs fees, taxes, or VAT that may be due.

### **WARRANTY PROCEDURE**

To obtain service under this warranty, please return the item(s) in question to the point of purchase. All authorized distributors and dealers have a warranty program. Anyone returning goods to Kantech must first obtain an authorization number. Kantech will not accept any shipment whatsoever for which prior authorization has not been obtained.

### **CONDITIONS TO VOID WARRANTY**

This warranty applies only to defects in parts and workmanship relating to normal use. It does not cover:

- 1- Damage incurred in shipping or handling;
- 2- Damage caused by disaster such as fire, flood, wind, earthquake or lightning;
- 3- Damage due to causes beyond the control of Kantech such as excessive voltage, mechanical shock or water damage;
- 4- Damage caused by unauthorized attachment, alterations, modifications or foreign objects;
- 5- Damage caused by peripherals (unless such peripherals were supplied by Kantech);
- 6- Defects caused by failure to provide a suitable installation environment for the products;
- 7- Damage caused by use of the products for purposes other than those for which it was designed;
- 8- Damage from improper maintenance;
- 9- Damage arising out of any other abuse, mishandling or improper application of the products.

Kantech's liability for failure to repair the product under this warranty after a reasonable number of attempts will be limited to a replacement of the product, as the exclusive remedy for breach of warranty. Under no circumstances shall Kantech be liable for any special, incidental, or consequential damages based upon breach of warranty, breach of contract, negligence, strict liability, or any other legal theory. Such damages include, but are not limited to, loss of profits, loss of the product or any associated equipment, cost of capital, cost of substitute or replacement equipment, facilities or services, down time, purchaser's time, the claims of third parties, including customers, and injury to property.

---

**DISCLAIMER OF WARRANTIES**

This warranty contains the entire warranty and shall be in lieu of any and all other warranties, whether expressed or implied (including all implied warranties of merchantability or fitness for a particular purpose) And of all other obligations or liabilities on the part of Kantech neither assumes nor authorizes any other person purporting to act on its behalf to modify or to change this warranty, nor to assume for it any other warranty or liability concerning this product.

This disclaimer of warranties and limited warranty are governed by the laws of the state of California, U.S.A.

**WARNING:** Kantech recommends that the entire system be completely tested on a regular basis. However, despite frequent testing, and due to, but not limited to, criminal tampering or electrical disruption, it is possible for this product to fail to perform as expected.

**OUT OF WARRANTY REPAIRS**

Kantech will at its option repair or replace out-of-warranty products which are returned to its factory according to the following conditions. Anyone returning goods to Kantech must first obtain an authorization number. Kantech will not accept any shipment whatsoever for which prior authorization has not been obtained.

Products which Kantech determines to be repairable will be repaired and returned. A set fee which Kantech has predetermined and which may be revised from time to time, will be charged for each unit repaired.

Products which Kantech determines not to be repairable will be replaced by the nearest equivalent product available at that time. The current market price of the replacement product will be charged for each replacement unit.

---

## **SA-550 Compliance Specifications**

### **FCC COMPLIANCE STATEMENT**

***CAUTION: Changes or modifications not expressly approved by Kantech could void your authority to use this equipment.***

This equipment has been tested and found to comply with the limits for a Class B digital device, pursuant to Part 15 of the FCC Rules. These limits are designed to provide reasonable protection against harmful interference in a residential installation. This equipment generates, uses and can radiate radio frequency energy and, if not installed and used in accordance with the instructions, may cause harmful interference to radio communications. However, there is no guarantee that interference will not occur in a particular installation. If this equipment does cause harmful interference to radio or television reception, which can be determined by turning the equipment off and on, the user is encouraged to try to correct the interference by one or more of the following measures:

- Re-orient the receiving antenna.
- Increase the separation between the equipment and receiver.
- Connect the equipment into an outlet on a circuit different from that to which the receiver is connected.
- Consult the dealer or an experienced radio/television technician for help.

The user may find the following booklet prepared by the FCC useful: 'How to Identify and Resolve Radio/Television Interference Problems'. This booklet is available from the U.S. Government Printing Office, Washington D.C. 20402, Stock # 004-000-00345-4.

---

### **INDUSTRY CANADA STATEMENT**

This Class B digital apparatus complies with Canadian ICES-003.

Cet appareil numérique de la classe B est conforme à la norme NMB-003 du Canada.

---

### **FCC & IC COMPLIANCE**

This device complies with Part 15 Class B of the FCC rules. Operation is subject to the following two conditions: (1) this device may not cause harmful interference, and (2) this device must accept any interference received including interference that may cause undesired operation. This class B digital apparatus meets all requirements of the Canadian Interference Causing Equipment Regulations.

---

**IC/RSS-310 STATEMENT  
(Canada, Industry Canada (IC))**

This Class B digital apparatus complies with Canadian ICES-003 and RSS-310. This device complies with Industry Canada licence-exempt RSS standard(s).

Operation is subject to the following two conditions:

- 1- this device may not cause interference, and
- 2- this device must accept any interference, including interference that may cause undesired operation of the device.

**Canada, avis d'Industrie Canada (IC)**

Le présent appareil est conforme aux CNR d'Industrie Canada applicables aux appareils radio exempts de licence. L'exploitation est autorisée suivant les deux conditions suivantes:

- (1) l'appareil ne doit pas produire de brouillage, et
  - (2) l'utilisateur de l'appareil doit accepter tout brouillage radioélectrique subi, même si le brouillage est susceptible d'en compromettre le fonctionnement.
- 

**CE COMPLIANCE NOTICE**

This product is in conformity with ROHS2 Directive, EMC Directive 2004/108/EC based on results using harmonized standards in accordance with article 10(5), R&TTE Directive 1999/5/EC based on following Annex III of the directive and LVD Directive 2006/95/EC based on results using harmonized standards. This product is labeled with CE mark as proof of compliance with the above mentioned European Directives. Also a CE declaration of conformity (DoC) for this product can be found at [www.kantech.com](http://www.kantech.com).



**CE & C-TICK COMPLIANCE**

- EN50130-4: Alarm systems. Electromagnetic compatibility. Product family standard: Immunity requirements for components of fire, intruder and social alarm systems.
  - EN55022/CISPR22/EN61000-6-3 Class B: Information technology equipment. Radio disturbance characteristics. Limits and methods of measurement.
  - EN60950: Information technology equipment - General requirements.
- 

**UL 294 COMPLIANCE NOTICE**

To comply with UL listings, the following requirements must be met:

- Use only UL listed cables suitable for the use.
  - AUL294 listed power limited supply rated for the application shall be used (12Vdc/1A).
  - The system must be installed in accordance with NFPA70 (NEC), local codes, and all authorities having jurisdiction.
-



- Model SA-RM56 must be installed within the protected premises.
- All interconnecting devices must be UL Listed and Class 2 power limited.
- The following have not been evaluated by UL: (1) Fire and Burglary features (e.g. arming, guard functions, duress, forced entry, etc.), (2) Relay-1.
- The system is intended for indoor use only.
- It is recommended to test the system once a year.
- There are no user replaceable parts in the SA-550 or SA-RM56. The lithium battery in the SA-550 controller, Power Glory Battery Tech, p/n CR2032 is to be replaced only by authorized service persons.
- The SA-550 should be mounted on top of an electrical box with wires placed inside a metal conduit connecting to the electrical box where the SA-RM56 is installed:

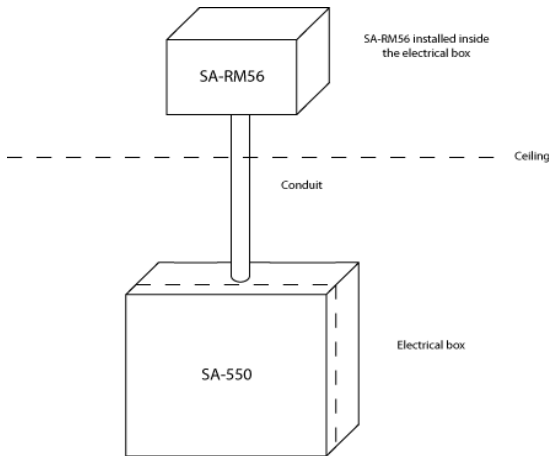

The following Kantech readers are UL1076 listed and can be used with the Kantech Model SA-550 in a UL294 compliant installation: P225W26 and P325W26.

**NOTE:** Please visit our website ([www.kantech.com](http://www.kantech.com)) for other language versions of this manual.



---

# Contents

<b>Introduction to IoPass .....</b>	<b>1</b>
Product Overview .....	1
About this Manual .....	1
Record Sheet and Worksheet .....	1
Features .....	2
Specifications .....	3
<b>Installing and Wiring IoPass™ .....</b>	<b>4</b>
Unpacking the IoPass Unit .....	4
Required Equipment .....	4
Selecting a Mounting Location .....	5
Typical Mounting Diagram .....	5
Mounting the IoPass Unit .....	6
Connecting the Door Locking Device .....	6
Connecting the T.Rex Exit Detector or Exit Button .....	7
Connecting the Door Contact .....	7
Connecting the Alarm Annunciator .....	7
Connecting the Power .....	8
<b>Programming IoPass™ - Introduction .....</b>	<b>10</b>
IoPass Programming Mode .....	10
IoPass Factory Defaults .....	11
<b>Programming IoPass™ - Features .....</b>	<b>15</b>
Access Mode Selection .....	15
Card Management .....	15
Alarm Relay Functions .....	15
Tamper Alarm Function .....	15
Forced Entry Alarm Function .....	16
Door Ajar Alarm Function .....	16
Beeper Key Tone Function .....	16
Strike Relay Activation Timer .....	16
<b>Programming IoPass™ Step by Step .....</b>	<b>17</b>
Accessing the Setup Menu .....	17
Adding & Deleting Cards .....	17
Managing Passwords .....	19
Managing Doors .....	20
Timers .....	22
The Strike Relay Timer .....	22
The Alarm Relay Timer .....	23
The Door Ajar Timer .....	23

---

---

Using the Door Ajar Function .....	24
Configuring the Tamper Alarm Function .....	24
Recommended Configuration Procedure .....	24
Enabling the Tamper Alarm Function .....	25
Using the Tamper Alarm Function .....	25
Configuring the Forced Entry Alarm .....	25
Recommended Configuration Procedure .....	26
Enabling/Disabling the Force Entry Alarm Function .....	26
Using the Force Entry Function .....	26
Configuring the Door Ajar Function .....	27
Enabling/Disabling the Door Ajar Function .....	27
Activating the Alarm Relay on Door Ajar .....	28
Selecting the Access Mode .....	28
Beeper Key Tone Configuration .....	29
Door Input Configuration .....	30
First Man Configuration .....	31
Schedules Configuration .....	31
Holidays Configuration .....	33
Language Configuration .....	34
IN/OUT Operations .....	34
USB Transfer Interface .....	37
Saving/Downloading Operation .....	37
<b>Quick Reference Programming .....</b>	<b>39</b>
<b>Table Programming Worksheet .....</b>	<b>41</b>
<b>Card Information Record Sheet .....</b>	<b>43</b>
<b>Using the IoPass™ System .....</b>	<b>45</b>
Stop Tamper Alarm .....	45
Stop Force Entry Alarm .....	46
Stop Warning Device .....	46

---

---

# Introduction to ioPass

---

## Product Overview

The ioPass is a fully programmable stand-alone access control system that allows entry using proximity technology, keypad or both, for up to 1,000 users. The configuration support up to 8 doors and the data is transferred on other units using USB keys. Compact and surface mountable, the ioPass is fully programmable directly from the keypad.

### Easy Programming

Programming is performed directly from the keypad with visual confirmation of each operation on the 16-character, 2-line LCD display.

### Higher Security SA-RM56 Concealed Relay Module

The ioPass relay module is separate from the SA-550 unit and shall be mounted within a UL listed junction box. The relay module acts as a connecting module between the ioPass unit and the system devices. Devices (door contact, strike, exit button or detector, alarm annunciator, power, etc.) are connected to this module.

## About this Manual

This Installation Manual provides installation and programming instructions for ioPass installers. Please read this manual carefully before installing or programming the ioPass unit.

**NOTE:** *User PIN required for arming/disarming the unit.*

## Record Sheet and Worksheet

You can find the **Card Information Record Sheet** on see page 43. Please photocopy this form as reference material so you can keep a record of the cards that are programmed in the ioPass unit.

You can also find a **Programming Worksheet** to record the settings that were modified within the unit. For more information, refer to the page 39.

---

## Features

- Proximity type reader with a read range up to 10.0 cm (4.0 in);
  - Capacity to store up to 1,000 user records;
  - Large 2-line LCD of 16 characters with back light feature including power saver function: the backlight will turn off if inactive for more than 3 minutes;
  - System supports up to 8 stand alone door configurations (requires 8 individual SA-550 units).
  - Three (3) access mode options:
    - Card only (default);
    - Card and PIN;
    - Card or PIN.
  - The “Alarm Relay” can be activated if:
    - the unit detects a forced entry;
    - the front cover of the unit is removed (tamper alarm function);
    - the door is opened longer than pre-set time (door ajar function).
  - Last 3500 Access Granted card numbers can be viewed on-screen;
  - Audible key tones;
  - 24 holidays and 4 access schedules;
  - 24 recurring holidays (January 1st & December 25th pre-set), 24 non-recurring holidays, 4 access schedules and 1 unlock schedule;
  - 1000 access cards;
  - Audit trail—On unit, last 3,500 transactions with time stamp;
  - Strike and alarm relay have a selectable activation timer (1-255 seconds);
  - Selectable door left open timer (1-255 seconds);
  - 6 different languages (english, french, spanish, german, dutch and italian) for the user interface;
  - Can be mounted on a standard flush mount UL Listed electrical box (vertical or horizontal positioning of the box acceptable).
-

---

## Specifications

- **Model:** SA-550;
- **Typical read range**—Up to 10.0 cm (4.0 in)<sup>1</sup>;
- **Input voltage**—12VDC;
- **Current DC maximum**—200mA. Note: The electrical ratings are for both models combined (e.g. SA-550 and SA-RM56);
- **Display**—16 characters, 2 lines, LCD with backlight;
- **Dimensions (H • W • D):**
  - cm—15.0 x 9.6x 4.0 ; in—5.9 x 3.8 x 1.6
- **Weight**—380g (13.5oz);
- **Case material**—ABS PA757 (UL 94V-0);
- **LED indicator**—Bicolor (green/red);
- **Operating temperatures**—0°C to 50°C (32°F to 122°F);
- **Operating humidity**—5% to 95% (relative humidity non-condensing);
- **Model:** SA-RM56 Relay Module;
- **Door contact input**—NO or NC selectable;
- **Request-to-Exit input**—NO or NC selectable;
- **Relay output** (Strike, Alarm and Relay-1 relay)—Form C, NO and NC, 1A, 12VDC;
- **Strike, Alarm** —1 to 255 sec.;
- **Door ajar timer**—1 to 255 sec.;
- **Compatible cards**—ioProx Card models P10SHL, P20DYE, P30DMG, P40KEY, and P50TAG;
- **Compatible readers**—P225W26 and P325W26;
- **PIN length**—4 digits;
- **Certifications**—CE, FCC, UL 294 and ICES-003.

**NOTE:** *There are no user replaceable parts in the SA-550 or SA-RM56. The lithium battery, Power Glory Battery Tech, p/n CR2032 in the SA-550 controller is to be replaced only by authorized service persons.*

**NOTE:** *Relay-1 functionality is not supported by SA-550 controller.*

**CAUTION**  
**RISK OF EXPLOSION IF BATTERY IS REPLACED BY AN**  
**INCORRECT TYPE. DISPOSE OF USED BATTERIES ACCORDING TO**  
**THE INSTRUCTIONS.**

---

1. Reduced read range with keytag and Dye-Sub cards.

---

# Installing and Wiring IoPass™

---

## Unpacking the IoPass Unit

Check that the following parts are in your ioPass package:

- One (1) ioPass unit;
- One (1) relay module (SA-RM56 including connectors);
- One (1) hardware kit;
- Ten (10) proximity keytags (P40KEY);
- One (1) ioPass, *Installation Manual* (English version).

**NOTE:** *The SA-RM56 relay module comes with all the necessary connectors to facilitate installation.*

## Required Equipment

- Power supply—12VDC, 1A (required); UL294 Listed.

**NOTE:** *The power supply shall be Class 2 power-limited, with 4 hours of standby power.*

- Cables (required):
  - **Between ioPass and reader**  
2 twisted pairs, solid conductor #22AWG UNSHIELDED
  - **Between ioPass and relay module**  
2 twisted pairs, solid conductor, #22AWG UNSHIELDED
  - **Between relay module and power supply**  
1 pair, solid conductor #18AWG UNSHIELDED

**NOTE:** *Maximum wiring distance between equipment—150m (500ft).*

- Door contact (recommended);
  - Locking device (required);
  - Door alarm or annunciator (recommended);
  - T.Rex Request-to-Exit detector (recommended).
-



## Selecting a Mounting Location

Select a mounting location for the unit using the following guidelines:

- Close to the door being supervised;
- Away from areas with a large amount of background noise;
- It is recommended that you mount the unit so that the LCD is visible to users when requesting access. The top of the unit should not be higher than 45 to 50 inches from the floor.

## Typical Mounting Diagram

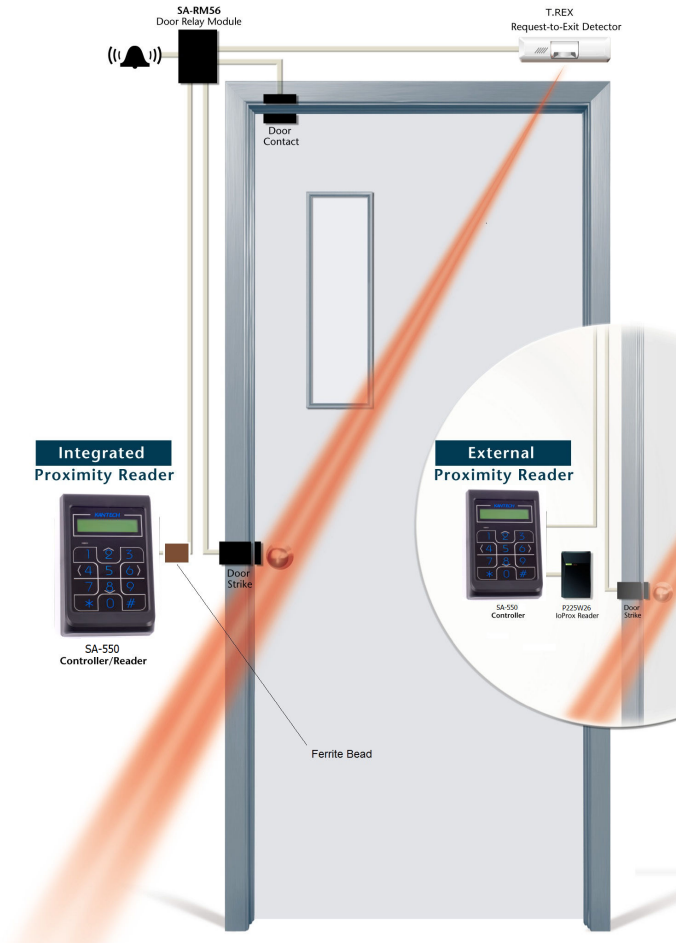

## Mounting the IoPass Unit

- 1- Remove the front panel by squeezing the sides of the unit and sliding forward;
- 2- Mount the base unit to the wall using two (2) screws (provided) to secure the unit to the standard flush mounting electrical box;
- 3- Mount the main unit to the base unit using four (4) screws (provided);
- 4- Replace the cover by gently sliding it back on the unit;
- 5- The unit offers a tamper alarm protection in case someone tries to remove the cover. For more information, please refer to "Beeper Key Tone Configuration" on page 29.
- 6- The SA-RM56 shall be mounted inside the electrical junction box and secured to the back of it using tie-wrap. The wiring connections between the SA-RM56 and the devices connected to it shall be made in mechanically protective conduit. The junction box shall be closed with its cover once all connections have been made inside the box.

## Connecting the Door Locking Device

To install the door locking device, refer to the manufacturer's instructions. To connect it, refer to the diagram below.

### Wiring Diagram

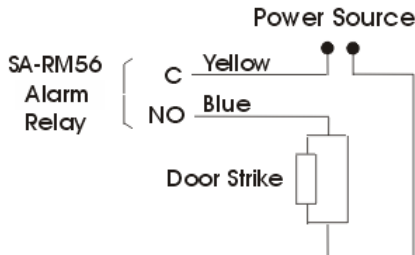

**NOTE:** Power source shall be UL294 Listed Class 2 power-limited, with 4 hours of standby power.

## Connecting the T.Rex Exit Detector or Exit Button

To install the T.Rex Exit Detector/push button, refer to the manufacturer's instructions. To connect it, refer to the diagram below.

### Wiring Diagram

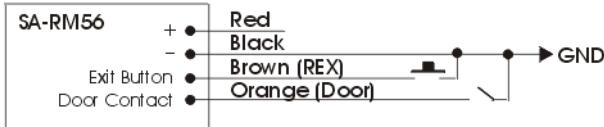

## Connecting the Door Contact

To install the door contact, refer to the manufacturer's instructions. To connect it, refer to the diagram below.

### Wiring Diagram

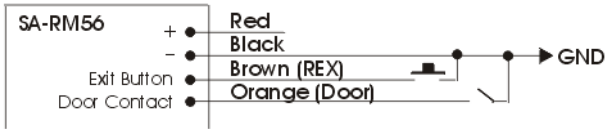

## Connecting the Alarm Annunciator

To install the alarm annunciator, refer to the manufacturer's instructions. To connect the annunciator (i.e.: horn, bell, etc.), refer to the diagram below.

**NOTE:** This feature has not been evaluated by UL.

### Wiring Diagram

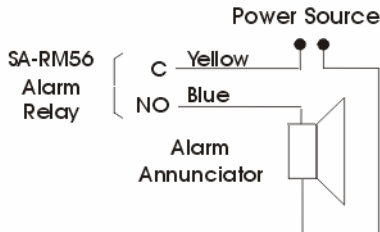

## Connecting the Power

Once all other wiring is complete, power up the unit.

### Wiring Diagram

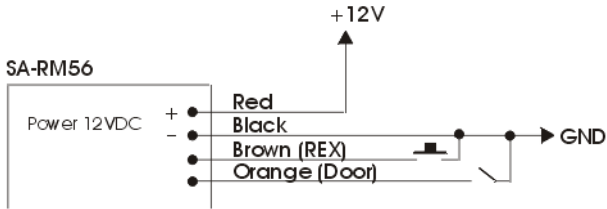

**NOTE:** Once all connections are finished, you may start to program the unit. Before you do so, we recommend reading the section called "Programming IoPass™ - Introduction" on page 10.

**NOTE:** Power source shall be UL294 Listed Class 2 power-limited, with 4 hours of standby power.

# General Wiring Diagram

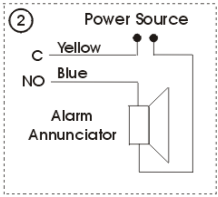
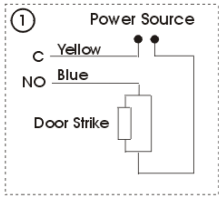
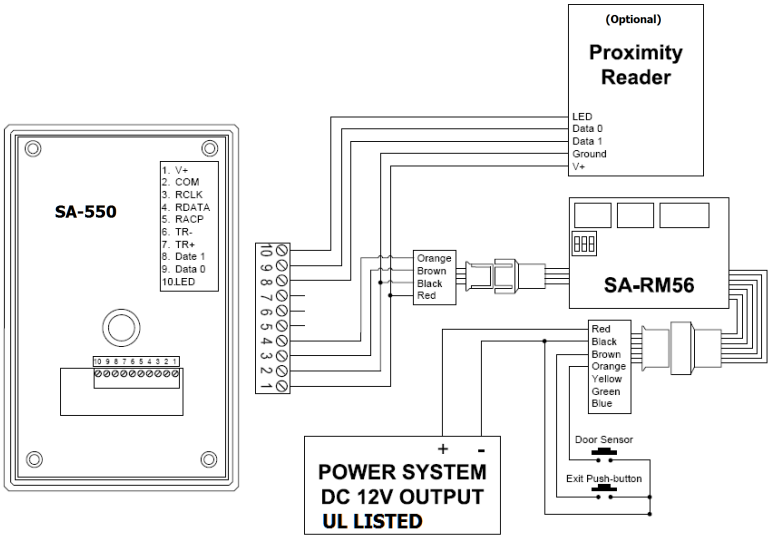

# Programming IoPass™ - Introduction

---

## IoPass Programming Mode

To enter the programming mode:

- 1- Hold the # key for two seconds.
- 2- Press 1. SET UP.
- 3- Enter the 6-digit password followed by the [#] key. The default password is [111111].

The LCD will display the following information:

1. ENROL
2. DOOR
3. TIMER
4. SYSTEM

From these basic functions, more options are available.

When programming the unit, you need to know that:

- The [\*] key is used to either go back to the previous menu, or delete what was entered.
  - The [#] key is used to accept, save the data that was modified or programmed in the system and quit.
-

## IoPass Factory Defaults

The factory defaults consist of a series of options that are automatically set up in the unit as the “basic” system configuration and can be modified.

Description	Factory Default	To Modify
Door Number	1	See p. 20
Access mode	Card only (mode 0)	See p. 28
Installer Password	111111	See p. 19
Operator Password	222222	See p. 19
Tamper alarm function	Enabled	See p. 29
Forced entry alarm function	Enabled	See p. 25
Door ajar	Enabled	See p. 27
Alarm relay activated on door ajar	Disabled	See p. 27
Beeper key tones	Enabled	See p. 29
Alarm relay activation timer when door left open more then the pre-set time (door ajar)	30 seconds (must remain open more than 30 seconds to trigger alarm relay—if the function is enabled)	See p. 27
Alarm relay active time	240 seconds (4 min.)	See p. 31
Strike relay active time	10 seconds	See p. 24
Exit button input type	Normally Open (NO)	See p. 30
Door contact type	Normally Open (NO)	See p. 30
First man entry function	Enabled	See p. 31
Recurring holiday	January 1 & December 25	See p. 33
Non-recurring holiday	No default	See p. 33
Language	English	See p. 34









---

# Programming ioPass™ - Features

---

## Access Mode Selection

Before you start registering cardholders, you **must select the suitable access mode** for your installation.

This function allows the system administrator to decide how access will be granted to cardholders. The default access mode is set to “**Mode 0 - Card Only**”.

- Mode 0 - Card Only
- Mode 1 - Card and PIN
- Mode 2 - Card or PIN

***NOTE:** For more information on access modes, refer to page 28.*

## Card Management

Up to 1,000 user cards can be registered in the ioPass unit. Depending on how many cards you need to program, you can simply add them one at a time or use the batch process to add a pre-selected batch of cards in the unit.

## Alarm Relay Functions

An alarm relay is provided on the relay module. This alarm relay can be activated by the following events:

- Tamper Alarm (if enabled)
- Forced Entry (enabled by default)
- Door Ajar (if enabled)

***NOTE:** The alarm relay is always “enabled”, but users can configure options that can trigger this relay as detailed at page 31 (default 240 seconds).*

## Tamper Alarm Function

When enabled, the tamper alarm function automatically activates the “Alarm Relay” and sounds the internal buzzer when the front panel of the unit is removed.

***NOTE:** Please refer to page 29 for more information.*

---

## Forced Entry Alarm Function

The Forced Entry Alarm Function is already enabled in the unit. This function automatically activates the “Alarm Relay” when the door contact detects unauthorized access (without card or password or both). When this occurs, a “door forced open” type of event is generated.

**NOTE:** For more information refer to page 25.

## Door Ajar Alarm Function

Already enabled in the unit, this function activates the “Alarm Relay” when the door is opened longer than the pre-set time following an access granted operation.

The user can decide if the alarm relay needs to be activated when this situation occurs.

**NOTE:** Please refer to page 27 for more information.

## Beeper Key Tone Function

This function, already enabled in the unit, provides an audible “beep” tone when the keys of the keypad are used.

**NOTE:** Please refer to page 29 for more information.

## Strike Relay Activation Timer

By default, the locking device relay is pre-set to 10 seconds, meaning that the door will remain unlocked for that period of time. The timer can be modified from 1-255 seconds.

**NOTE:** For more information refer to page 24.

---

---

# Programming IoPass™ Step by Step

---

## Accessing the Setup Menu

To access the setup menu, hold the [#] key for 2 seconds then press '1'.

**NOTE:** *The operator password allows programming all the settings EXCEPT changing the installer password and updating the firmware.*

## Adding & Deleting Cards

**NOTE:** *Once you have selected the "Access Mode", you may start enrolling cards. Otherwise, please refer to "Access Mode Selection" on page 15.*

Use the provided "Card Information Record Sheet" on page 43 to store user information (card number, name and PIN if applicable). Also, if you are using the PIN feature, you may want to gather the PIN from cardholders in advance.

All new cards must be enrolled into the unit before access is allowed. Up to 1,000 cards can be stored in the unit.

Cards are stored based on their programming sequence within the unit. If a card that is not enrolled is presented to the reader, the INVALID CARD message is displayed.

**NOTE:** *Depending on how many cards you need to program, you can simply add them one at a time or use the batch process to add a pre-selected batch of cards in the unit.*

If the maximum number of cards has been reached, the NO SPACE message will be displayed each time you attempt to add a new card.

### To add a card:

- 1- Enter the master password (default is [111111]) followed by the [#] key. The LCD displays the following:
  1. ENROL
  2. DOOR
  3. TIMER
  4. SYSTEM

2- Press [1-Enrol]. The LCD displays:

- 1-Adding cards
- 2-Deleting 3-PSW

3- Press [1-Adding cards]. The LCD displays:

TOTAL CARDS: XX (xx=# of cards in unit)  
CARD NO.\_\_:\_\_\_\_\_

4- There are two ways to enter the card number in the system:

- You can simply present the card to the reader and the number will automatically be entered.
- You can type in the number (XX:XXXXX) printed on the card followed by the [#] sign using the keypad. If you need to enter special characters (hexadecimal) see page 19.
- You may need to enter a PIN number depending on the access mode selected (see page 28 for more information). The LCD would display:

CARD NO.\_\_:\_\_\_\_\_j  
PIN:\_\_\_\_\_

5- Once you have entered the card number, you will see the following screen:

Doors: 12345678  
00000000

6- Enter 1 (valid) or 0 (not valid) below each door number to indicate for which door the entered card number is valid or not.

7- To validate your choices, press #.

8- To change the schedule associated to the selected card, press 1. Pressing 1 repeatedly will scroll through each schedule number.

9- To enable the UHOL (Unlock on Holiday) function, press 1 to display **Yes**. Otherwise, the doors will stay locked on all holidays.

10- Enter another card number or press # to exit the programming mode.

**To delete a card:**

1- Enter the master password (default is [111111]) followed by the [#] key. The LCD displays the following:

- 1. ENROL 2. DOOR
  - 3. TIMER 4. SYSTEM
-

- 2- Press [1-Enrol]. The LCD displays:
  - 1-Adding cards
  - 2-Deleting 3-PSW
- 3- Press [2-Deleting]. The LCD displays:

TOTAL CARDS: XX (xx=# of cards in unit)

CARD NO. \_\_:\_\_\_\_\_
- 4- There are two ways to enter the card number in the system:
  - You can simply present the card to the reader and the number will automatically be entered.
  - You can type in the number (XX:XXXXX) printed on the card followed by the [#] sign using the keypad. If you need to enter special characters (hexadecimal) see page 19.
- 5- To validate your choices, press #.
- 6- Enter another card number to delete or press # to exit the programming mode.

### Special Characters (Hexadecimal)

When inputting the card number using the keypad, you may need to program special characters. You can do this using hexadecimal digits. The following hexadecimal digits will insert special characters into the card number. To program a hexadecimal digit press [\*], then press the number corresponding to the hexadecimal digit.

If another hexadecimal digit is required, press [\*] again, then press the corresponding number. The ioPass reader will return to decimal programming on the next digit.

Example: To program "4E", you would enter:

- [4] - programs a "4"
- [\*][5] - programs an "E"

## Managing Passwords

**To modify the passwords:**

- 1- Enter the password (default is [111111]), then [#].
- 2- The LCD displays the following:
  1. ENROL 2. DOOR
  3. TIMER 4. SYSTEM

- 3- Press [1-ENROL]. The LCD displays the following:
  - 1-Adding cards
  - 2-Deleting 3-PSW
- 4- Press [3-PSW]. The LCD displays:
  1. Installer
  2. Operator
- 5- Select the password to be changed (Installer or Operator). The LCD displays:

Current: 111111

New:
- 6- Enter the new password. This password must be 6 characters.
- 7- Press [#] to save and exit.

## Managing Doors

### To select a door:

- 1- Enter the password (default is [111111]), then [#].
- 2- The LCD displays the following:
  1. ENROL 2. DOOR
  3. TIMER 4. SYSTEM
- 3- Press [2-DOOR]. The LCD displays the following:
  1. Door No
  2. RECORD 3. CLOCK
- 4- Press [1-Door No]. The LCD displays:

Door No. XX

NEW:
- 5- Enter a new door number. This number must be from 1 to 8.
- 6- Press [#] to save and exit.

### To review a door records:

- 1- Enter the password (default is [111111]), then [#].
  - 2- The LCD displays the following:
    1. ENROL 2. DOOR
    3. TIMER 4. SYSTEM
  - 3- Press [2-DOOR]. The LCD displays the following:
    1. Door No
    2. RECORD 3. CLOCK
-



---

4- Press [2-RECORD]. The LCD displays (for example):

Transaction # Card #

Date(Yymmdd) Time (hh:mm:ss) Door #

5- Press [#] to save and exit or [\*] to go back to the previous menu.

**To clear a door records:**

1- Enter the password (default is [111111]), then [#].

2- The LCD displays the following:

1. ENROL 2. DOOR  
3. TIMER 4. SYSTEM

3- Press [2-DOOR]. The LCD displays the following:

1. Door No  
2. RECORD 3. CLOCK

4- Press [2-RECORD]. The LCD displays:

1. Review records  
2. Clear records

5- Press [2-Clear records]. The LCD displays:

Clear all record

Press '1' to Execute

**To set the date:**

1- Enter the password (default is [111111]), then [#].

2- The LCD displays the following:

1. ENROL 2. DOOR  
3. TIMER 4. SYSTEM

3- Press [2-DOOR]. The LCD displays the following:

1. Door No  
2. RECORD 3. CLOCK

4- Press [3-CLOCK]. The LCD displays:

1. Date setting  
2. Time setting

5- Press [1-Date setting]. The LCD displays:

Date: 2012/11/21

Press '#' -> OK

6- Press [#] to exit.

---

**To set the time:**

- 1- Enter the password (default is [111111]), then [#].
- 2- The LCD displays the following:
  1. ENROL 2. DOOR
  3. TIMER 4. SYSTEM
- 3- Press [2-DOOR]. The LCD displays the following:
  1. Door No
  2. RECORD 3. CLOCK
- 4- Press [3-CLOCK]. The LCD displays:
  1. Date setting
  2. Time setting
- 5- Press [2-Time setting]. The LCD displays:

Time: 11:39

Press '#' -> OK
- 6- Press [#] to exit.

## Timers

### The Strike Relay Timer

By default, the locking device relay is pre-set to 10 seconds, meaning that the door will remain unlocked for that period of time following an "access granted" event.

The timer can be modified from 1-255 seconds.

**To set the strike relay timer:**

- 1- Enter the master password (default is [111111]) followed by the [#] key. The LCD displays the following:
    1. ENROL 2. DOOR
    3. TIMER 4. SYSTEM
  - 2- Press [3-TIMER]. The LCD displays:
    - 1.Strike 2.Alarm
    - 3.Ajar
  - 3- Press [1-Strike]. The LCD displays:

CURRENT: 10 SEC.

NEW:
-

- 4- Using the keypad, enter the number of seconds during which the locking device will be unlocked. Enter digits in “seconds”.
- 5- Press [#] to save.
- 6- Press [#] again to exit.

## The Alarm Relay Timer

By default, the alarm relay is pre-set to 240 seconds, meaning that the connected annunciator will remain activated for that period of time. The timer can be modified from 1-255 seconds.

The alarm relay can be activated by the following events:

- Tamper alarm (if enabled);
- Forced entry (enabled by default);
- Door ajar (if enabled);

**NOTE:** *This relay is always “enabled”, but options that can trigger this relay can be customized by the user.*

### To configure the alarm relay timer:

- 1- Enter the master password (default is [111111]) followed by the [#] key. The LCD displays the following:
  1. ENROL    2. DOOR
  3. TIMER    4. SYSTEM
- 2- Press [3-TIMER]. The LCD displays:
  - 1.Strike    2.Alarm
  - 3.Ajar
- 3- Press [2-Alarm]. The LCD displays:

CURRENT: 240 SEC.

NEW:
- 4- Using the keypad, enter the number of seconds during which the alarm will sound. Enter digits in “seconds”.
- 5- Press [#] to save.
- 6- Press [#] again to exit.

## The Door Ajar Timer

The door ajar timer is set to 30 seconds. If the door remains open longer than 30 seconds, after an “access” event, an alarm will sound until the door is closed correctly. If required, you can modify this setting and program a value between 1-255 seconds.

---

**To set the door ajar timer:**

- 1- Enter the master password (default is [111111]) followed by the [#] key. The LCD displays the following:
  1. ENROL    2. DOOR
  3. TIMER    4. SYSTEM
- 2- Press [3-TIMER]. The LCD displays:
  - 1.Strike    2.Alarm
  - 3.Ajar
- 3- Press [3-Ajar]. The LCD displays:

CURRENT: 30 SEC.

NEW:
- 4- Using the keypad, enter the number of seconds during which the alarm will sound. Enter digits in “seconds”.
- 5- Press [#] to save.
- 6- Press [#] again to exit.

**Using the Door Ajar Function**

Depending on whether the door ajar function is configured to trigger the alarm relay, follow this procedure to STOP the warning device.

- 1- When the door is left open, the alarm relay will be triggered OR the unit’s piezo will sound. The LCD will display:

READY FOR CARD

DOOR OPEN
- 2- The “Door Open” message is displayed (and blinking) and will remain on the LCD until the door is closed properly.

**Configuring the Tamper Alarm Function**

This tamper alarm will activate the alarm relay when the front cover of the ioPass unit is removed.

**Recommended Configuration Procedure**

- Enable tamper function;
  - Modify alarm relay timer activation (if required). See page 31 for more information.
-

---

## Enabling the Tamper Alarm Function

- 1- To enter the programming mode, enter the master password (default is [111111]) followed by the [#] key. The LCD displays the following:
  1. ENROL    2. DOOR
  3. TIMER    4. SYSTEM
- 2- Press [4-SYSTEM]. The LCD displays:
  - 1.ALARM    2.MODE
  - 3.OTHER    4.IN/OUT
- 3- Press [1-ALARM]. The LCD displays:
  - 1.Tamper    2.Force
  - 3.AJAR
- 4- Press [1-Tamper]. The LCD displays:

CURRENT: DISABLE

Press '1' --> Change
- 5- Press [1] until desired mode is displayed. Pressing this key will toggle between selections.
- 6- Press [#] to save and exit.

## Using the Tamper Alarm Function

Once the function is enabled in the system, follow this procedure to STOP the tamper alarm if it has been activated.

- 1- When the tamper alarm has been activated, the alarm relay will be triggered (usually an annunciator) and the LCD will display:

READY FOR CARD

TAMPER ALARM (blink)
- 2- This "Tamper Alarm" message is displayed (and blinking) and will remain on the LCD until an "access granted" operation is processed by the unit;
- 3- Present your card and enter your PIN or master password (depending on the system set up), access will be granted and the message will disappear.

## Configuring the Forced Entry Alarm

This function, **already enabled in the unit (default)**, will automatically activate the "Alarm Relay" when the door contact detects unauthorized

---

access (without card or password or both) or a “door forced open” type of event.

## Recommended Configuration Procedure

- Since this function is already enabled in the unit, follow the procedure below if you need to disable it (not recommended);
- Modify alarm relay timer activation (if required). See page 31 for more information.

## Enabling/Disabling the Force Entry Alarm Function

- 1- To enter the programming mode, enter the master password (default is [111111]) followed by the [#] key. The LCD displays the following:
  1. ENROL
  2. DOOR
  3. TIMER
  4. SYSTEM
- 2- Press [4-SYSTEM]. The LCD displays:
  - 1.ALARM
  - 2.MODE
  - 3.OTHER
  - 4.IN/OUT
- 3- Press [1-ALARM]. The LCD displays:
  - 1.Tamper
  - 2.Force
  - 3.AJAR
- 4- Press [2-Force]. The LCD displays:

CURRENT: ENABLE

Press '1' --> Change
- 5- Press [1] until desired mode is displayed. Pressing this key will toggle between selections.
- 6- Press [#] to save and exit.

## Using the Force Entry Function

Follow this procedure to STOP the force entry alarm if it has been activated.

- 1- When the force entry has been activated, the alarm relay will be triggered (usually an annunciator) and the LCD will display:

READY FOR CARD

FORCE ENTRY
  - 2- This “Force Entry” message is displayed (and blinking) and will remain on the LCD until an “access granted” operation is processed by the unit;
-

- 3- Present your card and enter your PIN or master password (depending on the system set up), access will be granted and the message will disappear.

## Configuring the Door Ajar Function

This function, already enabled in the unit (default), can activate the “Alarm relay” when the door is opened longer than the pre-set time following an access granted operation.

By default, the ioPass warning device will sound until the door is closed correctly. The user can decide if the alarm relay needs to be activated when this situation occurs.

## Enabling/Disabling the Door Ajar Function

- 1- Enter the master password (default is [111111]) followed by the [#] key. The LCD displays the following:
    1. ENROL
    2. DOOR
    3. TIMER
    4. SYSTEM
  - 2- Press [4-SYSTEM]. The LCD displays:
    1. ALARM
    2. MODE
    3. OTHER
    4. IN/OUT
  - 3- Press [1-ALARM]. The LCD displays:
    1. Tamper
    2. Force
    3. AJAR
  - 4- Press [3-AJAR]. The LCD displays:
    1. Ajar alarm
    2. Ajar relay
  - 5- Press [1-Ajar alarm] to enable or disable the door ajar function. The LCD displays:

CURRENT: ENABLE

Press '1' --> Change
  - 6- Press [1] until desired mode is displayed. Pressing this key will toggle between selections.
  - 7- Press [#] to save and exit. If you want the alarm relay to be activated when a “door ajar” situation occurs, follow the procedure below.
-

## Activating the Alarm Relay on Door Ajar

- 1- Enter the master password (default is [111111]) followed by the [#] key. The LCD displays the following:
  1. ENROL 2. DOOR
  3. TIMER 4. SYSTEM
- 2- Press [4-SYSTEM]. The LCD displays:
  - 1.ALARM 2.MODE
  - 3.OTHER 4.IN/OUT
- 3- Press [1-ALARM]. The LCD displays:
  - 1.Tamper 2.Force
  - 3.AJAR
- 4- Press [3-AJAR]. The LCD displays:
  - 1.Ajar alarm
  - 2.Ajar relay
- 5- Press [2-Ajar relay] to enable (trigger) or disable (not trigger) the alarm relay when the door is left open longer than pre-set time. The LCD displays:

CURRENT: DISABLE

Press '1' --> Change
- 6- Press [1] until desired mode is displayed. Pressing this key will toggle between selections.
- 7- Press [#] to save and exit.

## Selecting the Access Mode

The access mode is the most important function of the system.

Three (3) access modes are available in the system:

- **Mode "0" - Card Only - DEFAULT:** This mode only requires users to present their card to be granted access.
  - **Mode "1" - Card and PIN:** This mode requires that users present their card and then enters their PIN on the keypad. Make sure the keypad can be accessed by cardholders if you are using this mode.
  - **Mode "2" - Card or PIN:** This mode will require that users present their card to the reader to be granted access **OR** enter their PIN.
-



**To Select an Access Mode:**

- 1- Enter the password (default is [111111]), [#].

**NOTE:** *It is strongly recommended to modify the default password before programming the unit. To modify the master password, refer to "Managing Passwords" on page 19.*

- 2- The LCD displays the following:

1. ENROL 2. DOOR  
3. TIMER 4. SYSTEM

- 3- Press [4-SYSTEM]. The LCD displays:

1.ALARM 2.MODE  
3.OTHER 4.IN/OUT

- 4- Press [2-MODE]. The LCD displays:

1.Access 2.Tone  
3.DI 4. First man

- 5- Select [1-Access]. The LCD displays:

MODE: Card only  
PRESS '1' --] CHANGE

- 6- Press [1] until desired mode is displayed. Pressing this key will toggle between selections;

- 7- When the required mode is displayed (Card only, Card + PIN, Card or PIN), press [#] to save and exit.

## Beeper Key Tone Configuration

This function, already enabled in the unit (default), provides an audible "beep" tone when the keys of the keypad are used. This function is convenient when the cardholder must key in his PIN.

**To disable the beeper:**

- 1- Enter the master password (default is [111111]) followed by the [#] key. The LCD displays the following:

1. ENROL 2. DOOR  
3. TIMER 4. SYSTEM

- 2- Press [4-SYSTEM]. The LCD displays:

1.ALARM 2.MODE  
3.OTHER 4.IN/OUT

**3-** Press [2-MODE]. The LCD displays:

- 1.Access    2.Tone
- 3.DI        4. First man

**4-** Press [2-Tone]. The LCD displays:

CURRENT: ENABLE

Press '1' --> Change

**5-** Press [1] until desired mode is displayed. Pressing this key will toggle between selections. When required mode is displayed, press [#] to save and exit.

## Door Input Configuration

The ioPass unit allows the installer to configure the exit button and the door contact. These “normally open” contacts can be modified to “normally closed” to suit the installer’s requirements.

### To configure the door input:

**1-** Enter the master password (default is [111111]) followed by the [#] key. The LCD displays the following:

- 1. ENROL    2. DOOR
- 3. TIMER    4. SYSTEM

**2-** Press [4-SYSTEM]. The LCD displays:

- 1.ALARM    2.MODE
- 3.OTHER    4.IN/OUT

**3-** Press [2-MODE]. The LCD displays:

- 1.Access    2.Tone
- 3.DI        4. First man

**4-** Press [3-DI]. The LCD displays:

- 1.Exit button
- 2.Door contact

**5-** Press [1-Exit button] to modify the exit button polarity OR press [2-Door] to modify the door contact polarity. In either cases, the LCD displays:

CURRENT: NC

Press '1' --> Change

**6-** Press [1] until desired mode is displayed. Pressing this key will toggle between selections. When required mode is displayed, press [#] to save and exit.

---

---

## First Man Configuration

The ioPass unit allows the installer to configure the first man entry function. This way, the door schedule will be enable only once the first user with a valid card is granted access.

### To configure the first man access:

- 1- Enter the master password (default is [111111]) followed by the [#] key. The LCD displays the following:
  1. ENROL    2. DOOR
  3. TIMER    4. SYSTEM
- 2- Press [4-SYSTEM]. The LCD displays:
  - 1.ALARM    2.MODE
  - 3.OTHER    4.IN/OUT
- 3- Press [2-MODE]. The LCD displays:
  - 1.Access    2.Tone
  - 3.DI        4. First man
- 4- Press [3-First man]. The LCD displays:

CURRENT: ENABLE

Press '1' --> Change
- 5- Press [1] until desired mode is displayed. Pressing this key will toggle between selections. When required mode is displayed, press [#] to save and exit.

## Schedules Configuration

From this menu, you can configure access and unlock schedules. An access schedule defines the access times for users with cards. An unlock schedule defines the access times for the general public.

### To configure a schedule:

- 1- Enter the master password (default is [111111]) followed by the [#] key. The LCD displays the following:
    1. ENROL    2. DOOR
    3. TIMER    4. SYSTEM
  - 2- Press [4-SYSTEM]. The LCD displays:
    - 1.ALARM    2.MODE
    - 3.OTHER    4.IN/OUT
-

**3-** Press [3-OTHER]. The LCD displays:

- 1.SCHEDULES
- 2.HOLIDAYS    3. Language

**4-** Press [1-SCHEDULES]. The LCD displays:

- 1.Access schedule
- 2.Unlock schedule

**5-** Press [1-Access schedule], the LCD displays:

```
SD      I  START  END
01      1  00:00 - 24:00
```

or Press [2-Unlock schedule], the LCD displays:

```
DN      I  START  END
01      1  00:00 - 24:00
```

SD: Schedule number (up to 4 schedules).

DN: Door Number (up to 8 doors).

I: Interval number (up to 4 intervals).

START: Time at which the schedule is valid.

END: Time at which the schedule is no more valid.

**6-** Use the up and down arrows to scroll between schedule numbers.

**7-** Press the right arrow to move to the interval. Use the up arrow to scroll between interval numbers.

**8-** Press the [#] key to move to the start time.

**9-** Enter the start and end times using the keypad digits.

**10-** Press the [#] key to go to the next menu. The LCD displays:

```
DAYS    S M T W T F S
02 1    0 0 1 1 1 0 0
```

**11-** Enter 1 for each day the schedule is valid or 0 for each day the schedule is not valid.

**12-** Press the [#] go back to the previous menu.

**13-** Press the [#] to exit.

---

---

## Holidays Configuration

### To configure a holiday:

- 1- Enter the master password (default is [111111]) followed by the [#] key. The LCD displays the following:
  1. ENROL 2. DOOR
  3. TIMER 4. SYSTEM
- 2- Press [4-SYSTEM]. The LCD displays:
  - 1.ALARM 2.MODE
  - 3.OTHER 4.IN/OUT
- 3- Press [3-OTHER]. The LCD displays:
  - 1.SCHEDULES
  - 2.HOLIDAYS 3. Language
- 4- Press [2-HOLIDAYS]. The LCD displays:
  - 1.Recurring
  - 2.Non-recurring
- 5- Press [1-Recurring], the LCD displays:

HOL	[DATE]
01	January- 01

or press [2-Non-recurring], the LCD displays:

HOL	[DATE]
01	Month- 00

HOL: Holiday number (up to 24 holidays).

DATE: Month and day of the holiday.

**Recurring holidays:** For those holidays that recur at the same day of every year; once configured, they always remain valid. January 01 pre-set at Holiday 01 & December 25 pre-set at Holiday 21.

**Non-recurring holidays:** For those holidays that are not fixed in relation to the calendar, for example Easter. Once configured, they are valid only once and will be automatically cleared after December 31; therefore configuring non-recurring holidays each year is required if using this function.

- 6- Use the up arrow to scroll between holiday numbers.
-

- 7- Press the right arrow to move to the month selection. Use the up and down arrows to scroll between months.
- 8- Press the right arrow to move to the day. Use the up and down arrows to scroll between days of the month.
- 9- Press the [\*] to go back to the previous menu. From there you can configure another holiday.
- 10- Press the [#] to exit.

## Language Configuration

### To change the user interface language:

- 1- Enter the master password (default is [111111]) followed by the [#] key. The LCD displays the following:
  1. ENROL    2. DOOR
  3. TIMER    4. SYSTEM
- 2- Press [4-SYSTEM]. The LCD displays:
  - 1.ALARM    2.MODE
  - 3.OTHER    4.IN/OUT
- 3- Press [3-OTHER]. The LCD displays:
  - 1.SCHEDULES
  - 2.HOLIDAYS    3. Language
- 4- Press [3-LANGUAGE]. The LCD displays:

ENGLISH

Press '1' --> Change
- 5- Press [1] until desired language is displayed. Pressing this key will toggle between selections. When required language is displayed, press [#] to save and exit.

## IN/OUT Operations

**NOTE:** Before performing any action in that section please locate the USB port on the right side of the unit. Insert a USB key formatted in Fat32 format with a 32MB free space. For more information on how to use the USB transfer interface, please refer to **USB Transfer Interface** on page 37.

---

---

**Loading/saving the device configuration:**

- 1- Enter the master password (default is [111111]) followed by the [#] key. The LCD displays the following:
  1. ENROL    2. DOOR
  3. TIMER    4. SYSTEM
- 2- Press [4-SYSTEM]. The LCD displays:
  - 1.ALARM    2.MODE
  - 3.OTHER    4.IN/OUT
- 3- Press [4-IN/OUT]. The LCD displays:
  - 1.CONFIG    2.CARD
  - 3.Report    4.Upgrade
- 4- Press [1-CONFIG]. The LCD displays:
  - 1.Load to Unit
  - 2.Save to USB
- 5- Press [1-Load to Unit] to load a configuration into the unit (from a USB drive) or [2-Save to USB] to save the unit configuration to a USB drive.

**Loading/saving card data:**

- 1- Enter the master password (default is [111111]) followed by the [#] key. The LCD displays the following:
    1. ENROL    2. DOOR
    3. TIMER    4. SYSTEM
  - 2- Press [4-SYSTEM]. The LCD displays:
    - 1.ALARM    2.MODE
    - 3.OTHER    4.IN/OUT
  - 3- Press [4-IN/OUT]. The LCD displays:
    - 1.CONFIG    2.CARD
    - 3.Report    4.Upgrade
  - 4- Press [2-CARD]. The LCD displays:
    - 1.Load to Unit
    - 2.Save to USB
  - 5- Press [1-Load to Unit] to load cards data into the unit (from a USB drive) or [2-Save to USB] to save cards data to a USB drive.
-

**Issuing an event report:**

- 1- Enter the master password (default is [111111]) followed by the [#] key. The LCD displays the following:
  1. ENROL 2. DOOR
  3. TIMER 4. SYSTEM
- 2- Press [4-SYSTEM]. The LCD displays:
  - 1.ALARM 2.MODE
  - 3.OTHER 4.IN/OUT
- 3- Press [4-IN/OUT]. The LCD displays:
  - 1.CONFIG 2.CARD
  - 3.Report 4.Upgrade
- 4- Plug a USB drive into the unit. If no drive is connected to the unit, the message "Disk not found, Please Insert" will be displayed.
- 5- Press [3-Report]. The LCD displays:

Saving.....xx%

**Upgrade the unit with a new firmware:**

- 1- Enter the master password (default is [111111]) followed by the [#] key. The LCD displays the following:
    1. ENROL 2. DOOR
    3. TIMER 4. SYSTEM
  - 2- Press [4-SYSTEM]. The LCD displays:
    - 1.ALARM 2.MODE
    - 3.OTHER 4.IN/OUT
  - 3- Press [4-IN/OUT]. The LCD displays:
    - 1.CONFIG 2.CARD
    - 3.Report 4.Upgrade
  - 4- Press [4-Upgrade]. The LCD displays:

Firmware upgrade  
Press '1' to Execute
-



---

## USB Transfer Interface



### Saving/Downloading Operation

- 1- Find the USB port on the right side of the SA-550 reader.
- 2- Plug a USB drive (FAT32).

**NOTE:** A USB drive with a capacity of 512MB minimum (formatted in FAT32) is recommended for transferring the database to and from the reader.

- 3- Press the # key for 2 seconds.
- 4- Press [1-SET UP].
- 5- Enter your password (default is 111111).
- 6- Press the # key.
- 7- Select [4-SYSTEM].
- 8- Select [4-IN/OUT].

**NOTE:** To access section 4-IN/OUT, you will need to plug a USB drive into the port.

---

**Doors**

- 1- Select [1-CONFIG].
- 2- To download door configurations from the USB drive, select [1-Load to Unit]. The LCD displays:  
Loading.... xx%
- 3- To upload door configurations to the USB drive, select [2-Save to USB]. The LCD displays:  
Saving.... xx%

**Cards**

- 1- Select [2-CARD].
- 2- To download cards from the USB drive, select [1-Load to Unit]. The LCD displays:  
Loading.... xx%
- 3- To upload cards to the USB drive, select [2-Save to USB]. The LCD displays:  
Saving.... xx%

**NOTE:** *The transferred file cannot be edited.*

**Reports**

- 1- Select [3-Report] to automatically upload a report to the USB drive. The LCD displays:  
Saving.... xx%

**Firmware Upgrade**

**NOTE:** *A backup of the database should be performed before proceeding with the upgrade.*

- 1- Select [4-Upgrade]. The LCD displays:  
Firmware upgrade  
Press '1' to execute
-

# Quick Reference Programming

# (hold 2 seconds)					
	0. Check Version				
	1. Set up				
		Password: (default 111111)			
		<b>1. ENROL</b>			
		1. Adding Cards			
			TOTAL CARDS:		
			CARD NO.:	(Enter card number + #, optional, see <b>Selecting the Access Mode</b> )	
			Doors:	12345678 00000000	Schedule: Press '1' -> Change
					U/HOL: Press '1' -> Change
		2. Deleting Cards			
			CARD NO.:	(Card number + #)	
		3. PSW(Passwrod)			
			1. Installer		
				CURRENT: 111111(default)	
				NEW:	
			2. Operator		
				CURRENT: 222222(default)	
				NEW:	
	<b>2. DOOR</b>				
		1. Door No.			
			Door No.		
			NEW:		
		2. RECORD			
			1. Review records		
				1 10:14045 110810 141213 04	
			2. Clear Records		
				Clear all records Press '1' to Execute	
		3. CLOCK			
			1. Date Setting		
				DATE: Press '#' -> OK	
			2. Time Setting		
				TIME: Press '#' -> OK	
	<b>3. TIMER</b>				
		1. Strike			
			CURRENT:		
			NEW:		
		2. Alarm			
			CURRENT:		
			NEW:		
		3. Ajar			
			CURRENT:		
			NEW:		

<b>4. SYSTEM</b>	
1. ALARM	
1. Tamper	CURRENT: Press '1' --> Change
2. Force	CURRENT: Press '1' --> Change
3. AJAR	
1. Ajar alarm	CURRENT: Press '1' --> Change
2. Ajar relay	CURRENT: Press '1' --> Change
2. MODE	
1. Access	CURRENT: Press '1' --> Change
2. Tone	CURRENT: (ENABLED/DISABLED) Press '1' --> Change
3. DI	
1. Exit button	CURRENT: Press '1' --> Change
2. Door contact	CURRENT: Press '1' --> Change
4. First man	CURRENT: (ENABLED/DISABLED) Press '1' --> Change
3. OTHER	
1. SCHEDULES	
1. Access schedule	SD   Start End 00 1 00:00-00:00 DAYS: SMTWTFS 01 1 1111111
1. Unlock schedule	DN   Start End 00 1 00:00-00:00 DAYS: SMTWTFS UL 1 1111111
2. HOLIDAYS	
1. Reccurring	Hol [DATE] 00 Month dd
2. Non-recurring	Hol [DATE] 00 Month dd
3. Language	ENGLISH Press '1' --> Change
4. IN / OUT	
1. CONFIG	
1. Load to Unit	Loading..... xx%
2. Save to USB	Saving..... xx%
2. CARD	
1. Load to Unit	Loading..... xx%
2. Save to USB	Saving..... xx%
3. Report	Saving..... xx% Generate Events.csv file
4. Upgrade	Firmware upgrade Press '1' to Execute

---

# Table Programming Worksheet

---

## Access Mode

---

[4]-[2]-[1]

Mode "0" - Card only (DEFAULT)

Mode "1" - Card and PIN

Mode "2" - Card **OR** PIN

## Timers

---

Timers	Default	New
Strike [3]-[1]	10 seconds	_ _ _
Alarm [3]-[2]	10 seconds	_ _ _
Ajar [3]-[3]	20 seconds	_ _ _

**NOTE:** Allowed from 1 to 255 seconds.

---

---

**System Functions**

---

**NOTE:** For more information, see "IoPass Factory Defaults" on page 11.

Functions	YES	NO
Tamper alarm [4]-[1]-[1]	<input type="checkbox"/>	<input type="checkbox"/>
Door forced open [4]-[1]-[2]	<input type="checkbox"/>	<input type="checkbox"/>
Door ajar [4]-[1]-[3]	<input type="checkbox"/>	<input type="checkbox"/>
Alarm relay activated on door ajar [4]-[1]-[3]-[2]	<input type="checkbox"/>	<input type="checkbox"/>
Tone/beeper [4]-[2]-[2]	<input type="checkbox"/>	<input type="checkbox"/>
Door contact type [4]-[2]-[3]-[2] NO <input type="checkbox"/> NC <input type="checkbox"/>		
Exit button contact type [4]-[2]-[3]-[1] NO <input type="checkbox"/> NC <input type="checkbox"/>		

---







---

# Using the IoPass™ System

---

By default, the LED (indicator) is red, and the LCD of the ioPass unit displays:

READY FOR CARD

You may have been given an access card or an access card and a PIN for the secured area. Depending on how the system is configured, the procedure remains the same:

- 1- Depending on the selected access mode (see page 28 for more information), the procedure can be one of the followings:
  - **Mode “0” - Card Only:** Present your card at the reader;
  - **Mode “1” - Card and PIN:** Present your card at the reader and enter the 4-digit PIN followed by the [#] key;
  - **Mode “2” - Card or PIN:** Present your card at the reader or press the [\*] key and enter the 4-digit PIN followed by the [#] key.
- 2- If you key in an incorrect password, the system will display “Invalid PIN”. In this case, start from step 1. Otherwise, the LCD displays:

ACCESS GRANTED

The door will unlock and the LED (indicator) will turn green.

**NOTE:** Do not give your PIN to anybody.

## Stop Tamper Alarm

Follow this procedure to STOP the tamper alarm if it has been activated:

- 1- When the tamper alarm has been activated, the alarm relay will be triggered (usually an annunciator) and the LCD will display:

READY FOR CARD  
TAMPER ALARM (blink)
  - 2- This “Tamper Alarm” message is displayed and blinking and will remain on the LCD until an “access granted” operation is processed by the unit;
  - 3- Present your card and enter your PIN (depending on the system set up) followed by the [#] key. Access will be granted and the message will disappear.
-

## Stop Force Entry Alarm

Follow this procedure to STOP the force entry alarm if it has been activated.

- 1- When the force entry has been activated, the alarm relay will be triggered (usually an annunciator) and the LCD will display:  
READY FOR CARD  
FORCE ENTRY
- 2- This “Force Entry” message is displayed (and blinking) and will remain on the LCD until an “access granted” operation is processed by the unit;
- 3- Present your card and enter your PIN (depending on the system set up) followed by the [#] key. Access will be granted and the message will disappear.

## Stop Warning Device

Depending on whether the door ajar function is configured to trigger the alarm relay, follow this procedure to STOP the warning device.

- 1- When the door is left open, the alarm relay might not trigger but the unit’s piezo will always sound. The LCD will display:  
READY FOR CARD  
DOOR OPEN
  - 2- The “Door Open” message is displayed (and blinking) and will remain on the LCD until the door is closed properly.
-



# **KANTECH**

*A Tyco International Company*

© 2013 Tyco International Ltd. and its Respective Companies. All Rights Reserved. [www.kantech.com](http://www.kantech.com)

---

DN2076-1309



**029008443R003**