

# CAT 6A 110-Type 10G Patch Panel, 48-Port, 2 RMS

## Package Includes:

- A. 48-Port CAT 6A UTP Patch Panel, **1 Piece**
- B. #12-24 x 5/8" Pan Head, Pilot Point Machine Screw, **4 Pieces**
- C. Installation Instructions, **1 Sheet**



## Features and Benefits

- Vertical 110-Type IDC connections reduces potential Alien Crosstalk (ANXT)
- Enhanced crosstalk cancellation and reduced return loss for high bandwidth network requirements
- Exceeds ANSI/TIA-568 CAT 6A (10G) connecting hardware Component Rating requirements
- 110-Type IDC termination help reduce installation time and improve wire retention
- 50 micro inch gold plating on all modular contacts to protect from corrosion
- Mounts on industry standard 19" wide racks or equipment
- T568A or T568B wiring schemes; not compatible with 110-type patch plug
- UL® listed
- Country of Origin: Taiwan
- TAA Compliant

# Specifications

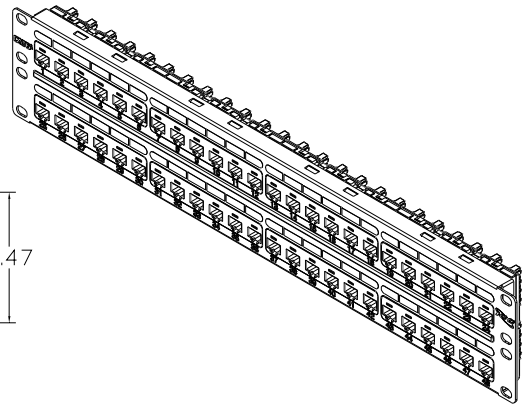
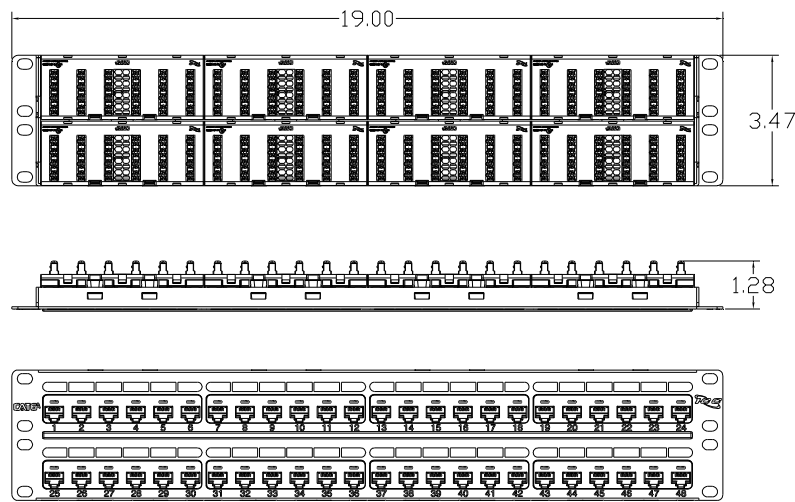
**NOTE: UNLESS OTHERWISE SPECIFIED**

1. MEETS TIA/EIA-568-C.2 CAT 6A CONNECTING HARDWARE REQUIREMENTS
2. ENVIRONMENTAL CONDITIONS:
  - A. TEMPERATURE RANGE  
STORAGE: -40° TO +70°C  
OPERATIONAL: -10° TO +60°C  
RELATIVE HUMIDITY (OPERATIONAL): MAXIMUM NONCONDENSING 93%
3. ELECTRICAL:
  - A. ELECTRICAL INSULATION RESISTANCE: 500 MOHMS MIN @ 100V DC
  - B. DIELECTRIC WITHSTANDING VOLTAGE: 1000V DC OR AC PEAK CONTACT @ 60Hz FOR 1 MINUTE
  - C. SPRING WIRE CONTACT RESISTANCE: 20 MOHMS MAX.
  - D. IDC CONTACT RESISTANCE: 2.5 MOHMS MAX.
4. MECHANICAL:
  - A. RETENTION: 50N (11 LBS SQ) OR 60S±5S
  - B. INSERTION/EXTRACTOR: 750 CYCLES MIN.
  - C. IDC WIRE GAUGE: 22~24 AWG
5. PHYSICAL:
  - A. HOUSING: ZINC ALLOY FULLY SHIELDED
  - B. MARKING: MOLD UL INFORMATION
  - C. SPRING WIRE: PHOSPHOR BRONZE ALLOY PLATED WITH 50 MICRO-INCH OF GOLD OVER 70~100 MICRO-INCH OF NICKEL
  - D. IDC: PHOSPHOR BRONZE ALLOY WITH 100 MICRO-INCH 100% Sn ALLOY



For warranty information, go online to [icc.com/warranty](http://icc.com/warranty).

Part No: ICMP0486B Rev: A

Part No: ICMP0486B

Rev: A

Page 2 of 2

| 888-ASK-4ICC | [icc.com](http://icc.com) | [csr@icc.com](mailto:csr@icc.com) |

