

Concrete Floor/Wall Rack Install Kit

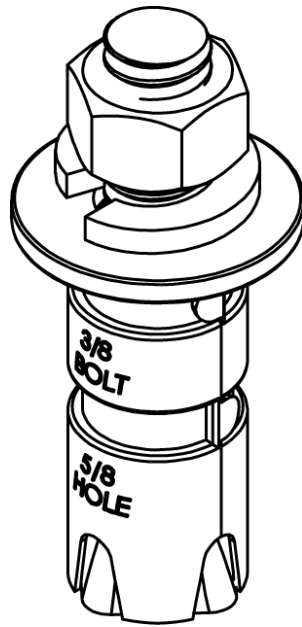

Package Include:

- A. 3/8-16 Expansion Anchor, **4 Piece**
- B. 3/8 x 2.25" Threaded Rod, **4 Piece**
- C. 3/8 Flat Washer (O.D. 1"), **4 Piece**
- D. 3/8-16 Hex Nut, **4 Piece**
- E. 3/8 Split Lock Washer, **4 Piece**

Features and Benefits

- Designed to securely anchor ICC's Distribution Rack and Cable Management Rack to concrete block, brick, and stone.
- Strong and durable with the capacity to withstand 1200 lbs of tension load when installed as a kit
- Recommend for floor mounting but can be used as wall mountable
- Flush mountable; Facilitates M.A.C.
- Rust-resistant
- Caulking not required which allows for anchor to be removed after service.

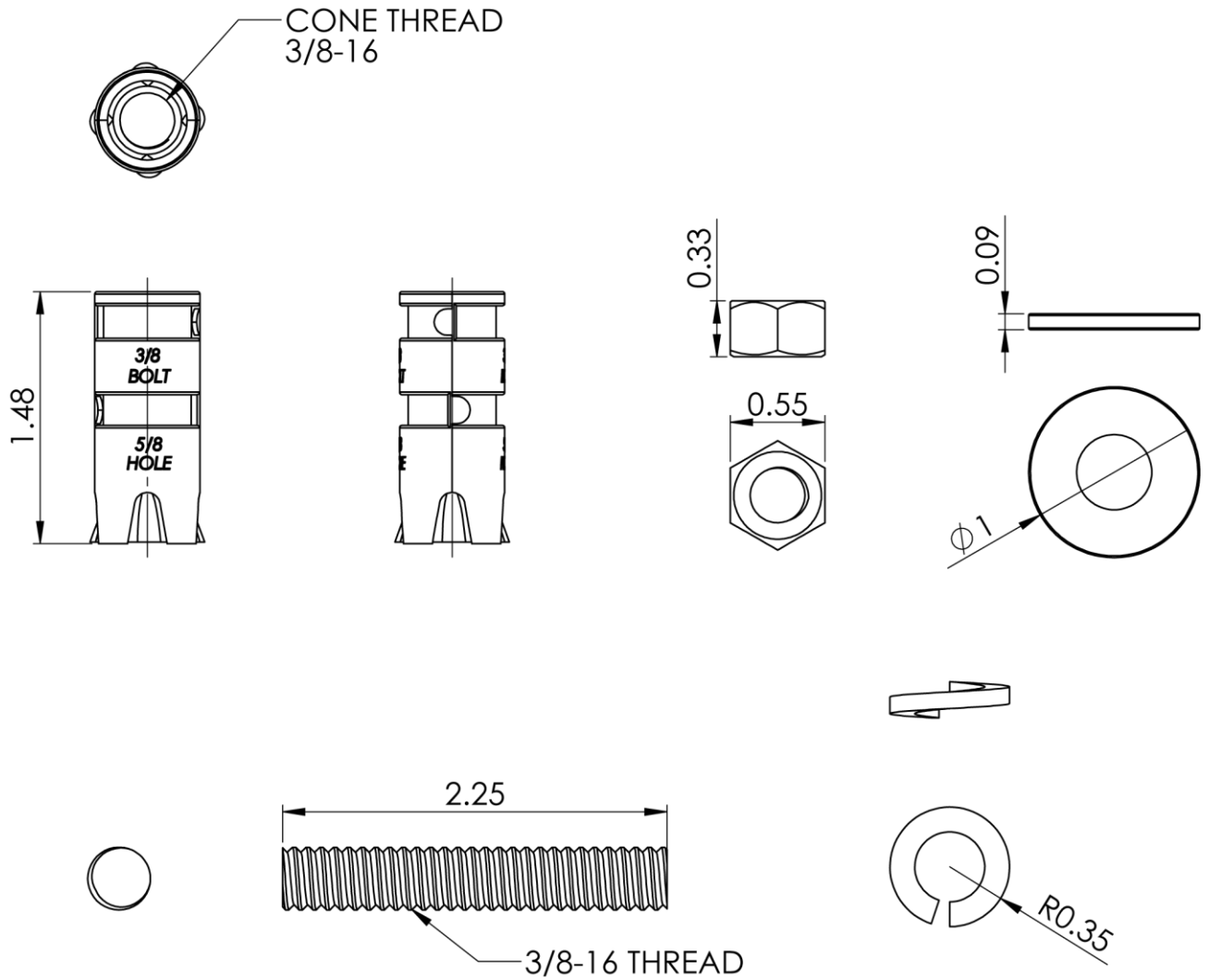

Specifications

- Material:
 - Anchor: Zamak Alloy
- Thread: 3/8-16
- Load Capacity: 1200 LBS

