

Vertical Cable Management Ring, 1.25", 10 Pack



Package Includes:

- A. Vertical Cable Management Ring, **10 Pieces**
- B. Mounting Screws, **20 Pieces**

Features and Benefits

- Provides flexibility for front or back cable management with a neat and clean appearance
- Suitable for all racks, wall mount racks, and wall mount brackets
- Used with ICCMS distribution and cable management racks, ICCMSWMR wall mount racks, ICCMSSFR wall mount swing gate racks, ICCMSVHB wall mount vertical hinged brackets, and ICCMSHB wall mount hinged brackets
- Country of Origin: Taiwan
- TAA Compliant

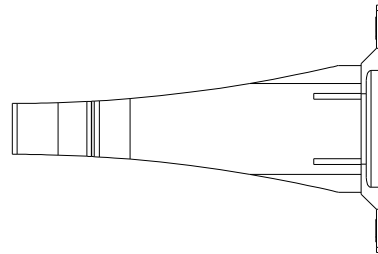
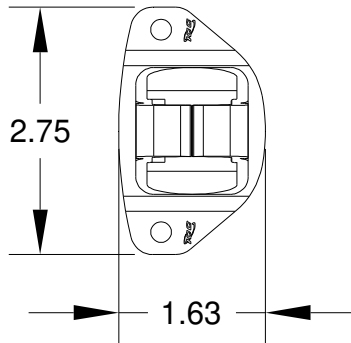
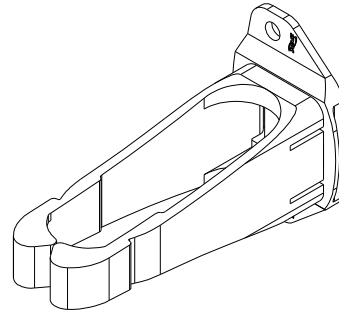
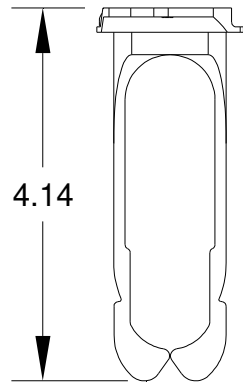

NOTE: UNLESS OTHERWISE SPECIFIED

1. Material: High Impact ABS, UL 94V-0
2. Color: Black