

3.00" Universal Cable Management Ring



Package Includes:

- A. 3" Double Universal Cable Management Ring, **1 Pieces**
- B. #12-24 x 5/8" Pan Head, Pilot Point Machine Screw, Mounting Screws, **2 Pieces**

Features and Benefits

- Provides flexibility for front or back cable management with a neat and clean appearance
- Suitable for all racks, wall mount racks, and wall mount brackets
- Used with ICCMS distribution and cable management racks, ICCMSWMR wall mount racks, ICCMSSFR wall mount swing gate racks, ICCMSVHB wall mount vertical hinged brackets, and ICCMSHB wall mount hinged brackets.
- Country of Origin: Taiwan
- TAA Compliant

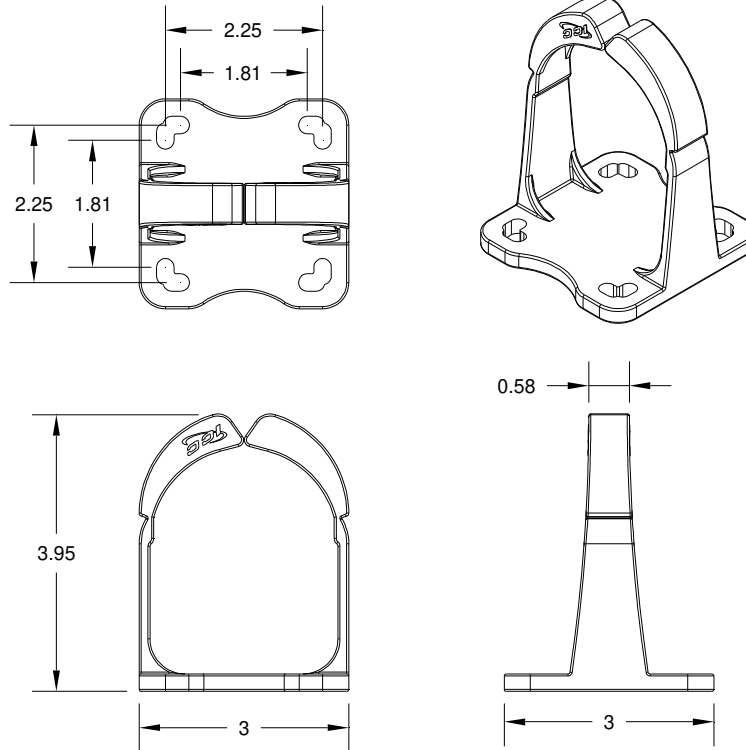

NOTE: UNLESS OTHERWISE SPECIFIED

1. Material: High Impact ABS, UL 94V-0
2. Color: Black