

GV-Recording Server

User's Manual





© 2021 GeoVision, Inc. All rights reserved.

Under the copyright laws, this manual may not be copied, in whole or in part, without the written consent of GeoVision.

Every effort has been made to ensure that the information in this manual is accurate. GeoVision, Inc. makes no expressed or implied warranty of any kind and assumes no responsibility for errors or omissions. No liability is assumed for incidental or consequential damages arising from the use of the information or products contained herein. Features and specifications are subject to change without notice.

GeoVision, Inc.
9F, No. 246, Sec. 1, Neihu Rd.,
Neihu District, Taipei, Taiwan
Tel: +886-2-8797-8377
Fax: +886-2-8797-8335
<http://www.geovision.com.tw>

Trademarks used in this manual: *GeoVision*, the *GeoVision* logo and *GV* series products are trademarks of GeoVision, Inc. *Windows* is the registered trademark of Microsoft Corporation.

October 2021

Scan the following QR codes for product warranty and technical support policy:



[Warranty]



[Technical Support Policy]

Preface

Welcome to the *GV-Recording Server User's Manual*.

This Manual is designed for the following version:

Product	Version
GV-Recording Server / GV-Video Gateway	V2.0.0

GDPR Practice

For details on how GeoVision Inc. is committed to helping users become GDPR (General Data Protection Regulation) compliant, visit the [GDPR Consent Request](#).

Contents

Preface	i
GDPR Practice	i
Naming and Definition	vi
Chapter 1 Introduction	1
1.1 System Requirements	6
1.1.1 Minimum System Requirements.....	6
1.1.2 GV-USB Dongle	7
1.1.3 Compatible Versions of GeoVision Applications	8
1.1.4 Recommended Hard Disk Requirements	9
1.1.5 Recommended Network Requirements.....	10
1.1.6 Requirements for Connecting to GV-Backup Center	11
Chapter 2 Installation	12
2.1 Installing GV-Recording Server	12
2.2 Starting GV-Recording Server	13
Chapter 3 Getting Started	16
Chapter 4 Active and Passive Mode	21
4.1 Active Connection	22
4.2 Passive Connection.....	22
Chapter 5 Administrator Mode	25
5.1 Information	27
5.1.1 Camera Connection Information.....	27
5.1.2 Storage Information.....	29
5.1.3 Client Connection Information	30
5.1.4 Server Information.....	30
5.2 Camera	31
5.2.1 Install Camera.....	31
5.2.2 Camera Setting	36

5.2.3 Motion Detection	44
5.3 Server.....	46
5.3.1 Service.....	46
5.3.2 Install Wizard	46
5.3.3 General Setup.....	47
5.3.4 Storage Path.....	49
5.3.5 Video Gateway.....	50
5.3.6 Notification	53
5.4 Network.....	55
5.4.1 Network.....	55
5.4.2 Port Setting	57
5.4.3 Mail Service	58
5.4.4 Remote ViewLog.....	60
5.4.5 SNMP	61
5.5 Advanced Management.....	62
5.5.1 E-map	62
5.5.2 GIS.....	65
5.5.3 VSM.....	66
5.5.4 Backup Center	68
5.5.5 Failover Server.....	69
5.5.6 GV-PoE Switch	70
5.5.7 GV-Cloud Center.....	71
5.5.8 Live Stream Sharing.....	72
5.5.9 User Account	74
5.5.10 Advanced Query	75

Chapter 6 User Mode.....76

6.1 Single Live View.....	77
6.1.1 Control Panel	78
6.1.2 Snapshot of a Live Video	79
6.1.3 Video Recording.....	79
6.1.4 Picture-in-Picture and Picture-and-Picture View.....	80
6.1.5 PTZ Control.....	82
6.1.6 Visual PTZ	83
6.1.7 Image Enhancement	84
6.1.8 GPS Tracking.....	85
6.2 Multi-Channel Live View	87
6.3 Emap Query	88

6.4 Remote Playback	89
6.4.1 Event List Query.....	89
6.4.2 Preview Query	90
6.5 Composite Information Query.....	91
6.6 System Log Query.....	92
6.7 Behavior Log Query.....	93
6.8 Login / Logout Query	94
6.9 Stat Chart	95
6.10 System Analysis Report	96
Chapter 7 Connections with Clients	97
7.1 Connecting with GV-DVR / NVR.....	97
7.2 Connecting with Multi View.....	100
7.3 Connecting with Multicast.....	102
7.4 Connecting with GV-VMS	103
7.5 Connecting with Remote ViewLog	106
7.6 Connecting with GV-Control Center.....	108
7.7 Connecting with GV-Mobile Server.....	109
7.8 Connecting with GV-Edge Recording Manager	111
Chapter 8 Useful Utilities	112
8.1 Windows Lockup	112
8.1.1 The GV-Desktop Screen	112
8.1.2 The GV-Desktop Screen	113
8.2 Recording Server Management Tool	115
8.2.1 GV-Recording Server Management Tool Main Screen.....	115
8.2.2 Adding GV-Recording Server Hosts	116
8.2.3 System Analysis Report	117
Specifications	118
Appendix	119
A. Settings for Internet Explorer 8 or later.....	119
B. RTSP Protocol Support.....	120
C. Installing the Internal USB Dongle	121

D. How to Avoid Network Bottleneck	123
E. How to Repair the Storage Path.....	124
F. Installing .Net Framework 3.5 for Windows Server 2012 and Windows 8	125
G. Setting Live Streaming on YouTube	128

Naming and Definition

GV-Backup Center	GeoVision Backup Center software provides a secure and affordable remote backup solution for GV-Recording Server and other GV-Software / IP Devices. A GV-Backup Center can only connect to one GV-Recording Server at a time.
GV-Control Center	GeoVision Control Center is a central monitoring software that allows you to remotely monitor and see live view from multiple GV-DVR / NVR / VMS, GV-Recording Server and GV-IP Devices.
GV-Failover Server	GV-Failover Server is a video backup server that enables you to automate recording backups upon the failed recording of GV-Recording Server.
GV-GIS	GeoVision Geographic Information System is designed for vehicle tracking and location verification.
GV-Multi View	GeoVision multi-channel viewing software that allows you to view up to 36 channels through the network.
GV-Redundant Server	GV-Redundant Server is a video backup server. It keeps an extra copy of your recordings from GV-Recording Server.
GV-Remote ViewLog	GeoVision viewing software that allows you to play back recorded files remotely.
GV-DVR / NVR	GeoVision Analog and Digital Video Recording Software. The GV-DVR / NVR also refers to Multicam System, GV-NVR System and GV-Hybrid DVR System at the same time.
GV-VMS	GeoVision video management system that records up to 64 channels of GeoVision and/or third-party IP devices.
GV-Video Gateway	GeoVision video streaming server is capable of receiving up to 256 channels from various IP video devices and distributing up to 600 channels to clients.
GV-Vital Sign Monitor	GeoVision Vital Sign Monitor is a central monitoring software that receives text alert upon events from multiple GV-DVR / NVR, GV-Recording Server and GV-IP Devices.

Chapter 1 Introduction

The GV-Recording Server is a video streaming server designed for large-scale video surveillance deployments. It can receive and record up to 256 channels from various IP video devices. Through an intuitive Web interface, each IP camera can be configured to record video continuously, upon motion detection, upon I/O trigger or according to a schedule.

In addition, it can simultaneously distribute up to 600 channels to its clients which include GV-DVR / NVR / VMS, GV-GIS (geographic information system), GV-Mobile Server, GV-Control Center (central monitoring system), Multi View (viewing software) and GV-Eye. GV-Recording Server can also send text notifications to one GV-VSM (Vital Sign Monitor) when alert conditions occur. Using the GV-Recording Server, the desired frame rates can be reached while the CPU loading and the bandwidth usage of IP video devices are significantly reduced.

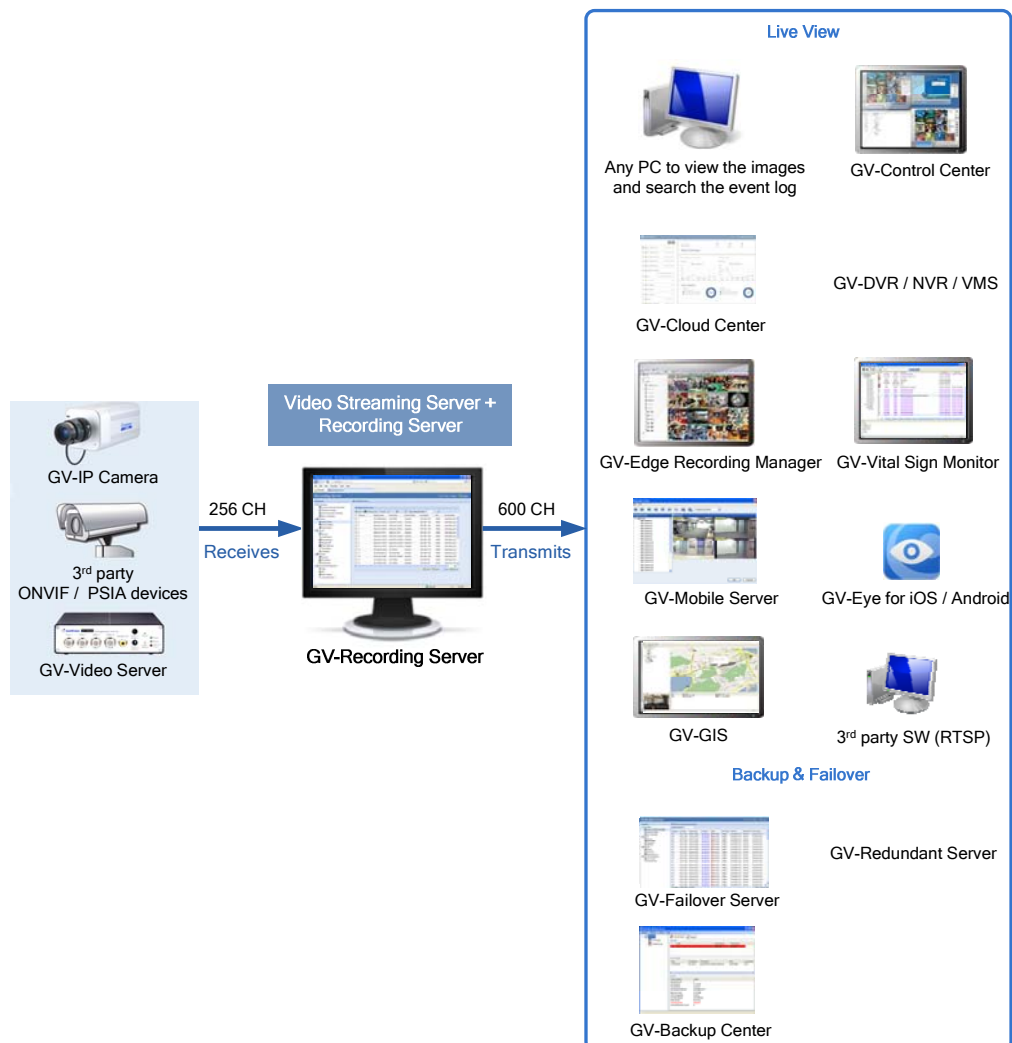
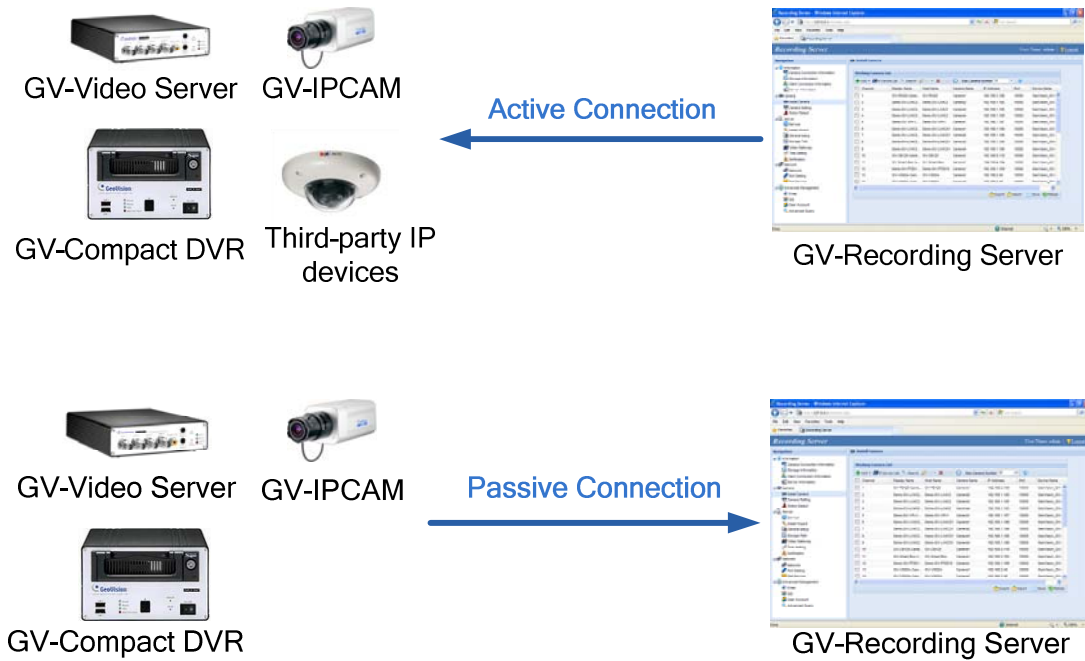

Figure 1-1

In some areas or countries, you may like to install 3G wireless Internet module (e.g. GPRS/UMTS) on the GV-Video Server or GV-Compact DVR but have a problem in obtaining a public IP address from the ISP. The **Passive** connection method of GV-Recording Server can solve the public IP issue by accepting the connection request from the GV-Video Server or GV-Compact DVR, and then distribute the video streaming to clients.



GV-Recording Server provides users with a secure and affordable remote backup solution with its support for GV-Backup Center, GV-Failover Server and GV-Redundant Server.

GV-Backup Center

GV-Backup Center can automatically store a copy of recordings at an offsite location. If a disaster strikes where the GV-Recording Server is located, the recording data remain safe at the backup site. A GV-Backup Center can only connect to one GV-Recording Server at a time. For connection setting, see *5.5.4 Backup Center*.

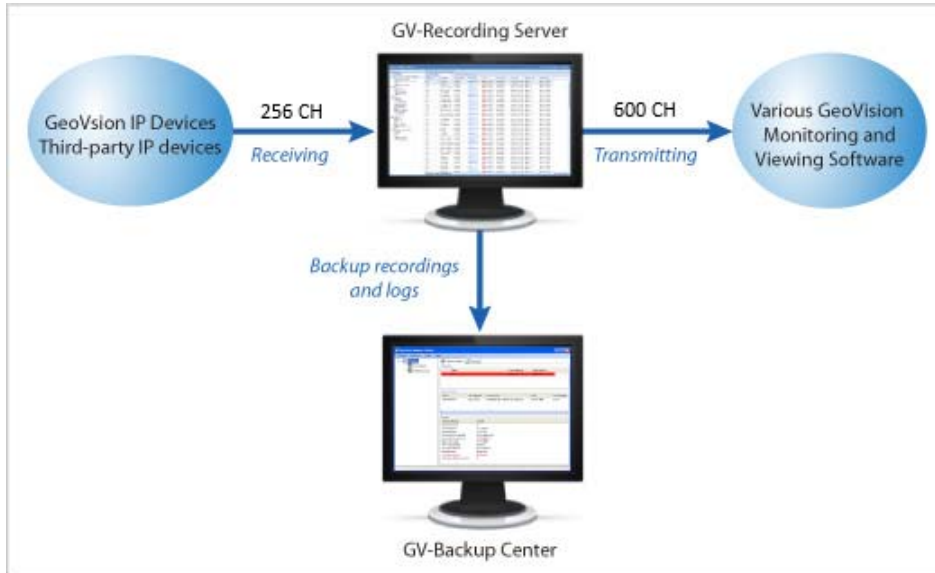

Figure 1-2

GV-Failover Server

GV-Failover Server is a video backup server that records up to 128 IP streams from the host GV-Recording Server when any of the following conditions occurs: (1) the host GV-Recording Server starts up without recording; (2) the file recycling fails; (3) there is an error in the hard drive; (4) there is a disconnection of IP cameras connected to the GV-Recording Server; (5) the host GV-Recording Server fails to operate properly. GV-Failover Server currently does not support CH129~256 of GV-Recording Server. For connection setting, see *5.5.5 GV-Failover Server*.

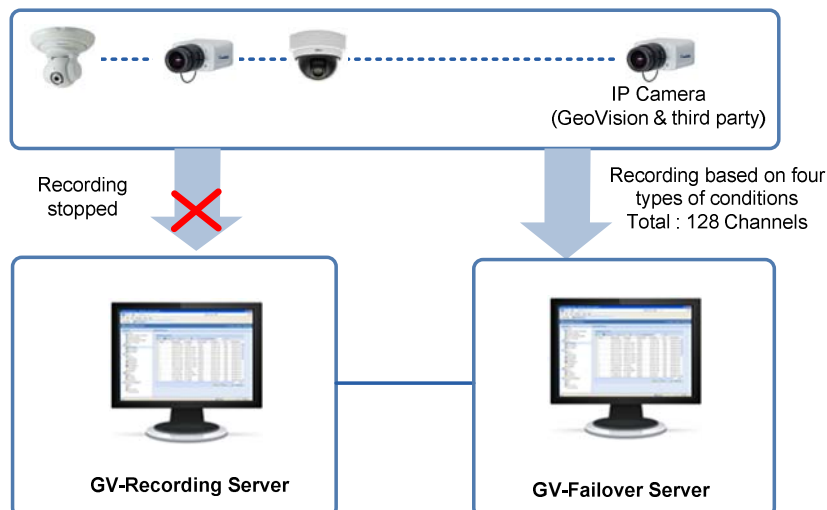

Figure 1-3

GV-Redundant Server

Similar to GV-Failover Server, GV-Redundant Server is also a video backup server. The main difference is that it keeps an extra copy of recordings from up to 128 IP channels connected to the GV-Recording Server. GV-Redundant Server currently does not support CH129~256 of GV-Recording Server For connection setting, see 5.5.5 *Failover Server*.

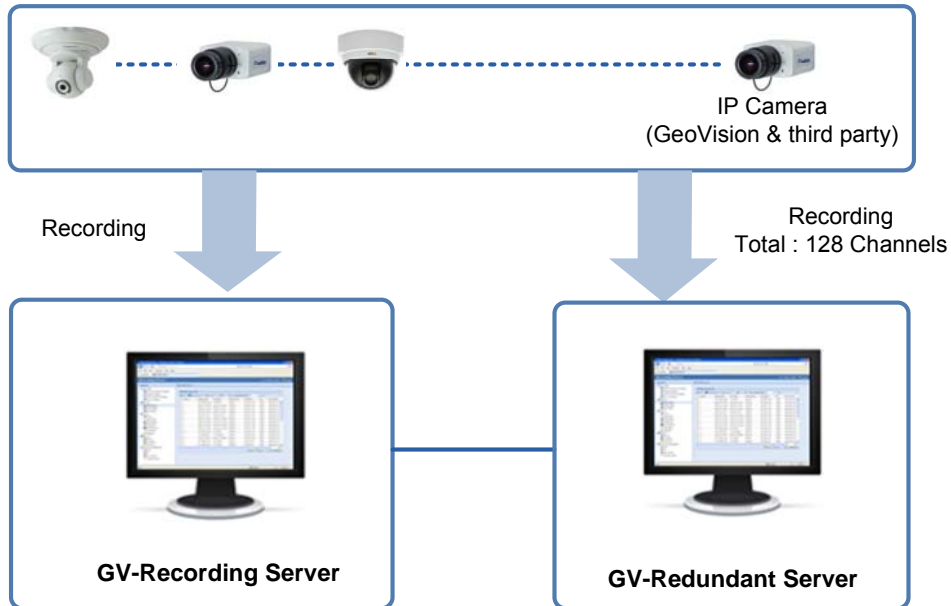

Figure 1-4

Note: Passive connection is currently not supported for GV-IP devices to GV-Failover / Redundant Server.

Features

- Simultaneously receiving and recording up to 256 IP channels
- Distributing of up to 600 IP channels to clients
- Video gateway between IP devices and receiving clients (GV-DVR / NVR / VMS, GV-Control Center, GV-GIS, GV-Mobile Server, Multi View, GV-Edge Recording Manager and GV-Eye)
- Support for third-party IP video devices (such as Sony, Axis, VIVOTEK, Panasonic, HikVision, Arecont Vision)
- Support for ONVIF, PSIA and RTSP protocols
- Different recording policies for each channel to record continuously, upon motion detection, upon I/O trigger or by schedule (recording upon I/O trigger are only for GV-IP devices)
- Video playback using Remote ViewLog
- Web interface to remotely configure and monitor GV-Recording Server using Internet Explorer, Firefox, Google Chrome and Safari
- Passive and active connection methods with IP video devices (passive connection only for up to 128 channels and is only supported by GV-IP devices)
- Solution for Mobile DVR (GV-Video Server, GV-Compact DVR) to obtain a public IP address
- Bandwidth monitoring
- Two-way audio communication (only for GV-IP devices through active connection)
- Remote event monitoring through GV-Vital Sign Monitor
- Remote backup through GV-Backup Center, GV-Failover Server and/or GV-Redundant Server
- IP device monitoring, event search and remote playback through GV-Cloud Center
- Smart streaming
- Support for live streaming of GV-IP cameras on YouTube
- Support for 31 languages

1.1 System Requirements

The following is system requirements to run the GV-Recording Server.

1.1.1 Minimum System Requirements

The PC used to install GV-Recording Server must meet the following minimum system requirements:

OS		64-bit Windows 7 / 8 / 8.1 / 10 / Server 2008 R2 / Server 2012 R2
CPU		Core i7 8700, 3.2 GHz
Memory		<ul style="list-style-type: none"> GV-Video Gateway: 6 GB Dual Channels GV-Recording Server: 16 GB Dual Channels
Hard Disk	Installation	1 GB
	OS	32 GB
Browser		<ul style="list-style-type: none"> Internet Explorer 8 to 11 Firefox 26.0 Google Chrome 31.0.1650.63 Safari 5.1.7
LAN		Gigabit Ethernet x 1~6
Software		.Net Framework 3.5
Hardware		<ul style="list-style-type: none"> GV-Video Gateway: Internal or external GV-USB Dongle GV-Recording Server: Internal GV-USB Dongle

Note:

1. The 1 GB hard disk requirement is for installation of GV-Recording Server only. To see hard disk requirements for recording, see [1.1.4 Recommended Hard Disk Requirements](#) for more details.
 2. The browsers supported by GV-Recording Server are Internet Explorer, Firefox, Google Chrome, and Safari. You can access single live view by using Firefox and Internet Explorer. Only Internet Explorer is supported for playing back recorded files.
 3. To see how to install the internal GV-USB Dongle, refer to [Appendix C. Install the Internal USB Dongle](#).
-

1.1.2 GV-USB Dongle

It is required to insert the GV-USB Dongle to the server for the GV-Recording Server software to be enabled. The GV-USB Dongle supports connection for up to 256 IP channels. You can select a dongle with GV-Video Gateway functions only or a GV-Recording Server dongle to access all functions.

GV-Video Gateway dongle supports both third-party IP devices and GV-IP devices, and comes in two types, internal and external dongles. For GV-Recording Server, you can select an internal dongle to enable GV-IP video devices only or a dongle to include both third-party IP devices and GV-IP devices.

GV-Video Gateway Only (without recording functions):

Free License	N/A
Max. License	256 channels
Increment for Each License	Third-party IP devices (Includes GV-IP video devices): 128, 256 IP channels
Optional Combinations	N/A
Dongle Type	Internal or external

GV-Recording Server (full functions available):

Free License	N/A
Max. License	256 channels
Increment for Each License	<ol style="list-style-type: none"> GV-IP video devices only: 8, 16, 32, 36, 40, 44, 48, 52, 56, 60, 64, 68, 72, 76, 80, 84, 88, 92, 96, 100, 104, 108, 112, 116, 120, 124, 128, 132, 136, 140, 144, 148, 152, 156, 160, 164, 168, 172, 176, 180, 184, 188, 192, 196, 200, 204, 208, 212, 216, 220, 224, 228, 232, 236, 240, 244, 248, 252, 256 IP channels. Third-party IP devices (Includes GV-IP video devices): 8, 16, 32, 36, 40, 44, 48, 52, 56, 60, 64, 68, 72, 76, 80, 84, 88, 92, 96, 100, 104, 108, 112, 116, 120, 124, 128, 132, 136, 140, 144, 148, 152, 156, 160, 164, 168, 172, 176, 180, 184, 188, 192, 196, 200, 204, 208, 212, 216, 220, 224, 228, 232, 236, 240, 244, 248, 252, 256 IP channels.
Optional Combinations	N/A
Dongle Type	Internal

Note: The internal GV-USB dongle can provide the Hardware Watchdog function to the GV-Recording Server by restarting the computer when Windows crashes. To install the internal GV-USB Dongle, refer to *Appendix C. Install the Internal USB Dongle*.

1.1.3 Compatible Versions of GeoVision Applications

The GV-Recording Server is only compatible with the following version:

- **GV-Backup Center:** version 1.1.2 or later
- **GV-Cloud Center:** version 1.0 or later
- **GV-Control Center:** version 3.7.0 or later (V3.6.0 or earlier only support 128 CH)
- **GV-DVR / NVR, Multi View, Multicast:** version 8.5.6 or later (for 64 CH)
- **GV-Edge Recording Manager for Windows:** version 2.0 (V1.0.0 or earlier only support 128 CH)
- **GV-Edge Recording Manager for Mac:** version 1.2.0 (V1.0.0 or earlier only support 128 CH)
- **GV-Eye:** version 2.7.4 or later (V2.7.3 or earlier only support 128 CH)
- **GV-GIS:** version 3.1.1 or later
- **GV-Mobile Server:** version 1.3 or later (for 64 CH)
- **GV-Redundant Server and Failover Server:** version 2.0 *[coming soon]* (V1.1.0.0 or earlier only support 128 CH)
- **GV-Vital Sign Monitor:** version 8.5.9 or later (for 128 CH)
- **GV-VMS:** version 14.10 or later (for 64 CH)

Note: The GV-Recording Server cannot be installed on the same PC as GV-DVR / NVR / VMS.

1.1.4 Recommended Hard Disk Requirements

The maximum channels per hard disk for motion recording and the recommended hard disk requirements for 24 hours of round-the-clock recording are listed as below.

Res.	Bitrate	FPS	Codec	Max. CH per HDD and required HDD size	Required HDD size (recording 256 CH, 24 hr)	Recommended HDD requirements
1.3 MP	0.83 Mbps	30 fps	H.265	32 CH / 280 GB	2.3 TB	1 TB 7200 RPM HDD x 8
2 MP	1.6 Mbps			32 CH / 540 GB	4.4 TB	
3 MP	2 Mbps			32 CH / 693 GB	5.6 TB	
4 MP	2.21 Mbps			22 CH / 747 GB	9 TB	1 TB 7200 RPM HDD x 12
5 MP	2.41 Mbps	22 CH / 814 GB		9.8 TB		
8 MP	3.5 Mbps	20 fps		22 CH / 1190 GB	14.3 TB	

Note:

1. The number of hard drives required varies depending on the write speed of the hard drive and the hard disk size required varies depending on the recorded file size. The recommended hard disk requirement is just for your reference.
2. For system efficiency, we recommend the **enterprise-level** hard disk drives with **7200 RPM** at least and average R/W speed above **110 MB/s**. Avoid using desktop-level hard disks which may affect system efficiency.
3. The hard disk requirements above are applicable to GV-DVR / NVR / VMS and GV-IP Devices only.

1.1.5 Recommended Network Requirements

The server's transmitting capacity varies depending on the number of Gigabit connections. The number of Gigabit network cards required to receive 256 channels and transmit 600 channels are listed below according to the resolution of the source video.

Resolution	Bitrate	FPS	Codec	Gigabit Network Cards Required	
				Receiving 256 CH	Transmitting 600 CH
1.3 MP	0.83 Mbps	30 fps	H.265	Gigabit network card x 1 (up to 256 CH per card)	Gigabit network card x 1 (up to 600 CH per card)
2 MP	1.6 Mbps				Gigabit network card x 2 (up to 300 CH per card)
3 MP	2 Mbps				
4 MP	2.21 Mbps				
5 MP	2.41 Mbps	20 fps		Gigabit network card x 2 (up to 128 CH per card)	Gigabit network card x 3 (up to 200 CH per card)
8 MP	3.5 Mbps				

The deployment of Gigabit connections for transmitting and receiving is suggested as illustrated below. Ensure to run every Gigabit connection on a different network in order to reduce the lag on any network connection.

2 / 3 / 4 MP Source Video

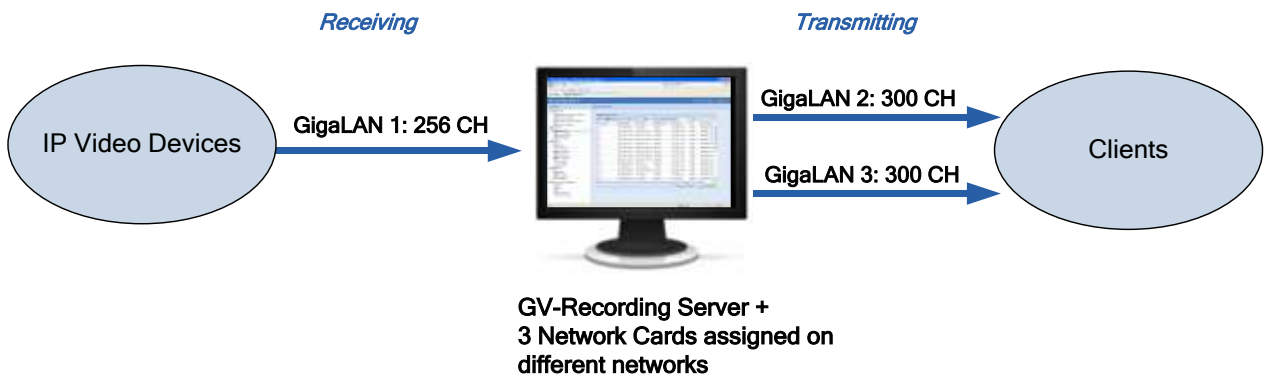

5 / 8 MP Source Video

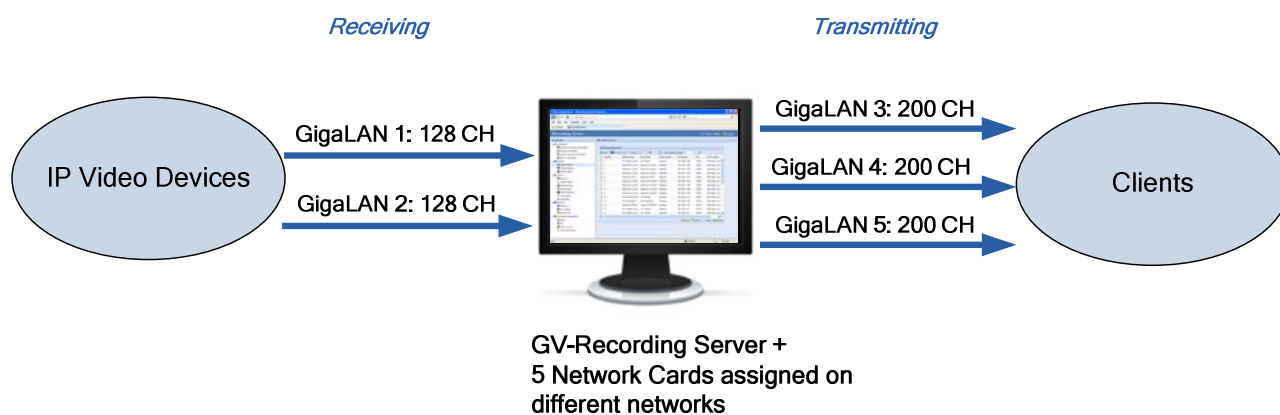
**Note:**

1. To avoid network bottleneck, each network card must be assigned a different IP address and subnet mask. Refer to *Appendix D. How to Avoid Network Bottleneck* for details.
2. The network requirements above are applicable to GV-DVR / NVR / VMS and GV-IP Devices only.

1.1.6 Requirements for Connecting to GV-Backup Center

When GV-Recording Server is connected with GV-Backup Center, the recordings of all the channels connected to GV-Recording Server will be backed up. Before you establish the connection, note the following:

- To back up the recordings of all 256 channels from 1 unit of GV-Recording Server, the GV-Backup Center must be installed with at least 6 hard disks.
- Each GV-Backup Center can only connect to one GV-Recording Server at a time.



For details on connecting GV-Backup Center, see *5.5.4 GV-Backup Center*.

Chapter 2 Installation

2.1 Installing GV-Recording Server

It is recommended to install the GV-Recording Server on a dedicated computer or server. Before installing GV-Recording Server, you need to plug the **GV-USB Dongle** to the computer, and then install the **dongle driver** and **Microsoft .Net Framework**.

You can install the driver and the GV-Recording Server from [GeoVision website](#).

1. To install USB driver, select **Driver, FW, Patch** from the drop-down list and click the **Download** icon  of **GV-Series Card Driver / GV-USB Devices Driver**.
2. To install GV-Recording Server, select **Primary Applications** from the drop-down list and click the **Download** icon  of **GV-Recording Server / GV-Video Gateway**.

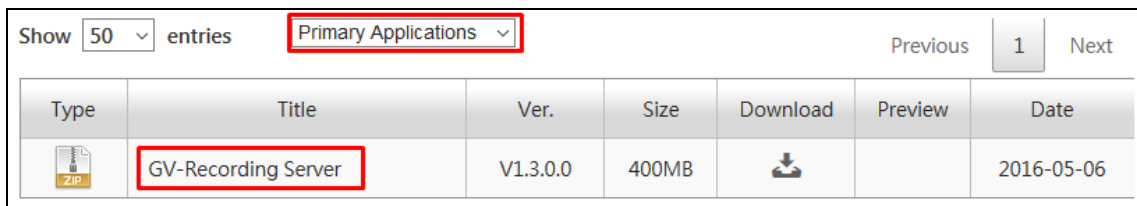



Type	Title	Ver.	Size	Download	Preview	Date
	GV-Recording Server	V1.3.0.0	400MB			2016-05-06

Figure 2-1

3. To download and install .Net Framework 3.5, go to: <http://www.microsoft.com/en-us/download/details.aspx?id=21>.

Note: If you are using Window 8 or Windows Server 2012, see *How to install .Net Framework 3.5 for Windows Server 2012 and Windows 8* in Appendix F before proceeding to the next step.

2.2 Starting GV-Recording Server

After installing GV-Recording Server, you are prompted to define an ID and password, with the password requiring to be at least 8 characters long and containing at least 3 of the following types of characters: uppercase letters, lowercase letters, numbers and special characters.

Once set, the GV-Recording Server icon  appears in the system tray. Follow the steps below to access the Web interface of GV-Recording Server.

1. The default HTTP port is 80 and the command port is 20000. To customize the port number, right-click the GV-Recording Server icon and select **Configure**.

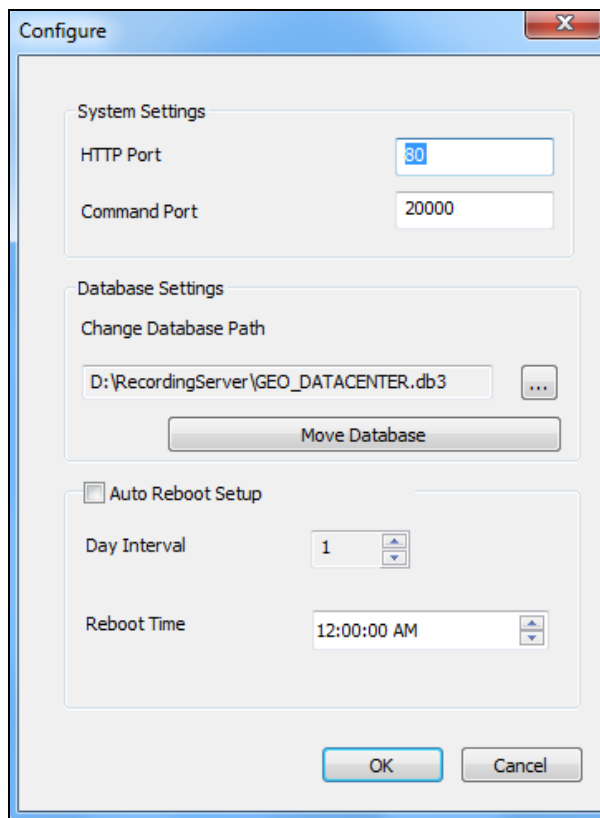

Figure 2-2

2. To enable the automatic reboot of the GV-Recording Server and Windows, select **Auto Reboot Setup** and specify the **Day Interval** between each reboot as well as the **Reboot Time** for automatic reboot.
3. Right-click the GV-Recording Server icon and select **Start Service**.

4. After the GV-Recording Server icon turns green, right-click the icon again and select **Access Web Interface**. The Web interface login page appears.

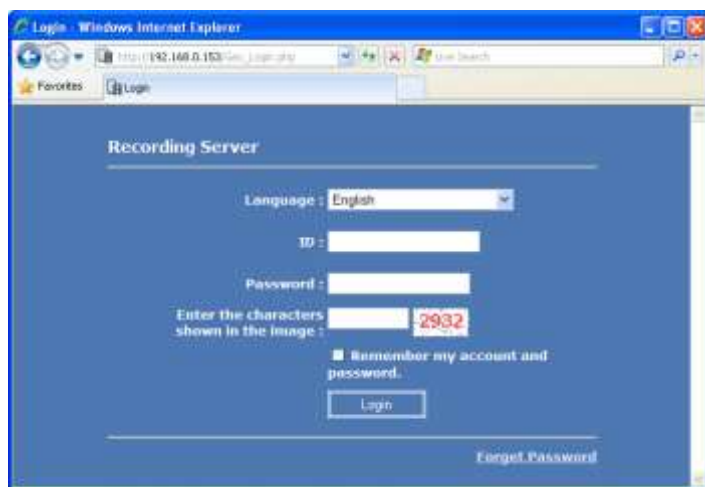

Figure 2-3

5. Type the same **ID** and **Password** used to login.
6. Type the verification number shown in the image.
7. Click **Login**. The GV-Recording Server Web interface is now displayed.

To access the Web interface from a remote computer, start the Internet browser and type the IP address or the domain name of the GV-Recording Server in the Location/Address field. If the default HTTP port has been changed, type a colon and the port number after the IP address, for example, **Http://192.168.3.199:81/**. After the login page appears, follow steps 6 to 8 above to log in the Web interface.

Note:

1. To enable the updating of images in Microsoft Internet Explorer, you must set your browser to allow ActiveX Controls and perform a one-time installation of GeoVision's ActiveX component onto your computer.
2. If the GV-Recording Server is installed behind a firewall or router, you may need to open these default ports: HTTP port 80, server connection port (Active connection port) 11000 and Passive connection port 50000, remote playback (Remote ViewLog) port 5552.
3. The Command port is used for running the recording server. By default, 20 ports are reserved, ranging from 20000 to 20019, for the program use. If another program is using any of the default ports, a port conflict may occur.

IMPORTANT:

If users do not note down the login ID or set up the mail server and an e-mail to retrieve the password, they will need to reinstall Windows operating system once the ID or password is lost. Refer to [5.4.3 Mail Service](#) and [5.5.9 User Account](#) to see related settings respectively.

The GV-Recording Server icon in the system tray also allows you to change the database storage path, back up settings and restore settings.

1. To change the location of the database path, right-click the GV-Recording Server icon to select **Configure**, select a new location and click **Move Database**.
2. To back up settings, right-click the GV-Recording Server icon and select **Backup Settings**. Select to back up **Basic**, **Host List**, **E-Map** and/or **Password** settings and click **OK**.
3. To restore settings, right-click the GV-Recording Server icon and select **Restore Settings**. Select the backed-up file and click **OK** to begin restoring settings.

Note: You can only access the **Configure** and **Restore Settings** button when GV-Recording Server service is stopped. To stop service, you will be required to log in using the Administrator account.

Chapter 3 Getting Started

When logging in the GV-Recording Server for the first time, you will be prompted with the Install Wizard to help you add IP video devices, assign a storage path to store the recordings and commence connecting.

Note: To start the Install Wizard manually, click **Install Wizard** under **Server** in the left menu.

To add IP video devices:

1. When the Install Wizard is launched, the GV-Recording Server automatically detects available IP video devices under the LAN. This dialog box appears.

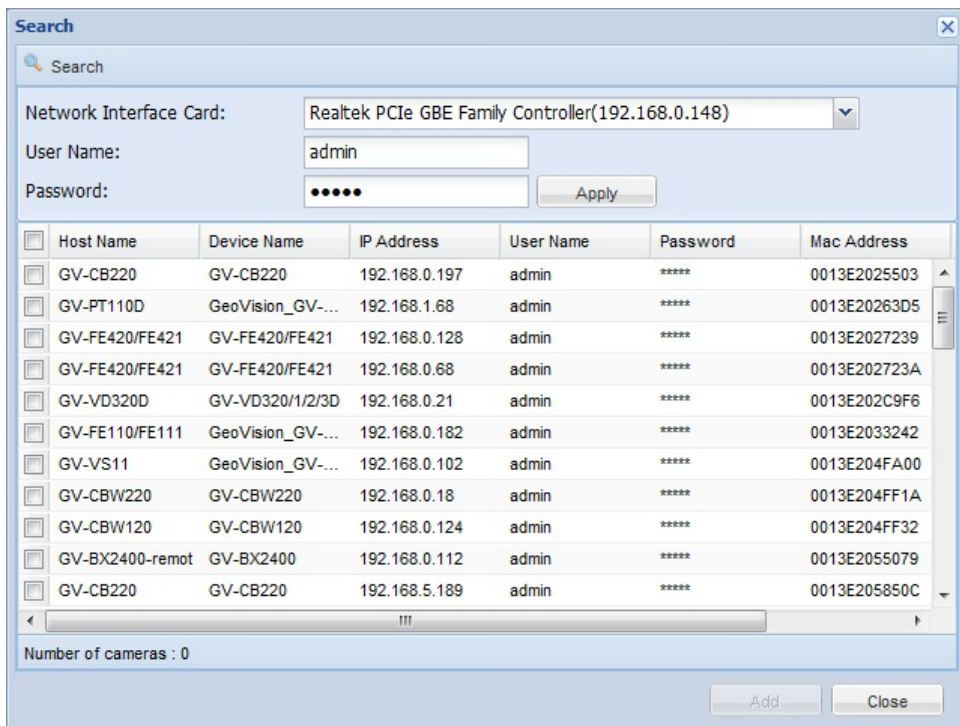

Figure 3-1

2. If you have multiple network interface cards, use the drop-down list to select one and click **Search** to re-detect IP devices using the specified network card.
3. Select the IP video devices you want to connect to.

- Click **Add** and map the device to a channel. The Working Camera List appears.

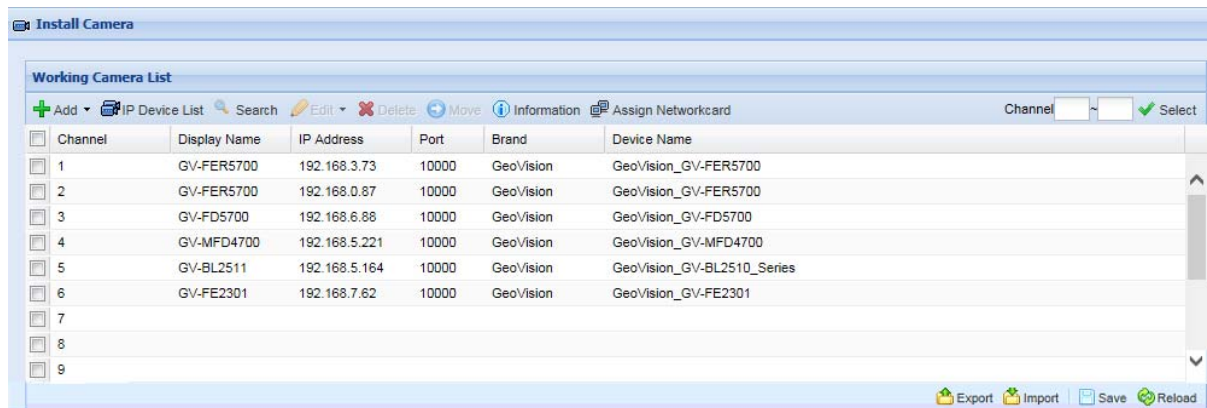



Figure 3-2

- The GV-Recording Server will try to connect to the devices using **admin** as the default ID and password. To connect with other ID and password, select the camera, click **Edit**  and select **Host Setting**. In the dialog box, select **Change ID and Password**, type the ID and password of the camera and click **OK**.
- Click **Save** and click **Next Page**.

Note: IP cameras that are yet to have passwords set can only be added manually, see [To add cameras by manually typing the camera's information, 5.2.1 Install Camera](#).

To assign storage paths:

- Click **Auto** or **Manual** when a message appears asking you to select the storage dispatch mode. If you click **Manual**, skip to step 4.
- Select at least one storage path to store camera recordings and click **OK**. In this case, Local Disk (D:\) and (E:\) are selected to be the storage locations.

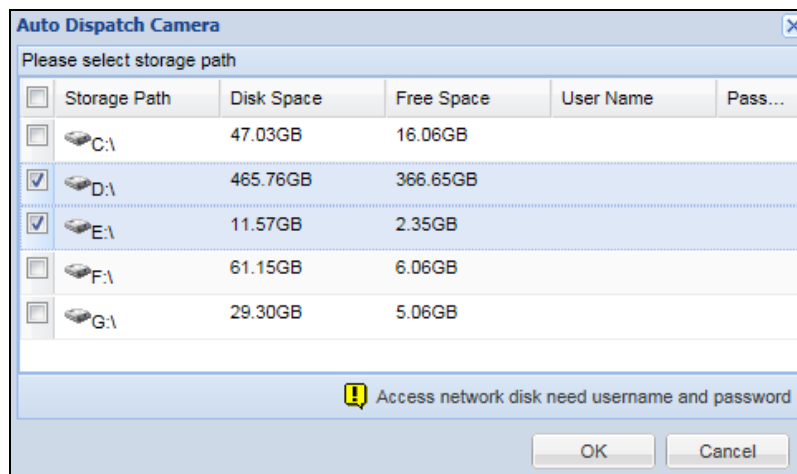

Figure 3-3

- Click either storage folder to see the cameras in the *Working Camera List* being equally distributed between **Storage1** (Disk D:\) and **Storage2** (Disk E:\).

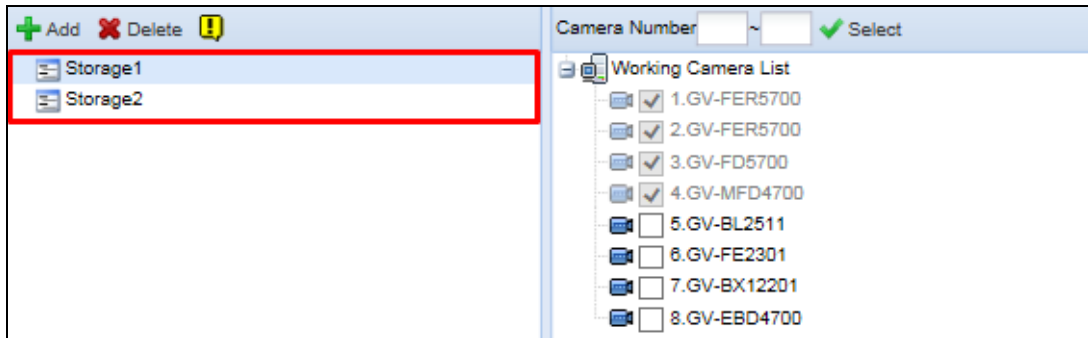



Figure 3-4

- To add a new storage folder in a different disk drive, click **Add**  or select an existing storage folder.

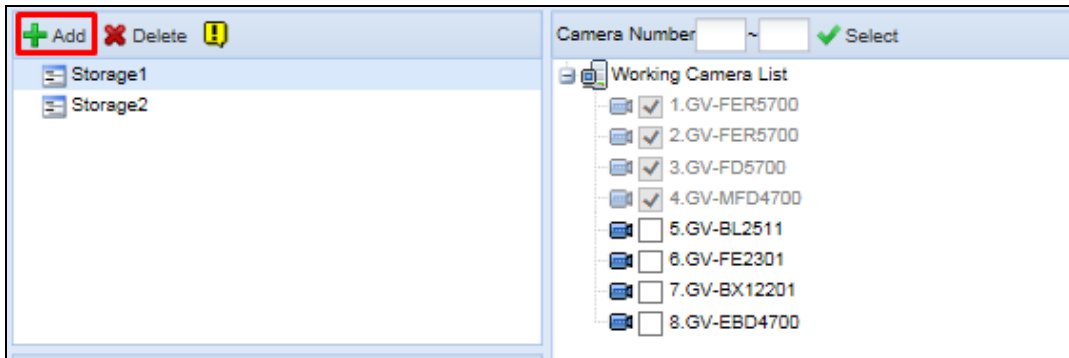

Figure 3-5

- Use the default storage path, or click the **Add** button to select a new storage path.

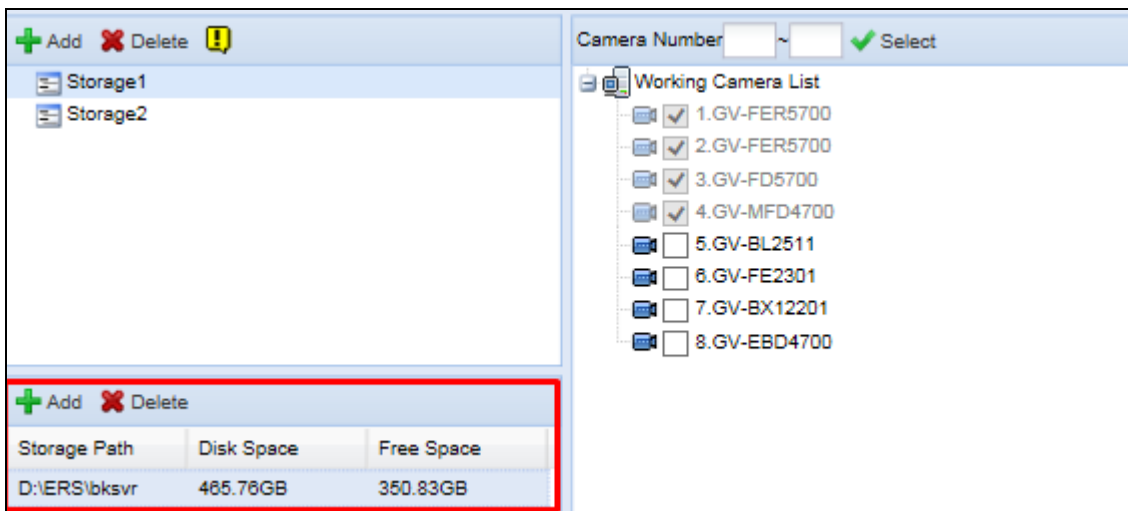

Figure 3-6

- Under *Working Camera List*, select the cameras you wish to assign to the current storage path or type a range of camera number and click the **Select** button. Videos of the cameras selected will be recorded to the storage path indicated.

- To specify a recycle threshold, select **Yes** next to **Recycle** and type a minimum free space. When the remaining free space falls below that threshold, the oldest files will be overwritten.

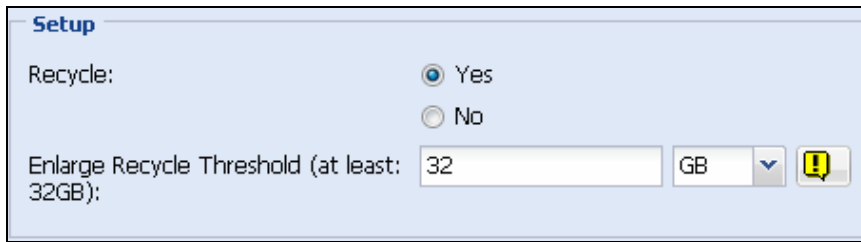



Figure 3-7

- If you want to automatically re-assign the cameras, click **Auto Dispatch** .
- Click **Save** and click **Next Page** at the lower-right corner of the page.

IMPORTANT:

- For details on the maximum channels per hard disk for motion recording and the recommended hard disk requirements for 24 hours of round-the-clock recording, see [1.1.4 Recommended Hard Disk Requirements](#).
- When multiple hard disks are added to a storage group, recycling of the oldest files will begin when the remaining free space of all hard disks in the storage group fall below the recycle threshold.
- You can also select a network drive as storage path, e.g. the drive from an iSCSI or a NAS system.

To start service:

- In the **Service** page, to be able to receive and record IP channels, select **Start** for Recording Server.
- To enable the Video Gateway to transmit video to clients, select **Start** for Video Gateway.

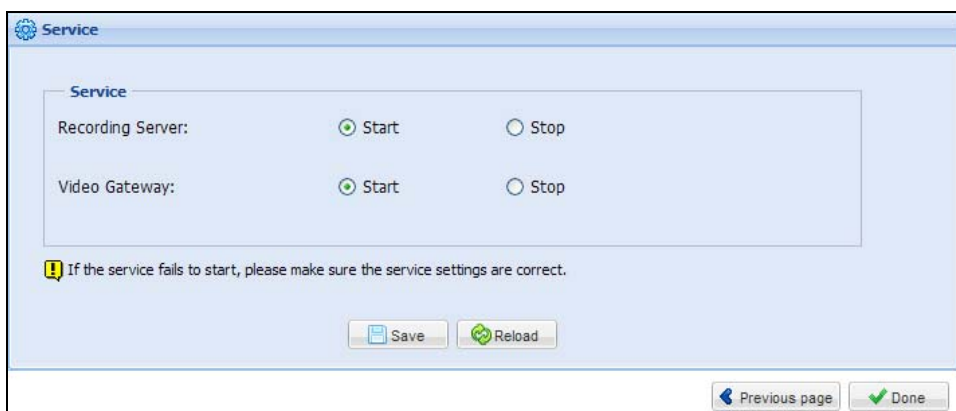

Figure 3-8

- Click **Save** and click **Done**. The Camera Connection Information page appears and shows the connection status of the camera added.

Note:

1. The default recording policy is round-the-clock recording.
 2. When the GV-USB Dongle for only GV-Video Gateway is inserted, the Recording Server option and recording functions will not be available.
-

After adding camera, you can refer to *5.2.2 Camera Setting* to see how to start or stop recording individual cameras. In addition, you can customize camera settings such as setting video attributes, recording policy and recording schedule.

Chapter 4 Active and Passive Mode

The GV-Recording Server is a proxy server on a network that can receive and record up to 256 IP video channels as well as transmit up to 600 IP video channels to clients simultaneously. There are two ways to establish connection with IP video devices: **active connection**, where GV-Recording Server initiates the connection, and **passive connection**, where the GV-IP video device initiates the connection.

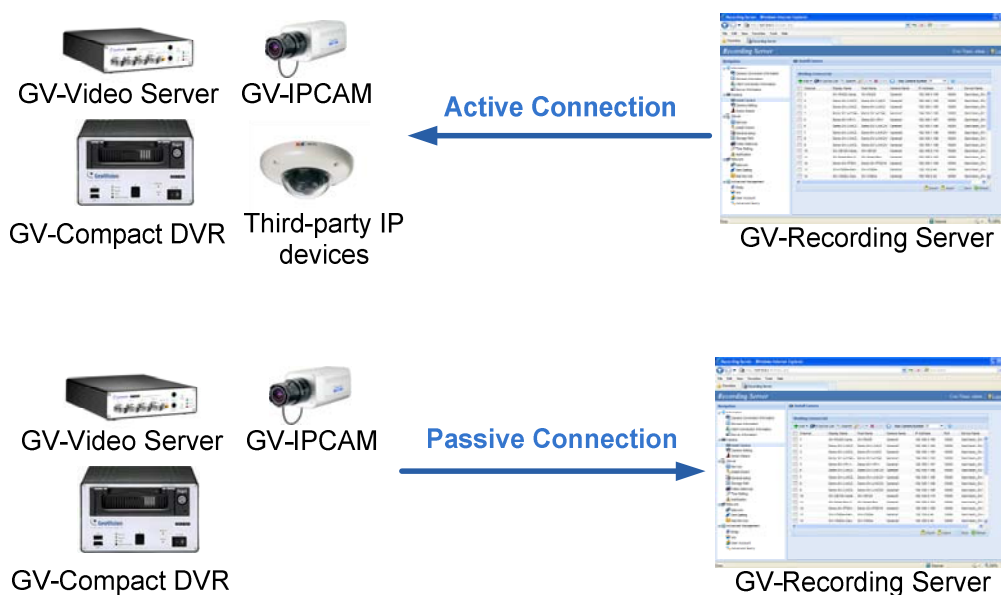

Figure 4-1

Note: Passive connection only supports up to 128 channels and is only supported for GV-IP devices.

4.1 Active Connection

There are multiple ways to actively connect to IP video devices from GV-Recording Server. You can refer to *Chapter 3 Getting Started* and simply follow the steps in Installation Wizard to actively add IP video devices. For other ways to actively add IP video devices or to customize camera settings, refer to *5.2.1 Install Camera* and *5.2.2 Camera Setting*.

4.2 Passive Connection

To create passive connection, the GV-Recording Server must be configured to allow connections from GV-IP Devices. Passive connection to GV-Recording Server is only supported for GV-IP Devices.

To allow passive connection on GV-Recording Server:

1. In the left menu, select **General Setup** under **Server**.
2. Select **Allow Geo IP Device Login**. The default ID and Password for passive connection to the GV-Recording Server is **admin**, and the default port value is **50000**. If you change the ID and Password, they must be matched on the Web interface of the GV-IP Device (See Figure 4-3).

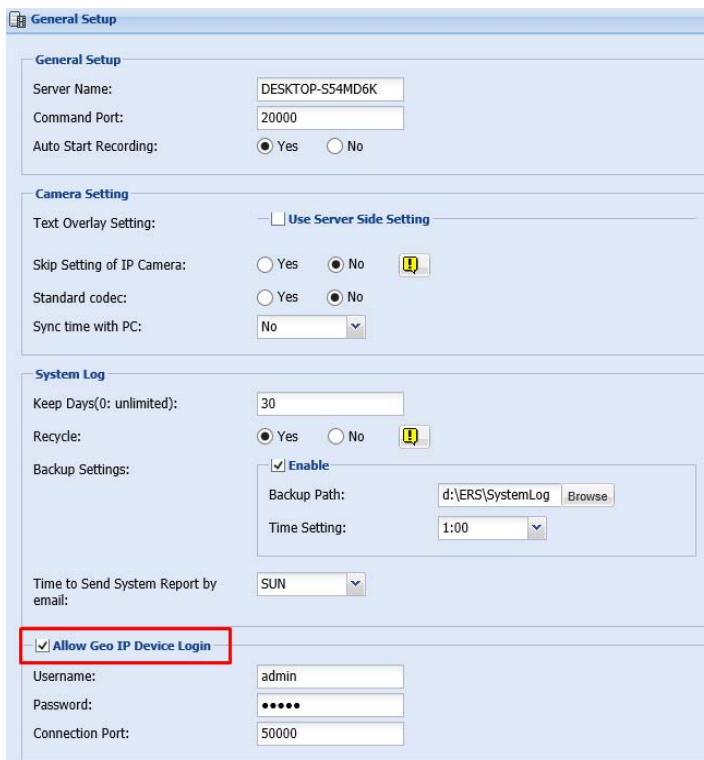

The screenshot shows the 'General Setup' configuration page. The 'Allow Geo IP Device Login' checkbox is checked and highlighted with a red box. Below it, the Username is set to 'admin', the Password is masked with dots, and the Connection Port is set to '50000'. Other settings include Server Name (DESKTOP-S54MD6K), Command Port (20000), Auto Start Recording (Yes), Camera Setting (Use Server Side Setting), Skip Setting of IP Camera (No), Standard codec (No), Sync time with PC (No), System Log (Keep Days: 30, Recycle: Yes, Backup Settings: Enable, Backup Path: d:\ERS\SystemLog, Time Setting: 1:00), and Time to Send System Report by email (SUN).

Figure 4-2

3. Click **Save**.

To access GV-Recording Server on GV-IP Devices:

The GV-IP Device must also be configured to access the GV-Recording Server.

1. Access the **Video Gateway / Recording Server** setting page on the Web interface of the GV-IP Device.

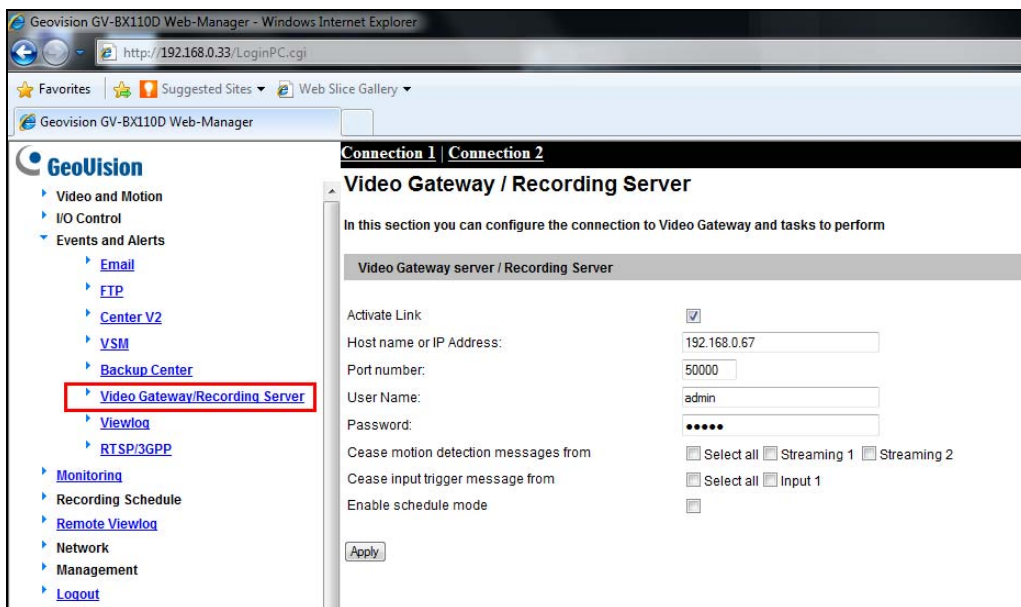

Figure 4-3

2. Select **Activate Link**.
3. Type the IP address or domain name of the GV-Recording Server.
4. Keep the default port number of **50000** or modify it to match the connection port configured on GV-Recording Server’s General Setup page (Figure 4-2).
5. Type the **User Name** and **Password** of the GV-Recording Server to log in. The default values for both login username and password are **admin**.
6. Click **Apply** to connect. When the connection is established, the following message will be displayed at the bottom of the Web interface.

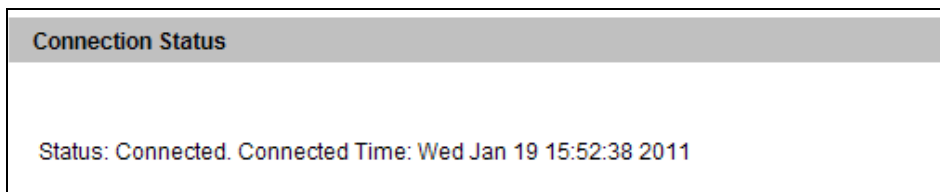

Figure 4-4

To start passive connection on GV-Recording Server:

1. On the GV-Recording Server, select **Install Camera** in the left menu. This dialog box appears.

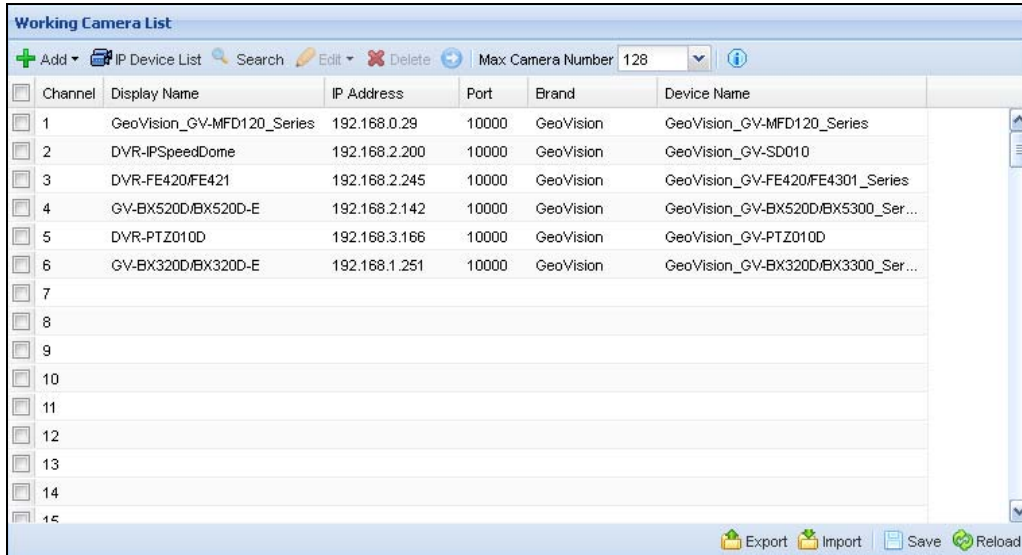



Figure 4-5

2. Click **IP Device List**  on the Working Camera List. The passive connection is listed as **Passive Mode** under **Connection Type**.

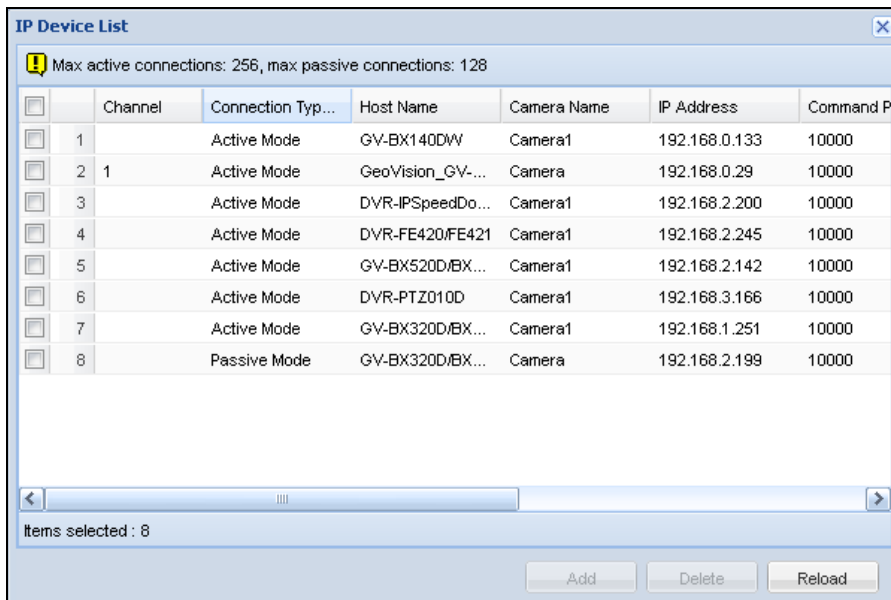

Figure 4-6

3. Click **Add** and select a channel. The IP device will be added to the Working Camera List.
4. Click **Save**.
5. In the left menu, click **Service** and select **Start** to enable the Recording Server and Video Gateway services.
6. Click **Save** to start services.

Chapter 5 Administrator Mode

The Administrator has access to all configurations in GV-Recording Server. On the left side of the Web interface, five categories of configurations are listed in a tree menu: **Information**, **Camera**, **Server**, **Network** and **Advanced Management**.

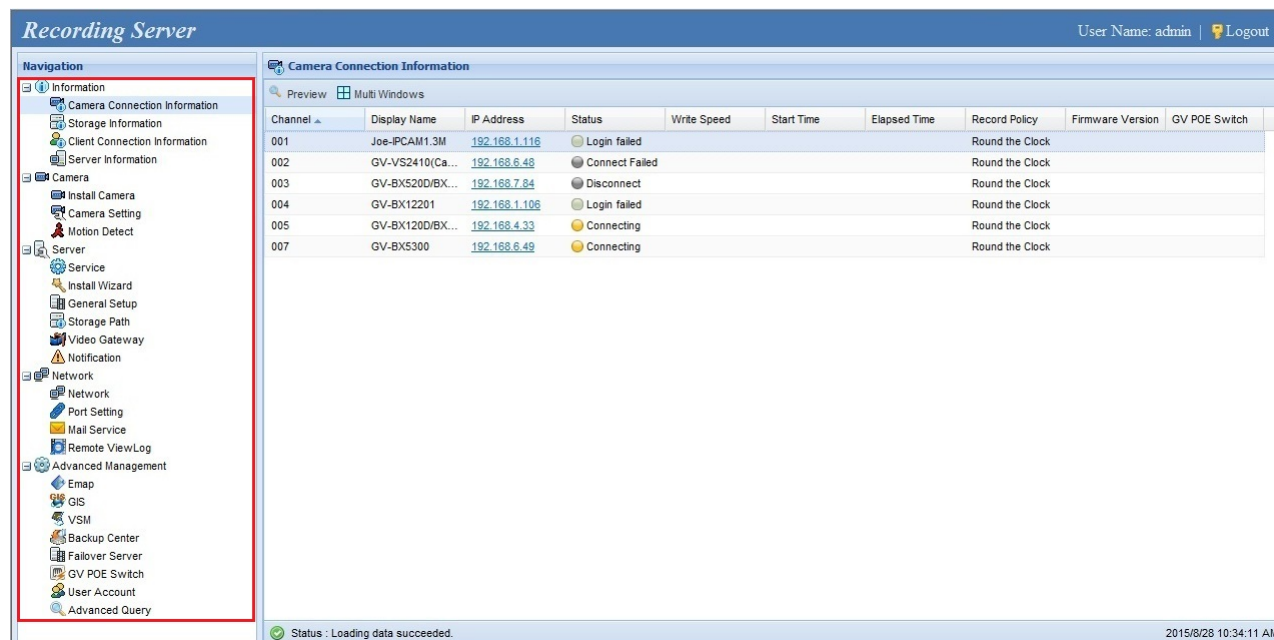

Figure 5-1

List of Menu Options

Find the topic of interest by referring to the sections below.

5.1 Information	<ul style="list-style-type: none"> 5.1.1 Camera Connection Information 5.1.2 Storage Information 5.1.3 Client Connection Information 5.1.4 Server Information
5.2 Camera	<ul style="list-style-type: none"> 5.2.1 Install Camera 5.2.2 Camera Setting 5.2.3 Motion Detect
5.3 Server	<ul style="list-style-type: none"> 5.3.1 Service 5.3.2 Install Wizard 5.3.3 General Setup 5.3.4 Storage Path 5.3.5 Video Gateway 5.3.6 Notification
5.4 Network	<ul style="list-style-type: none"> 5.4.1 Network 5.4.2 Port Setting 5.4.3 Mail Service 5.4.4 Remote ViewLog 5.4.5 SNMP
5.5 Advanced Management	<ul style="list-style-type: none"> 5.5.1 Emap 5.5.2 GIS 5.5.3 VSM 5.5.4 Backup Center 5.5.5 Failover Server 5.5.6 GV-PoE Switch 5.5.7 GV-Cloud Center 5.5.8 Live Streaming Sharing 5.5.9 User Account 5.5.10 Advanced Query

5.1 Information

This section introduces how to look up camera connection information, storage information, client connection information and server information.

5.1.1 Camera Connection Information

The Camera Connection Information page shows the connection status of all IP devices added to the **Working Camera List** and allows you to watch their live view.

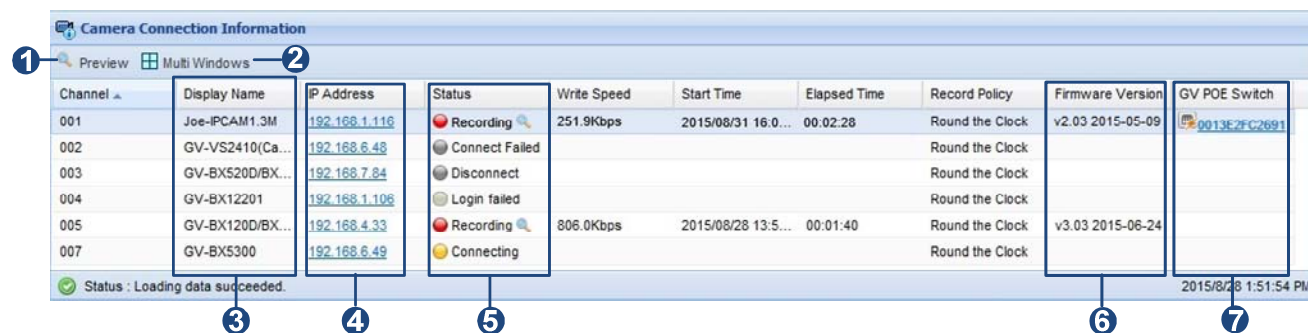

Figure 5-2

The controls in the window:

No.	Name	Description
1	Preview	Shows the live view of the selected camera.
2	Multi Windows	Shows the live view of multiple cameras in the list.
3	Display Name	The device will be identified by the display name when accessed by clients.
4	IP Address	Click to access the Web interface of the camera.
5	Status	<ul style="list-style-type: none"> Recording : The camera is recording. Click to access the live view. Connected : The camera is connected. Click to access the live view. Connecting : Connecting to the camera. Connect Failed : Unable to connect to the camera. Disconnect : Service has been stopped. VIDEO LOST : Unable to obtain video from the device. Login failed : Incorrect ID or password. Recording Failure : Unable to record video.
6	Firmware Version	Shows the Firmware version of the camera.
7	GV-PoE Switch	Click to access the Connect Setting and the status information of the GV-PoE Switch used, when applicable.

Note: The display of the Firmware version is only supported for GeoVision cameras that are connected to GV-Recording Server by active connection.

To watch the live view:

1. To watch the live view of an individual camera, select a connected camera and click the **Preview** button or the  icon. The live view, video codec, resolution and the frame rate of the camera are displayed.



Figure 5-3

2. To watch the live view of multiple cameras, click the **Multi Windows** button. This window appears.

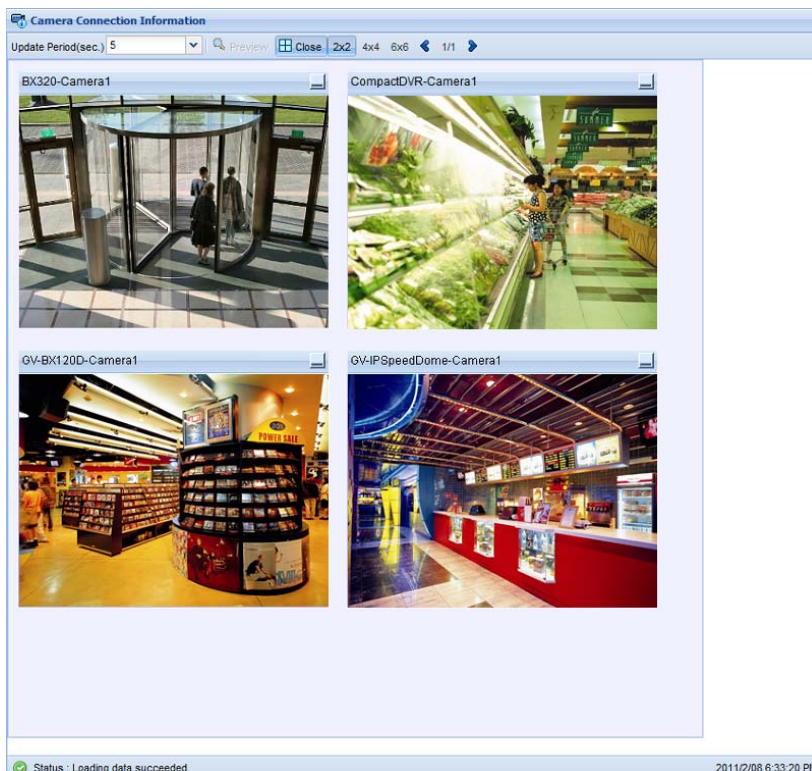



Figure 5-4

3. To specify the number of camera live view per page, click the **2x2** or **4x4** button.
4. Use the left and right arrows   to switch between pages.

5.1.2 Storage Information

The Storage Information page shows the storage paths designated to store recorded videos. For each storage path, you can see the disk's used size, free space, write speed and the time when the disk became full.

Disk Name	Disk Type	Storage Path	Used Size	Free Space	Write Speed	Power on hour	Health Status	Disk Full Time
Storage Group: Storage1								
C	Local Disk	C:\ERS\bksvr	13.3GB	452.5GB	18.0Mbps	197days2Hour		2015/01/09 03:01

Figure 5-5

You can click the **Health Status** button to monitor hard disk reliability. The numeric information can be used to identify possible system failures and fix bugs in GV-Recording Server.

S.M.A.R.T - Disk Name : C					
Name	Current Value	Worst	Threshold	Data	
Power on hour	94	94	0	197days2Hour	
Temperature	106	66	0	41	
Reallocate sector count	200	200	140	0	
Spin retry count	100	100	0	0	
Reallocation event count	200	200	0	0	
Current pending sector count	200	200	0	0	
Uncorrectable sector count	100	253	0	0	

S.M.A.R.T | 2015/1/06 3:12:32 PM

Reload

Figure 5-6

5.1.3 Client Connection Information

The Client Connection Information page shows the clients currently logged into the GV-Recording Server. The platform type, IP address, camera number, stream number, bandwidth occupied, FPS and login time of each client are listed.

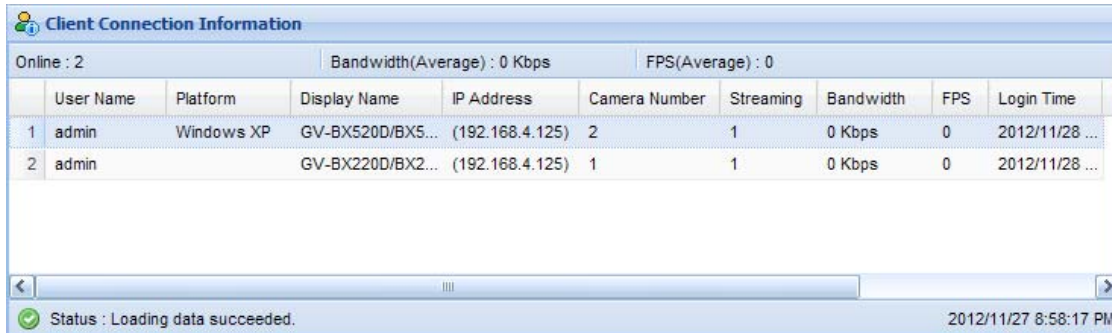

The screenshot shows a web interface titled "Client Connection Information". At the top, it displays "Online : 2", "Bandwidth(Average) : 0 Kbps", and "FPS(Average) : 0". Below this is a table with the following data:

	User Name	Platform	Display Name	IP Address	Camera Number	Streaming	Bandwidth	FPS	Login Time
1	admin	Windows XP	GV-BX520D/BX5...	(192.168.4.125)	2	1	0 Kbps	0	2012/11/28 ...
2	admin		GV-BX220D/BX2...	(192.168.4.125)	1	1	0 Kbps	0	2012/11/28 ...

At the bottom of the interface, a status bar shows "Status : Loading data succeeded." and the timestamp "2012/11/27 8:58:17 PM".

Figure 5-7

5.1.4 Server Information

The Server Information page shows server information such as version information, CPU loading, transfer speed of network interface card and service status.

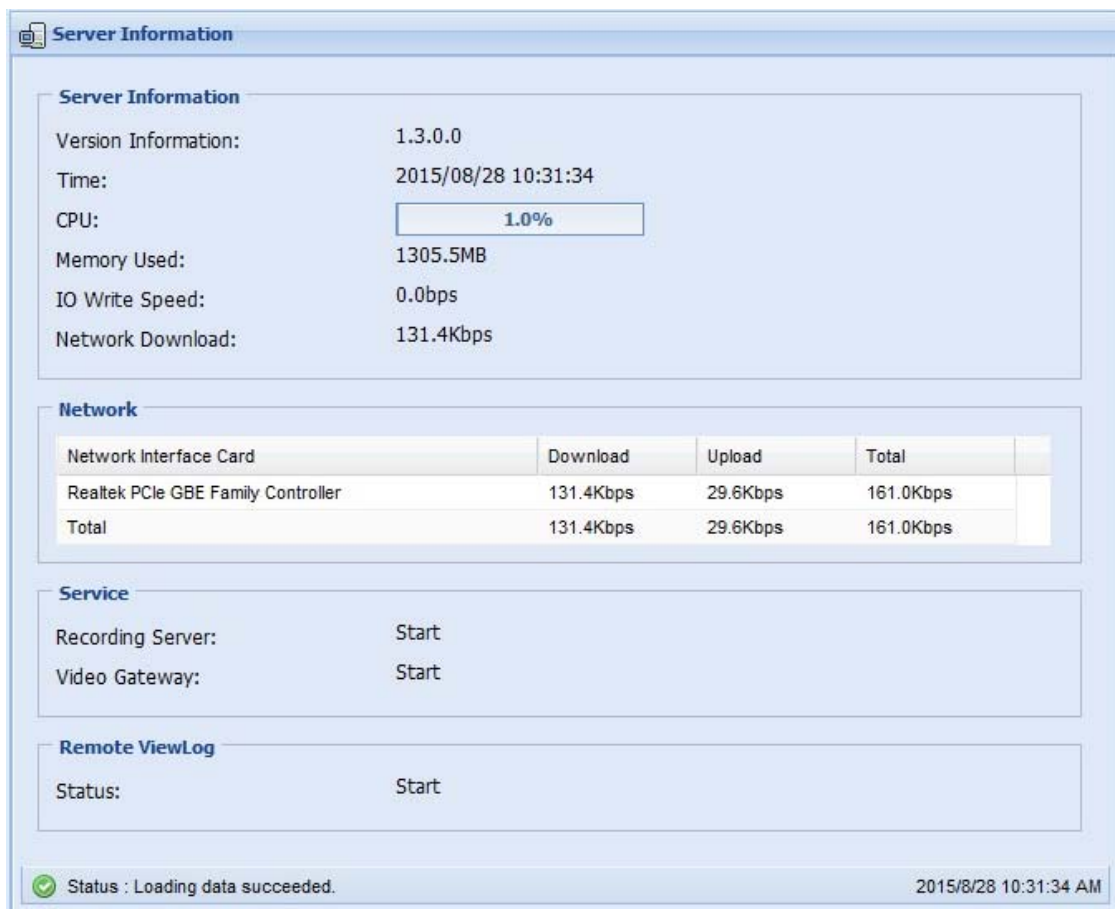

The screenshot shows a web interface titled "Server Information". It is divided into several sections:

- Server Information:**
 - Version Information: 1.3.0.0
 - Time: 2015/08/28 10:31:34
 - CPU: 1.0% (shown in a progress bar)
 - Memory Used: 1305.5MB
 - IO Write Speed: 0.0bps
 - Network Download: 131.4Kbps
- Network:**

Network Interface Card	Download	Upload	Total
Realtek PCIe GBE Family Controller	131.4Kbps	29.6Kbps	161.0Kbps
Total	131.4Kbps	29.6Kbps	161.0Kbps
- Service:**
 - Recording Server: Start
 - Video Gateway: Start
- Remote ViewLog:**
 - Status: Start

At the bottom, a status bar shows "Status : Loading data succeeded." and the timestamp "2015/8/28 10:31:34 AM".

Figure 5-8

5.2 Camera

The Camera section allows you to add camera, configure camera settings and set up motion detection.

5.2.1 Install Camera

The Install Camera page helps you add IP devices to the *Working Camera List*.

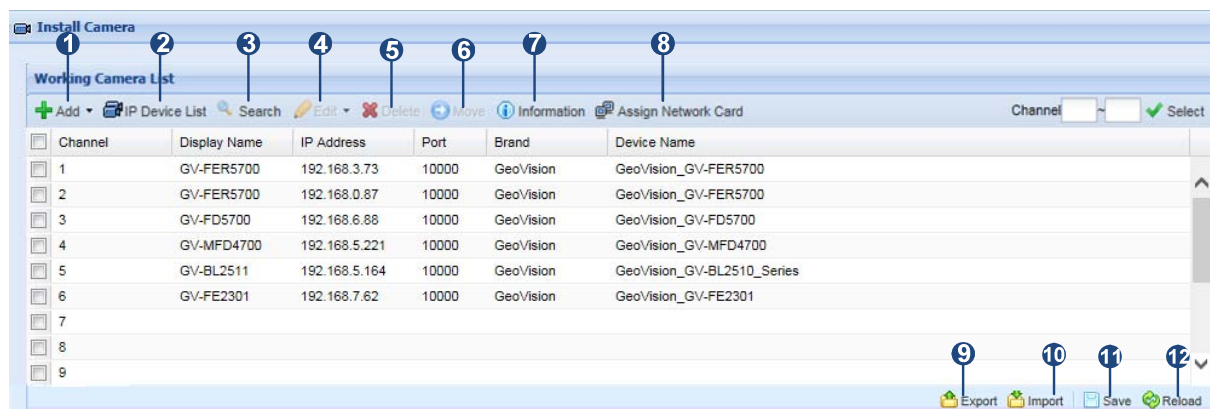

Figure 5-9

The controls in the window:

No.	Name	Description
1	Add	Add camera by manually typing the camera's connection information or by selecting from IP Device List.
2	IP Device List	Shows connection information of cameras that were and are being connected through active and/or passive mode. You can select the listed camera(s) to be added to <i>Working Camera List</i> or delete them from the IP Device List.
3	Search	Searches for available IP devices in the LAN.
4	Edit	Select a camera and click Edit to change its host settings or display name.
5	Delete	Select camera(s) and click Delete to delete them from <i>Working Camera List</i> .
6	Move	Select a camera and click Move to move it to another channel.
7	Information	Shows the number of GV-IP Devices and third-party cameras supported by the current GV-Dongle license.
8	Assign Network Card	Select camera(s) to be assigned to a network card within Network Interface Card drop-down list.
9	Export	Exports the camera connection information to a .hlt file.

No.	Name	Description
10	Import	Imports camera connection information by using a previously-exported .hlt file.
11	Save	Saves the current settings.
11	Reload	Reloads the page.

There are three ways to add cameras to the Working Camera List:

To add cameras using the Search function:

1. Click the **Search** button.
2. In the dialog box, select a network interface card if you have more than one and click the **Search** button again. IP devices in the LAN will be detected.

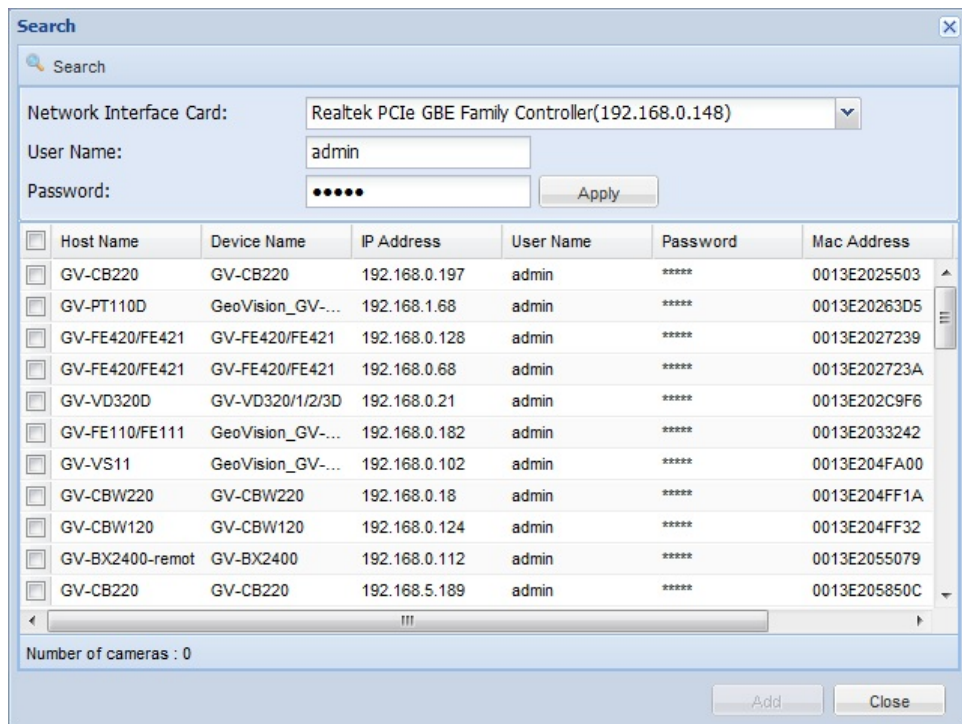

Figure 5-10

Note:

1. When adding devices through the **Search** function, the User Name and Password of the device will be set to **admin** by default. To change the ID and Password, go to the **Install Camera** page, select the camera and click the **Edit** button. Select **Host Setting** and select **Change ID and Password**. Type the correct ID and Password and click **OK**.
2. IP cameras that are yet to have passwords set can only be added manually, see *To add cameras by manually typing the camera's information below*.

3. Select the desired IP devices and click **Add** to add them to the Working Camera List.

To add cameras using the IP Device List:

1. Click the **IP Device List**. The cameras that were and are being connected are all listed.
2. Select the desired IP device(s).
3. Click **Add**.

To add cameras by manually typing the camera’s information:

1. Click the **Add** button and select **Add New Host**. This dialog box appears.

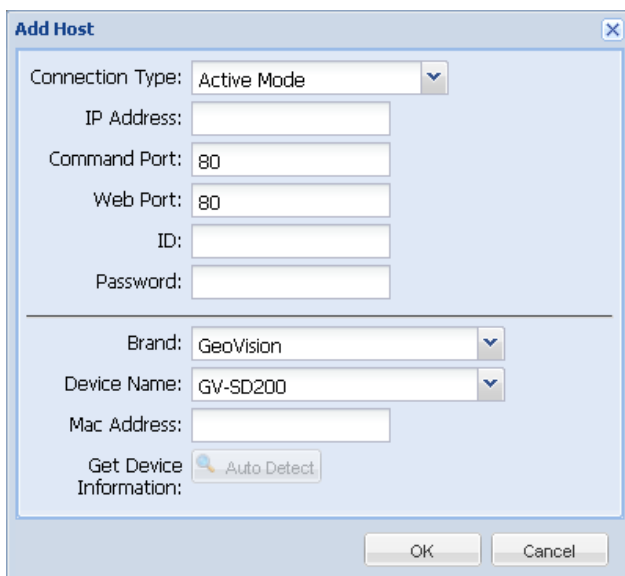

Figure 5-11

2. Select a **Connection Type** and type the **IP Address**, **ID** and **Password** of the IP device.
3. Change the default **Command Port** and **Web Port** if needed.
4. Click **Auto Detect** to detect the camera’s **Brand**, **Device Name** and **Mac Address**.
 - A. For IP cameras that are yet to have passwords set, an Add New Account dialog box appears, where users can set a login ID and Password for the IP cameras.



Figure 5-12

Note: This function is supported by GV-IP cameras, such as GV-ABL / ADR / AVD / EBD / TBL / TDR / TVD series and SD2722-IR / 3732-IR.

5. If the device information cannot be automatically detected, manually use the drop-down list to select the **Brand** and **Device Name** and type the **Mac Address** of the device.
6. If you want to use ONVIF, PSIA or RTSP protocol for connecting, select **Protocol** from the **Brand** drop-down list and select the desired protocol under **Device Name**.

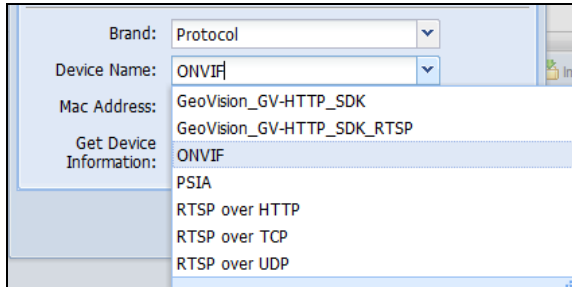

Figure 5-13

7. Click **OK**.

After adding the cameras through one of the methods above, a dialog box appears. Type a number and the cameras will be mapped to that channel and the channels after it.

Merge and Replace

If the channels are already occupied, a message appears to ask if you want to replace existing cameras. Click **Yes** and a message appears to ask if you want to replace or merge the recordings of existing camera with the new camera for playback.

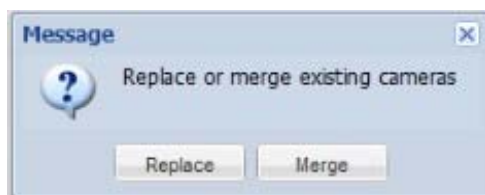

Figure 5-14

If you click **merge**, you will see the video events from both the existing camera and the new camera in Remote ViewLog player. See figure 5-15, as an example, in which GV-BX2600 is the pre-existing camera and GV-FE420 is a newly added camera. If you click **replace**, you will only see the video events from the new camera in Remote ViewLog player. See figure 5-16 as an example.

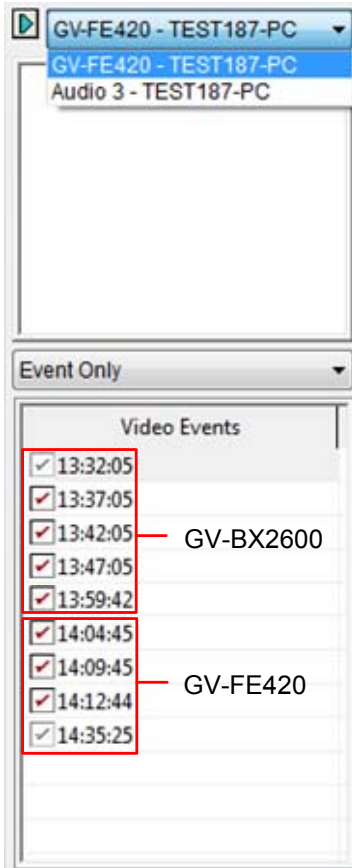

Figure 5-15

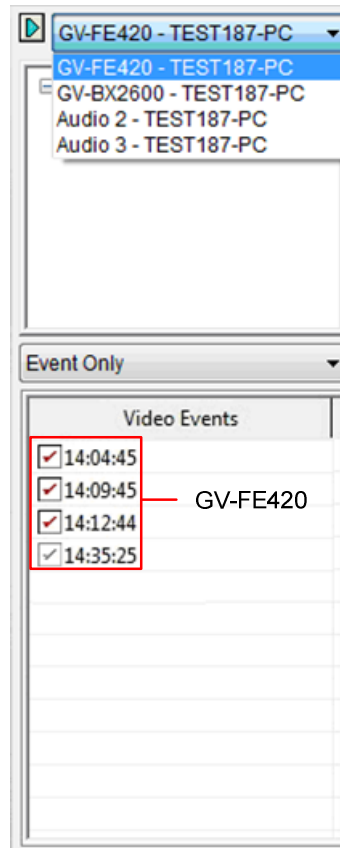

Figure 5-16

5.2.2 Camera Setting

In the Camera Setting page, you can customize the video settings, recording policy and recording schedule of the cameras. In the Working Camera List, double-click a camera or select the desired camera and click the **Edit** button to access its settings.

Options in the Working Camera List

- **Recording:** Select / clear the selection to start or stop recording from the camera.



Working Camera List					
 Edit		 Information			
Chan...	IP Address	Display Name	Mac Address	Device Name	<input type="checkbox"/> Recording
1	192.168.3.48	GV-ADR4701	0013e2f775ac	GeoVision_GV-ADR4701	<input checked="" type="checkbox"/>
2	192.168.6.116	GV-AVD4710	0013e2f7d408	GeoVision_GV-AVD4710	<input checked="" type="checkbox"/>
3	192.168.51.144	GV-FER5701	0013e2ff3683	GeoVision_GV-FER5701	<input checked="" type="checkbox"/>
5	192.168.7.132	GV-EBD8700	0013e22401d6	GeoVision_GV-EBD8700	<input checked="" type="checkbox"/>
6	192.168.158.246	GV-EBD2702	0013e2f77512	GeoVision_GV-EBD2702	<input checked="" type="checkbox"/>
7	192.168.0.33	GV-EFD5101	0013e2ff1f54	GeoVision_GV-EFD5101	<input checked="" type="checkbox"/>
8	192.168.0.18	GV-QSD5730	0013e2242b09	GeoVision_GV-QSD5730	<input checked="" type="checkbox"/>
9	192.168.72.253	GV-SD2722-IR	0013e2fa1424	GeoVision_GV-SD2722-IR	<input checked="" type="checkbox"/>
11	192.168.7.60	GV-TVD4700	0013e224018e	GeoVision_GV-TVD4700	<input checked="" type="checkbox"/>
12	192.168.0.14	GV-VD8700	0013e2fa05f4	GeoVision_GV-VD8700	<input checked="" type="checkbox"/>
128	192.168.0.30	GV-BX2700-FD	0013e21aaaae3	GeoVision_GV-BX2700_FD	<input checked="" type="checkbox"/>
129	192.168.7.246	GV-TBL8710	0013e21c413e	GeoVision_GV-TBL8710	<input checked="" type="checkbox"/>

Figure 5-17

5.2.2.A Video Settings

Select the **Video** tab to access the camera's video attributes and audio settings.

The screenshot displays the 'Camera Setting' window with the 'Video' tab selected. The interface is divided into three main sections: Preview, Video, and Audio.

Preview Section:

- Display Name: GV-BX4700
- IP Address: 192.168.5.25
- Brightness: Slider set to 51
- Contrast: Slider set to 106
- Saturation: Slider set to 103
- Hue: Slider set to 0
- Buttons: Default, Reload
- Warning: If you are unable to connect, please first make sure Video Gateway is open.
- Preview Image: A live video feed showing a laboratory or office environment.

Video Section:

- Connection Type: Active Mode (Warning icon)
- Streaming: Streaming(1), Streaming(2)
- Enable: Yes No
- Apply this setting to all cameras.
- Ratio: 16:9
- Video Codec: H265
- Resolution: 2560x1440
- Bandwidth Control:
 - VBR: Quality: 0, Maximum Bitrate: false
 - CBR: Maximum Bitrate: false
 - Smart Streaming:
 - Static Scene: Quality: false, Maximum Bitrate: false
 - Dynamic Scene: Quality: false, Maximum Bitrate: false
- Bitrate Reduction: Range: (36 ~ 300). * The bigger the lower bitrate Level.
- Apply this setting to all cameras. (Warning icon)
- Button: Get Streaming Setting

Audio Section:

- Audio
- Two-way Audio

At the bottom right, there are buttons for Save and Return.

Figure 5-18

[Preview] Move the sliders to adjust the camera image's brightness, contrast, saturation and hue. Click the **Default** button to load the default settings of the camera's video attributes.

[Video]

- **Connection Type:** Displays the mode the camera is connected by: active or passive.
- **Streaming:** If the camera supports dual stream, you can select Stream 1 or Stream 2 to set up the ratio, video codec and resolution of the stream.
- **Enable:** You can choose to enable both streams or disable one of the streams.
- **Apply this setting to all cameras:** Apply enabling / disabling of Stream 1 and Stream 2 to all IP cameras in the *Working Camera List*.

- **Ratio:** Select a display ratio for the stream selected.
- **Video Codec:** Select a type of video compression method.
- **Resolution:** Select a resolution for live view and recorded video.
- **Bandwidth Control:** Select a bitrate mode to control the bitrate, which in turns allows the amount of bandwidth usage to be controlled.
 - ⊙ **VBR (Variable Bitrate):** The quality of the video stream is kept as constant as possible at the cost of a varying bitrate. The bandwidth is much more efficiently used than a comparable CBR. Set the image quality to one of the 5 standards: **Standard, Fair, Good, Great and Excellent**.
Maximum Bitrate: When the system bitrate exceeds the value, the system will automatically lower its bitrate so as not to exceed it. Select a bitrate from the drop-down list.
 - ⊙ **CBR:** CBR is used to achieve a specific bitrate by varying the quality of the stream. The bitrates available for selection depend on the image resolution.
 - ⊙ **Smart Streaming:** When the mode is selected, the bitrates will be automatically reduced in static scenes, significantly maximizing bandwidth and lowering file size.
You can choose the image quality of Static Scene and Dynamic Scene to one of the 5 standards: **Standard, Fair, Good, Great and Excellent**. You can even choose the maximum bitrate to optimize the bandwidth.
Bitrate Reduction Level: The bigger the value the more bitrates can be reduced in static scenes, thus saving the bandwidth and recording size.
- **Apply this setting to all cameras:** Apply the same streaming settings above, except for enabling / disabling Stream 1 and Stream 2, to all IP cameras of the same model.
- **Update Streaming Setting:** Click to refresh and obtain the most up-to-date streaming settings from the camera.

[Audio]

- **Audio:** Enables audio of live view.
- **Two-Way Audio:** Enables two-way audio for the camera.

Note:

1. Two-way audio is only supported for GV-IP devices connected through active mode.
2. The camera setting options may vary depending on the camera model and/or firmware version.

5.2.2.B Record Setting

Select the **Record Setting** tab to customize the general setup, recording policy and I/O device setting for each IP device.

Camera Setting

Video **Record Settings** Schedule

General Setup

Apply this setting to all cameras.

Only Record Key Frame

Record GPS Data

Save Audio

Video Clip Time (1~5 min.):

Maximum FPS (1~30)

Keep Days(1~999)

Never Recycle

Sync recording from camera SD card when reconnected

Record preview stream

Recording:

Video Frame Rate Limit: Enable Economic Mode

I/O Device Setting

Rec. Video

Email Alarm

Recording Policy

Apply this setting to all cameras.

Recording Policy:

Post-Rec (1~5 Sec):

Pre-Rec (1~5 Sec):

Storage Path

Storage Path:

Save Return

Figure 5-19

[General Setup]

- **Apply this setting to all cameras:** Apply the General Setup settings to all cameras.
- **Only Record Key Frame:** Select to record key frames only.
- **Record GPS Data:** Records the video with GPS data.
- **Save Audio:** Include sounds when recording videos.
- **Video Clip Time (1~5 min.):** Specify the maximum time length of each recorded file. For example, if you set the Video Clip Time to be 5 minutes, a 20-minute video will be divided into four 5-minute clips.
- **Maximum FPS (1~30):** Limit the frame rate per second to the number specified. This option only applies to JPEG.
- **Keep Days (1~999):** Specify the number of days to keep the recorded files.
- **Never Recycle:** Select to never recycle videos recorded by this camera.
- **Sync recording from camera SD card when reconnected:** Enables restoring recordings from the camera's SD card when reconnecting to it after a temporary disconnection.

Note:

1. For this function to work, the cameras selected cannot be connected to more than one GV-Recording Server at a time.
 2. This function is only supported by ONVIF cameras of G conformant and the following models of GV-IP cameras:
 - GV-BL2702 series / 3700 / 4702 / 4713 / 5700 / 5713
 - GV-BX2700 series / 2700-FD / 4700 series / 4700-E / 4700-FD / 5700 series
 - GV-EBL4702 series / EBL4711 / EDR4700 series / EFD4700 series
 - GV-EFER3700 / EFER3700-W / FER5700 / FER5701
 - GV-MFD2700 series / MFD4700 series
 - GV-VD2702 / 2712 / 3700 / 4702 / 4711 / 4712 / 5700 / 5711
-

- **Record preview stream:** Select to record both Stream 1 and 2
- **Recording:** If the camera supports dual stream, you can select to use Stream 1 or 2 for recording. The other stream will be used for preview.
- **Video Frame Rate Limit:** You can choose to record in a lower frame rate or only the key frames for selected cameras using the Economic Mode to save recording space.
 - ⊙ **Enable Economic Mode:** Select this option to enable the Economic Mode.
 - ⊙ **JPEG:** Specify the number of frame rates per second to record in JPEG codec during motion and non-motion events.

- ⊙ **H264/H265:** Select to record in the maximum frame rate or record key frames only in H.264/265 codec during motion and non-motion events.

[I/O Device Setting] Use the drop-down list to select an input device. When the selected input device is triggered, recording will be triggered or an e-mail alert will be sent depending on the options configured below.

- **Rec. Video:** Start recording and save video clips in the time lengths specified above upon input trigger.
- **E-mail Alarm:** Send an e-mail alert to the recipient set upon input trigger. To use this function, you must also set up the mail server. See *5.4.3 Mail Service*.

[Record Policy] In the Record Policy section, use the **Record Policy** drop-down list to select one of the following record policies.

- **Round-the-Clock:** Records continuously.
- **Motion Detection:** Starts recording only upon motion detection.
- **I/O Trigger:** Starts recording upon input trigger.
- **Schedule:** Records according to the schedule specified.

Note:

1. Recording upon I/O trigger is only supported by GV-IP devices.
 2. When a camera is added to the Working Camera List, the default recording policy is Round-the-Clock.
-

To customize the recording policy:

1. The **Post-Rec** and **Pre-Rec** options are available when Motion Detection, I/O Trigger or Schedule is selected.
If **Motion Detection**, **I/O Trigger** or **Schedule** is selected, type a time period between 1 and 5 seconds in the **Pre-Rec** and **Post-Rec** fields to start and continue recording for the number of seconds specified before and after the trigger event and/or scheduled time.
2. For setting up **Schedule**, refer to *5.2.2.C Schedule*.
3. If **I/O Trigger** is selected, you need to set up the related settings in the **I/O Device Setting** above.
4. To apply the same Record Policy to all cameras in the Working Camera List, select **Apply this setting to all cameras**.

5. Click **Save**.

[Storage Path] Shows the designated storage path for videos recorded from the camera. To see how to assign storage path, refer to *Setting Storage Path, Chapter 3 Getting Started* for details.

5.2.2.C Schedule

In the **Schedule** tab, you can create a recording schedule by setting different recording policies during different time periods. First, create a daily recording schedule and then assign the daily schedule to a date or a day of the week in the calendar.

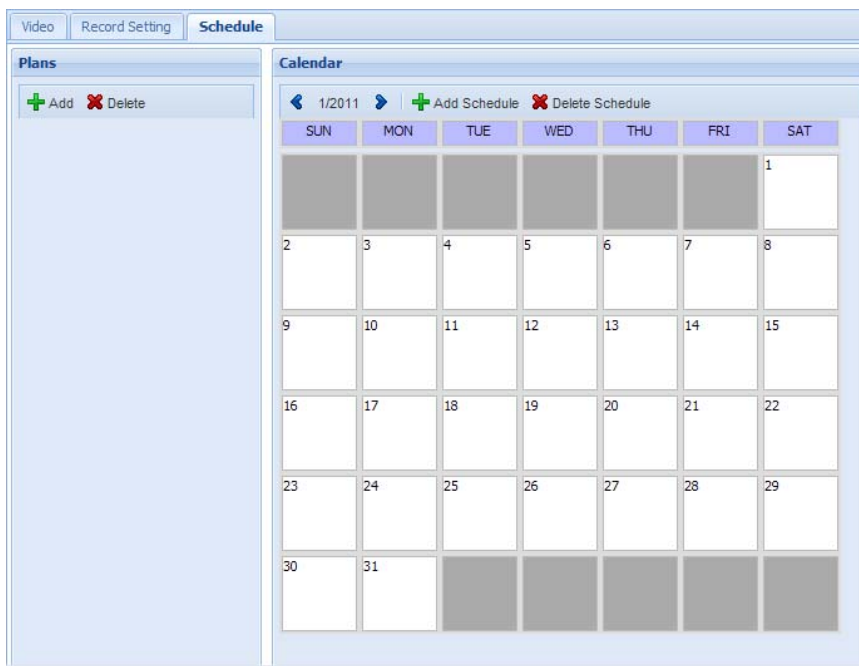



Figure 5-20

1. Click **Add**  under **Plans** and type a name for the schedule plan.
2. Double-click the schedule plan. This dialog box appears.

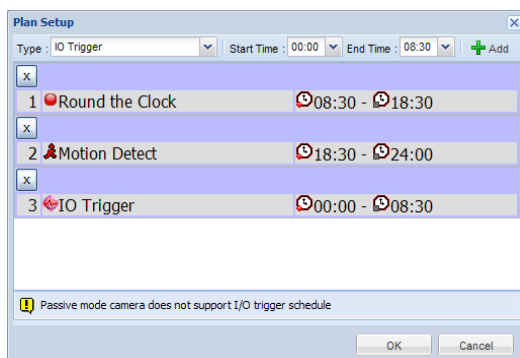

Figure 5-21

3. Use the **Type** drop-down list to select from Round the Clock, Motion Detection or I/O Trigger.

4. Select a **Start Time** and an **End Time** to apply the recording policy specified above and click the **Add** button.
5. Optionally repeat steps 3 and 4 to set different recording policies for other time periods. Click **OK**.
6. Under Calendar, click **Add Schedule**. This dialog box appears.

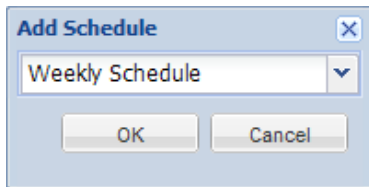

Figure 5-22

- a) To apply the schedule plan created to a particular day of the week continuously, select **Weekly Schedule** and click **OK**. In the dialog box that appears, select a schedule plan and the desired day of the week for it to be applied.

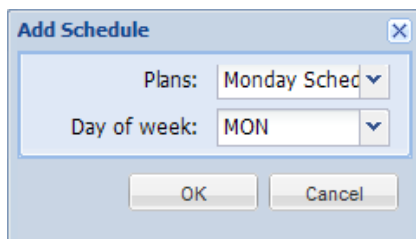

Figure 5-23

- b) To apply the schedule plan to a specific date, select **Special Day Schedule** and click **OK**. In the dialog box that appears, select a schedule plan and the desired date.

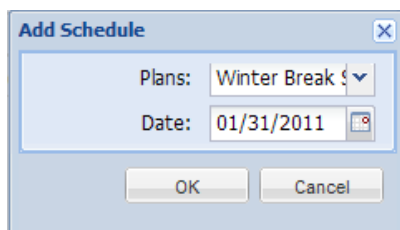

Figure 5-24

7. Click **Save**.

5.2.3 Motion Detection

Set up motion detection to generate a notification or start recording whenever movement occurs in the video image. You can set up to 8 motion detection areas with different sensitivity values.

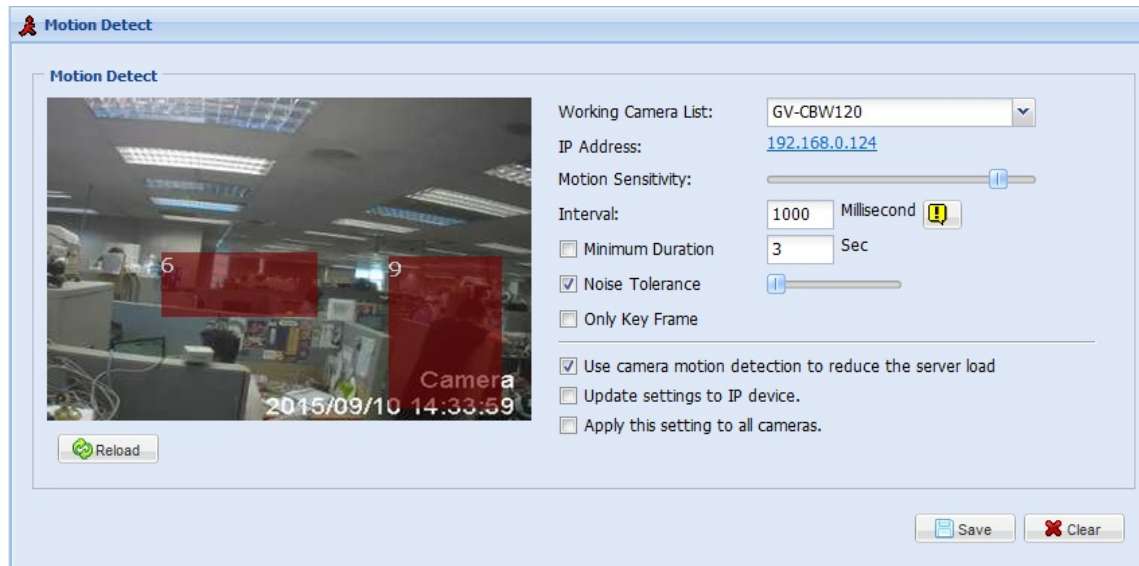

Figure 5-25

1. Select a camera under **Working Camera List**.
2. Motion detection is applied to the entire image by default. To adjust the sensitivity value, right-click on the detection area and click **Motion Sensitivity**.
3. To redefine the detection area, right-click on the default area and click **Delete**.
4. To set a new area, move the sensitivity value slider on the right as desired. The higher the value, the more sensitive the camera is to motion.
5. Click and drag for a desired area on the image and click **Add** when you are prompted to confirm the setting.
6. To create several areas with different sensitivity values, repeat steps 4 and 5.

More Motion Detection Settings:

- **Interval:** Set the frequency of motion detection. The smaller the value, the more precise it is.
- **Minimum Duration:** Set the length of time the motion must persist for motion detection to be triggered.
- **Noise Tolerance:** Distinguishes noise from motion. The higher the value, the higher the level of noise the camera can tolerate.

- **Only Key Frame:** Select to detect motion only from key frames.
- **Use camera motion detection to reduce server load:** Select to use the motion detection function on the camera, as opposed to the server, to reduce server load.
- **Update settings to IP device:** Select to overwrite the motion detection settings set on the camera's Web interface.
- **Apply this setting to all cameras:** Select to apply the motion detection settings to all cameras within *Working Camera List*.

Click **Save** to apply the setting changes.

Note:

1. The **Minimum Duration** and **Noise Tolerance** functions are only available for the motion detected by GV-Recording Server. To use these functions, you must deselect **Use camera motion detection to reduce the server load**.
 2. The **Update settings to IP device** function is only supported by GV-IP Devices, but not including GV-ABL series / ADR series / AVD series / EBD series / TBL series / TDR series / TVD series.
-

You can now set up e-mail notifications to be sent or to start recording upon motion detection. Refer to *5.3.6 Notification* and *5.2.2 Camera Setting* to see how to set up notifications and record policy.

5.3 Server

In the Server section, you can start services, configure general setup, specify storage path, modify Video Gateway ports, and set up e-mail notifications.

5.3.1 Service

The Recording Server service must be started to record videos from connected IP devices and the Video Gateway service must be started to receive and stream videos.

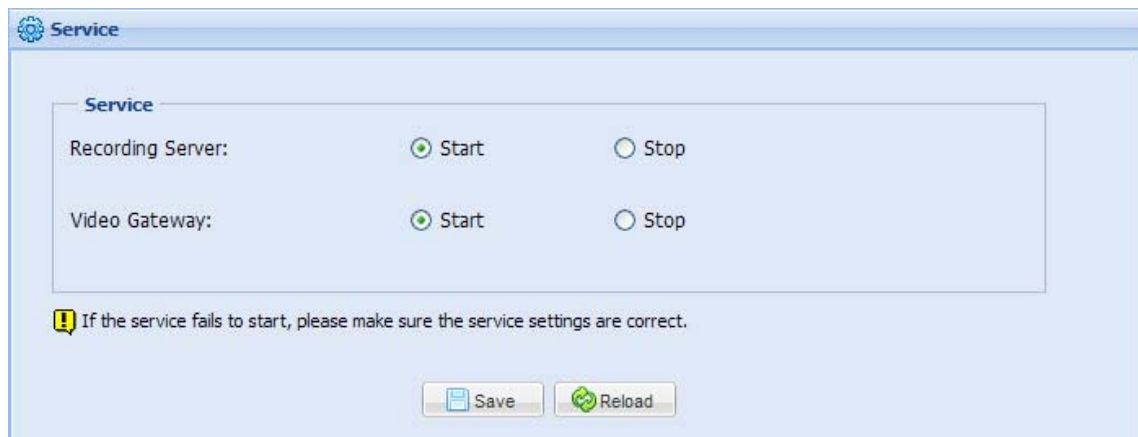

Figure 5-26

5.3.2 Install Wizard

When logging into GV-Recording Server for the first time, you'll be prompted with the Install Wizard in guiding you to add IP devices, assign storage path for the recordings and set up connections. Refer to *Chapter 3 Getting Started* for details.

5.3.3 General Setup

In the General Setup page, you can configure the command port of GV-Recording Server, its system log settings and allow GV-IP Devices to connect through passive connection.

The screenshot shows the 'General Setup' configuration page. It is organized into four main sections:

- General Setup:**
 - Server Name:
 - Command Port:
 - Auto Start Recording: Yes No
- Camera Setting:**
 - Text Overlay Setting: Use Server Side Setting
 - Skip Setting of IP Camera: Yes No
 - Standard codec: Yes No
 - Sync time with PC:
- System Log:**
 - Keep Days(0: unlimited):
 - Recycle: Yes No
 - Backup Settings:
 - Enable
 - Backup Path:
 - Time Setting:
 - Time to Send System Report by email:
- Allow Geo IP Device Login:**
 - Allow Geo IP Device Login
 - User Name:
 - Password:
 - Connect Port:

At the bottom of the page, there are two buttons: and .

Figure 5-27

[General Setup]

- **Server Name:** Type a name to identify the GV-Recording Server. The default is the computer's name.

- **Command Port:** Used for running the recording server program. The default command port is 20000, while reserving the 20 ports following it, altogether from 20000 to 20019. If another program is using any of the default ports, modify it accordingly to avoid conflict.
- **Auto Start Recording:** Automatically start recording upon starting of the GV-Recording Server service.

[Camera Setting]

- **Text Overlay Setting:** Select **Use Sever Side Setting** to display the time and/or camera name on the camera image. You can choose to display on the **Recording Stream** and/or **Preview Stream**.
 - Ⓒ **Overlaid with time stamps:** Include time stamps on live and/or recorded videos.
 - Ⓒ **Overlaid with camera's display name:** Include camera names on live and/or recorded videos.
- **Skip Setting of IP Camera:** Enable this option to keep the current codec and resolution settings of IP cameras upon system restarts.
- **Standard Codec:** Enable this option to encode the videos in the standard H.264 codec which allows you to play the recordings with any player.
- **Sync time with PC:** Select a time to synchronize the time of all connected IP devices with that of the PC running GV-Recording Server.

[System Log]

- **Keep days (0 = unlimited):** Specify the number of days to keep the system log for.
- **Recycle:** Enables recycling of system log.
- **Backup Settings:** Select to assign a storage path and time to back up system log. The default path is the first available HDD next to the *System HDD*, e.g. if C:\ is the system HDD, then it is stored at *D:\ERS\SystemLog*.
- **Time to Send System Report by email:** Select a specific day of week to send system report PDF via e-mail periodically, containing data including server information, disk health status and statistics of the IP device connection list. See *5.4.3 Mail Server* to set up the mail server.

[Allow Geo IP Device Login] Select this option to allow GV-IP devices to connect to GV-Recording Server. Type a user name, password and connect port for the IP devices to connect. Refer to *4.2 Passive Connection* for more details.

5.3.4 Storage Path

In the Storage Path page, you can set a storage path for each camera to store its recordings and specify the storage usage threshold for recycling them. Refer to *To Assign Storage Paths, Chapter 3 Getting Started* for details.

Note: When a camera begins recording, a shortcut path will be created, linking the camera to the storage path of its recording. By default, the shortcut folders are located at C:\Programs Files (x86)\RecordingServer\shortcuts.

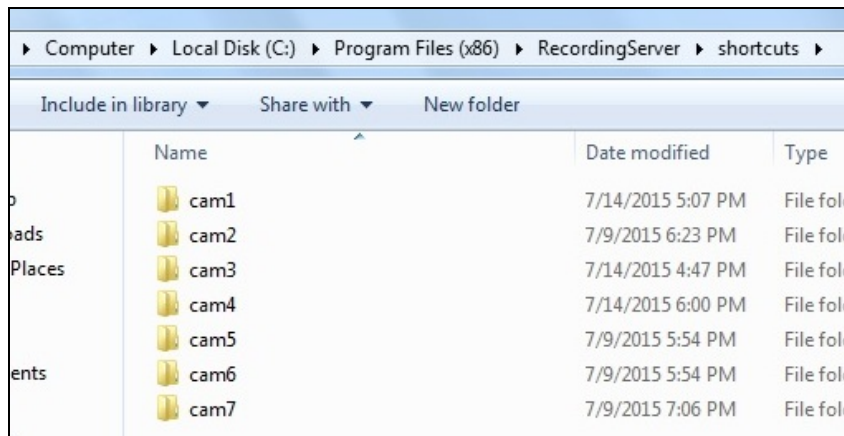

The screenshot shows a Windows File Explorer window with the address bar set to 'Computer > Local Disk (C:) > Program Files (x86) > RecordingServer > shortcuts'. The main area displays a table of folders:

Name	Date modified	Type
cam1	7/14/2015 5:07 PM	File folder
cam2	7/9/2015 6:23 PM	File folder
cam3	7/14/2015 4:47 PM	File folder
cam4	7/14/2015 6:00 PM	File folder
cam5	7/9/2015 5:54 PM	File folder
cam6	7/9/2015 5:54 PM	File folder
cam7	7/9/2015 7:06 PM	File folder

Figure 5-28

5.3.5 Video Gateway

The Video Gateway page allows you to configure the connection settings for TCP/IP, Multicast streaming, RTSP protocol and enable Video Relay.

TCP/IP

Connection Port:

Max. Connection(s){1~600}:

Auto Start: Yes
 No

AES Protection: Yes
 No

Camera List:

Multicast

Network Interface Card:

Multicast: Enable

RTSP

RTSP/TCP Port:

RTP/RTCP/UDP Port:

Max. Connection(s):

Authentication: Yes
 No

Video Relay

Enable: Yes
 No

QR code for GV-Eye access: 

Enable Economic Mode

JPEG: Motion: FPS
Non-Motion: FPS

H264/H265: Motion:
Non-Motion:

Camera List:

Figure 5-29

[TCP/IP]

- **Connection Port:** The default TCP/IP port is 11000.
- **Max. Connection(s)(1~600):** Specify the maximum number of channels transmitted to clients. Default is 600 channels.
- **Auto Start:** Automatically connects to IP devices upon starting of GV-Recording Server.
- **AES Protection:** Enable AES protection for camera streams transmitted by GV-Recording Server.
- **Camera List:** Click **Edit** to specify the channels to be transferred.

Note: Accessing of AES-encrypted streams is only supported by GV-VMS V17.3, GV-Control Center V3.6.0, GV-Edge Recording Manager for Windows V1.4.0.0, GV-Remote ViewLog V17.2 and GV-Eye for Android / iOS V2.7.2 or later versions.

[Multicast] The multicast sends the video and audio streams of connect IP devices onto a designated IP address to be accessed by multiple hosts.

- **Network Interface Card:** Select a Network Card to run multicast on a different network. Since the multicast can take a lot of bandwidth when enabled, separating it from the main network is advised whenever possible.
- **Multicast:** Select **Enable** to activate and send video and audio streams to the multicast address.
 - **Update Period:** Specify the time interval, in seconds, between updating multicast streams.
 - **IP Address:** Type the IP address used for multicast. Only the hosts with the same multicast IP can receive the multicast streams. The default IP address is 224.1.1.2.
 - **Port:** Type the port number used for multicast. The default port number is 8300.
 - **Password:** Optionally type a password for securing the multicast streams. The hosts will be required to enter the password upon accessing.

For details on accessing multicast streams, see *7.3 Connecting with Multicast*.

[RTSP] You can connect to IP devices through RTSP protocol if the protocol is supported by the IP device.

- **RTSP/TCP Port:** The default port number is 554.
- **RTP/RTCP/UDP Port:** The default port ranges from 17300 to 17380.

- **Max. Connection(s) (1~300):** Specify the maximum number of RTSP connections allowed.
- **Authentication:** Select **Yes** for requiring the user to enter the necessary authentication info, such as *username* and *password*, upon connecting via RTSP.

Note:

1. Only VLC media player and QuickTime Player are supported for streaming H.264 video via RTSP protocol.
2. For more details on how to connect to IP devices through RTSP, see *Appendix B. RTSP Protocol Support*.

[Video Relay] Allows mobile app GV-Eye to connect to GV-Recording Server, V2.0.0 or later, by scanning of the QR code.

- **Enable:** Select **Yes** to allow GV-Eye to access the camera images of GV-Recording Server.

[Enable Economic Mode] You can choose to receive camera images with specific frame settings using the Economic Mode to conserve network bandwidth.

- **JPEG:** Specify the number of frame rates per second to receive in JPEG codec during motion and non-motion events.
- **H264/H265:** Select to receive camera images in maximum frame rates or receive only the key frames in H.264/265 codec during motion and non-motion events.
- **Camera List:** Click **Edit**  **Edit** and select at least one camera to enable the Economic Mode settings.

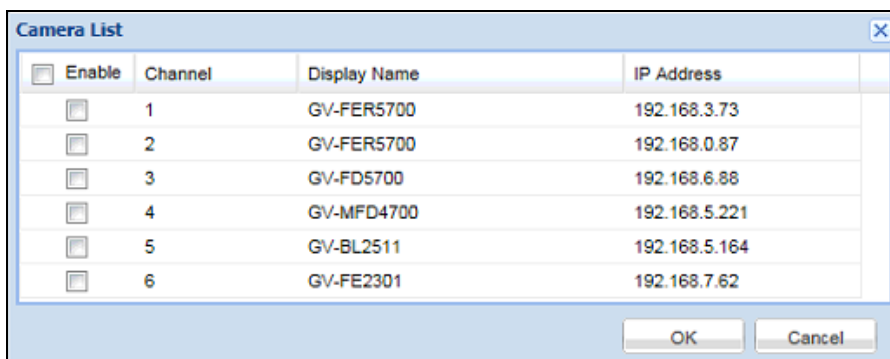

Figure 5-30

Click **Save** for the changes to take effect.

5.3.6 Notification

GV-Recording Server can be set to send e-mail notifications for the following conditions:

- Active device connection lost
- USB protection key removed
- USB protection key inserted
- Passive device connection lost
- Recycling of recorded video
- Start keep days operation
- Motion detection
- Disk full
- Disk error
- Disk removed
- Recording failure

To send e-mail alerts, select the desired condition and enable **Send E-mail Alerts**.

The screenshot shows the 'Alert Setting' window. On the left, a list of conditions is displayed. On the right, the 'Send e-mail alerts' section has the 'Yes' radio button selected. Below it, the 'Interval' and 'Minimum Duration' sections each have an unchecked checkbox and a text input field containing '60' and '30' respectively, followed by 'Sec'. An 'E-Mail' button is located to the right of the 'Send e-mail alerts' section. At the bottom of the window, there are 'Save' and 'Reload' buttons.

Figure 5-31

For certain conditions, you can set a minimum **time interval**, in seconds, between e-mail alerts, which include:

- Camera Connection Lost
- Passive Geo IP Device Connection Lost
- Motion Detection
- Disk Full
- Disk Error
- Disk Removed
- Recording Failure

You can set a **minimum duration** time, in seconds, in which the condition has to persist for before an e-mail alert is sent:

- Camera Connection Lost
- Passive Geo IP Device Connection Lost
- Motion Detection
- Recording Failure

If the mail server has not been set, click the **E-Mail** button to go to the Mail Service page.

For details on the Mail Service settings, see *5.4.3 Mail Service*.

Note: You can also send e-mail notifications for I/O Trigger by enabling **E-mail Alarm** in the Recording Setting page (Camera Setting > Record Setting tab > I/O Device Setting). See *5.2.2.B Record Setting*.

5.4 Network

The Network section includes the settings for basic network configurations, communication ports, e-mail service for alert notifications, Remote ViewLog for remote playback and SNMP protocol.

5.4.1 Network

In the Network page, you can configure the basic network settings as well as set up SSL protocol and Dynamic DNS.

Network

Information

Network Interface Card: Intel(R) 82574L Gigabit Network Connection #3(192.168.0.168) ▼

Mac Address: 20-46-A1-00-31-3A

IP Address: 192.168.0.168

Subnet mask: 255.255.248.0

Gateway: 192.168.0.1

DNS1: 192.168.0.1

DNS2:

Setup

HTTP Port: 80

SSL: Enable

Port: 443

Certificate File(.crt): server.crt Browse

Certificate Key File(.key): server.key Browse

Certificate Chain File(.crt): ca.crt Browse

Save Reload

DDNS

Enable: Yes No

Network Interface Card: Intel(R) 82574L Gigabit Network Connection #3(192.168.0.168) ▼

Service provider: Geovision DDNS Server V2 ▼ [Example: Register GeoVision's DDNS host.](#)

Host Name: lumbergh.dipmap.com

User Name: lumbergh

Password: ●●●●●●

Status:

Save Reload

Figure 5-32

[Information]

- **Network Interface Card:** Select a Network Interface Card to connect to the Internet.

[Setup]

- **HTTP Port:** The default HTTP port is 80.
- **SSL:** Enable the Secure Sockets Layer (SSL) protocol for a more secured Internet connection. To use your own Certificate File, Certificate Key File and Certificate Chain File, click the **Browse** buttons and select the files stored at your local PC. The encryption strength depends on your SSL certificate.

[DDNS] Dynamic DNS allows you to register a domain name to easily access your GV-Recording Server when using a dynamic IP address.

- **Enable:** Select **Yes** to enable DDNS.
- **Network Interface Card:** Select a Network Interface Card to connect to the Internet when there is more than one Network Interface Card is installed on the PC.
- **Service Provider:** Select a DDNS service provider. If you select GeoVision DDNS Server, click the link on the right for service registration.
- **Host Name:** Type the host name used to connect to the GV-Recording Server. The host name registered on GeoVision DDNS Server is created by adding “.dipmap.com” to the username.
- **ID:** Type the username used to enable the DDNS service.
- **Password:** Type the password used to enable the DDNS service.

5.4.2 Port Setting

You can see all communication ports used by the GV-Recording Server. If your server is installed with a router or firewall, make sure the related communication ports are open. To modify any port number, click the field and click **Save** for the changes to take effect.

The screenshot shows the 'Port Setting' configuration window with the following fields and values:

Section	Field	Value
General setup	Command Port *	20000
	GV-IP Device Login Port:	50000
Video Gateway	Connect Port *	11000
	RTSP/TCP Port:	554
	RTP/RTCP/UDP Port:	17300
		17380
Remote ViewLog	Connect Port *	5552
Network	HTTP Port *	80
	SSL:	443

At the bottom of the window, there is a warning icon and the text: **!** * means can't be empty. Below this are two buttons: **Save** and **Reload**.

Figure 5-33

Note:

1. If the GV-Recording Server is installed behind a firewall or router, you may need to open these default ports: HTTP port 80, server connection port (Active connection port) 11000, Passive connection port 50000, remote playback (Remote ViewLog) port 5552.
2. The Command port is used for running the recording server services. By default, 20 ports are reserved, ranging from 20000 to 20019, for the program use. If another program is using any of the default ports, a port conflict may occur.

5.4.3 Mail Service

GV-Recording Server can be set to send e-mail alerts when any of the following conditions occur:

- Active device connection lost
- Passive device connection lost
- USB protection key removed
- USB protection key inserted
- Recycling of recorded video
- Start keep days operation
- Motion detection
- Disk full
- Disk error
- Disk removed
- Recording failure

To send e-mail alerts, you have to configure the following mail server settings and specify the sending and receiving e-mail addresses.

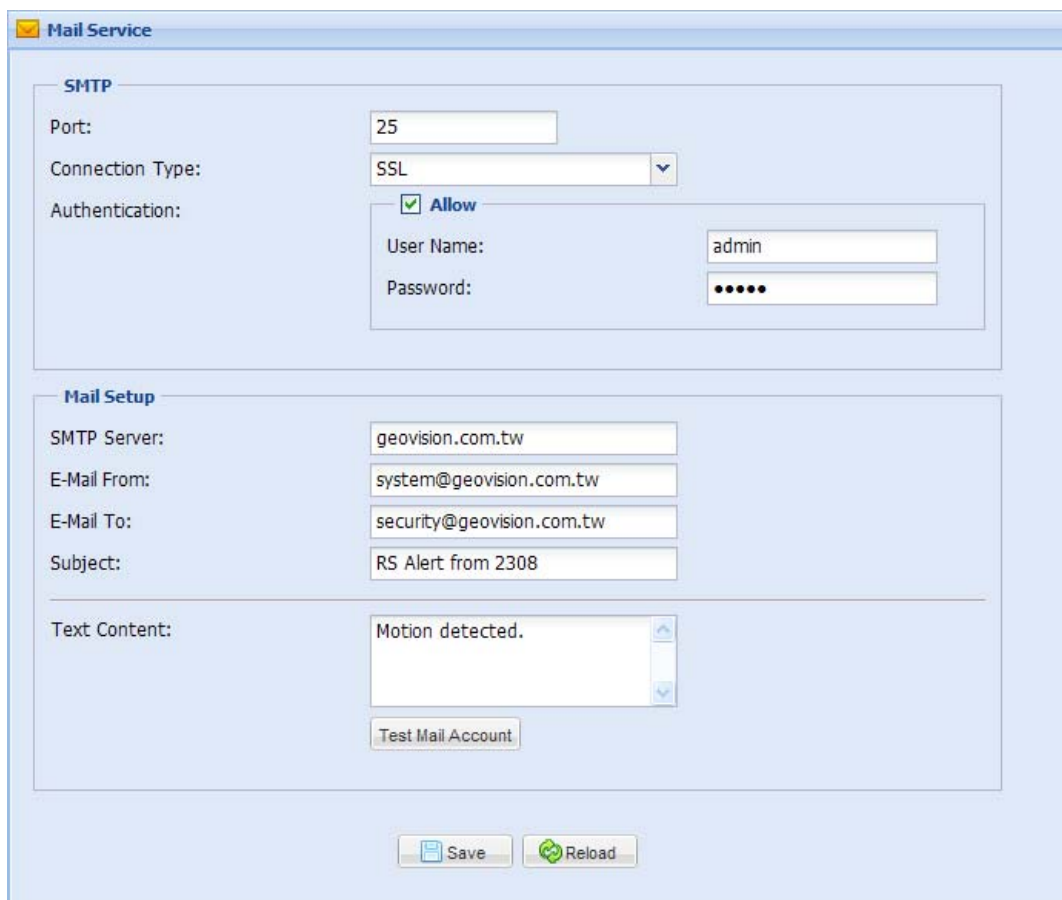

The screenshot shows a web-based configuration window titled "Mail Service". It is divided into two main sections: "SMTP" and "Mail Setup".

SMTP Section:

- Port: 25
- Connection Type: SSL
- Authentication: Allow
- User Name: admin
- Password: [masked]

Mail Setup Section:

- SMTP Server: geovision.com.tw
- E-Mail From: system@geovision.com.tw
- E-Mail To: security@geovision.com.tw
- Subject: RS Alert from 2308
- Text Content: Motion detected.
- Test Mail Account: [button]

At the bottom of the window, there are two buttons: "Save" and "Reload".

Figure 5-34

[SMTP Setting]

- **Port:** The default port for most SMTP servers are 25. However, webmail Yahoo and Hotmail generally use different SMTP ports. Check with your e-mail provider for the SMTP port used.
- **Connection Type:** For a more secure connection, use the drop-down list to select **SSL** or **TLS/STARTTLS**.
- **Authentication:** If your mail server needs login authentication, select **Allow** and type its account name and password accordingly.

[Mail Setup]

- **SMTP Server:** Type your mail server's URL or IP address.
- **E-Mail From:** Type the sender's e-mail address.
- **E-Mail To:** Type the recipient's e-mail address. For multiple recipients, add a semicolon between each e-mail address.
- **Subject:** Type a subject for the alert message.
- **Text Content:** Type the content for the alert message.
- **Test Mail Account:** Click to send a test e-mail from and to the assigned accounts.

5.4.4 Remote ViewLog

Through the network, you can remotely access and view the videos recorded by GV-Recording Server. To see how to connect to GV-Recording Server using Remote ViewLog, see *7.5 Connecting with Remote ViewLog*.

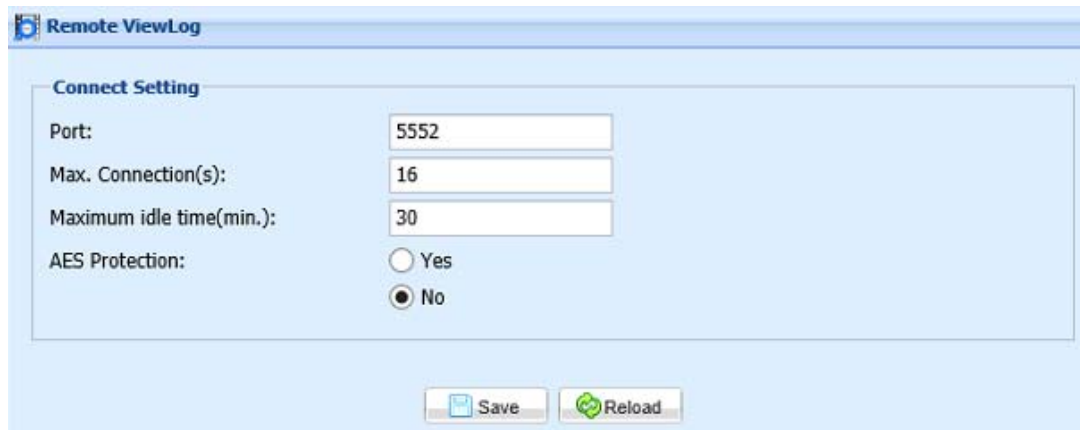

Figure 5-35

- **Port:** Keep the default port 5552 or modify it to match that of the Remote ViewLog.
- **Max. Connection(s):** Specify number of maximum simultaneous connections.
- **Maximum idle time (min.):** Users connecting from Remote ViewLog will be disconnected after being idle longer than the time period specified.
- **AES Protection:** Enable AES protection for recordings accessed remotely by GV-Software.

Note: Accessing of AES-encrypted streams is only supported by GV-VMS V17.3, GV-Control Center V3.6.0, GV-Edge Recording Manager for Windows V1.4.0.0, GV-Remote ViewLog V17.2 and GV-Eye for Android / iOS V2.7.2.

5.4.5 SNMP

GV-Recording Server can be set to send alarm alerts through SNMP for 3rd-party applications for the following conditions:

- Camera connection lost
- Camera connection resumed
- Disk full
- Disk error

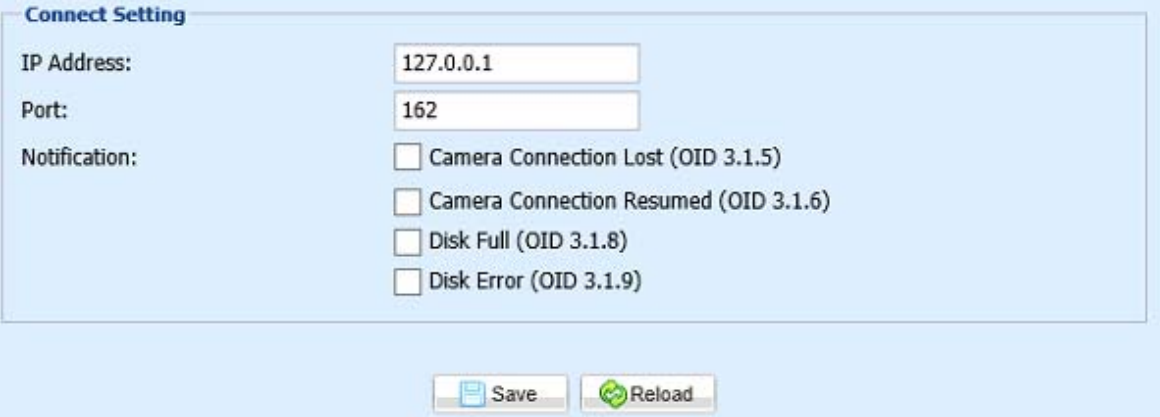

Connect Setting

IP Address: 127.0.0.1

Port: 162

Notification:

- Camera Connection Lost (OID 3.1.5)
- Camera Connection Resumed (OID 3.1.6)
- Disk Full (OID 3.1.8)
- Disk Error (OID 3.1.9)

Save Reload

Figure 5-36

[Connect Setting]

- **IP Address:** The default IP address is 127.0.0.1.
- **Port:** Default port is 162.

5.5 Advanced Management

The Advanced Management section allows you to set up E-map, connection to GV-GIS, user accounts and advanced query.

5.5.1 E-map

E-Map displays the area being monitored on Google Maps, which allows the operator to easily locate the physical location of the connected IP devices.

Note: By default, the built-in Open Street Map, a free service, is used. To use Google Map, users must first purchase an API key from Google.

To set up E-Map:

1. Click **E-Map Editor** at the bottom of the E-map page. This window appears.

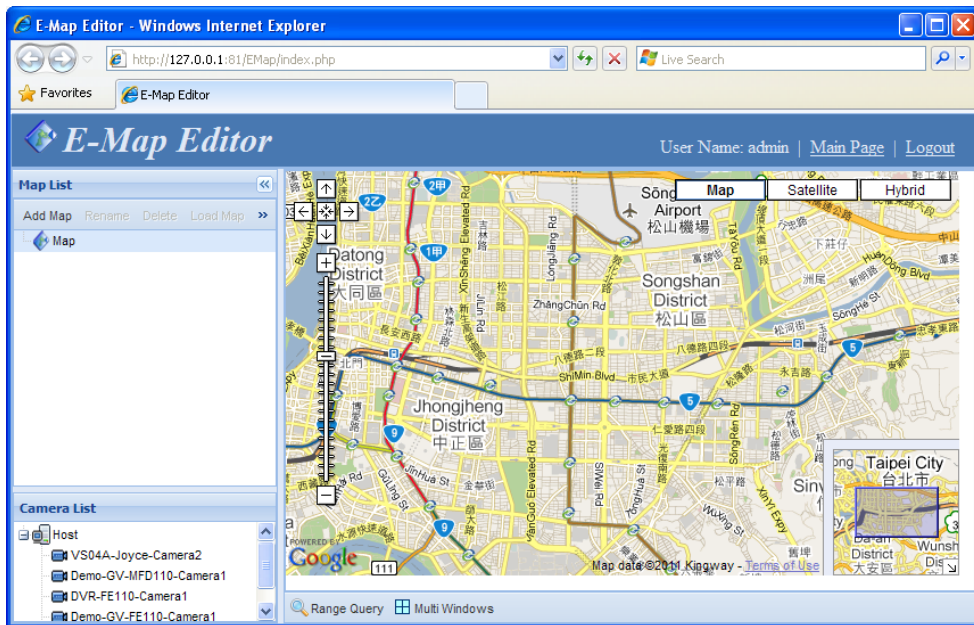

Figure 5-37

2. Drag the camera from the Camera List and drop it onto the map to indicate the location of the camera.

3. Right-click the camera icon and click **Live View** to see the live view of the camera.



Figure 5-38

4. Right-click the camera icon and click **Street View** to see the Google street view of the camera location.

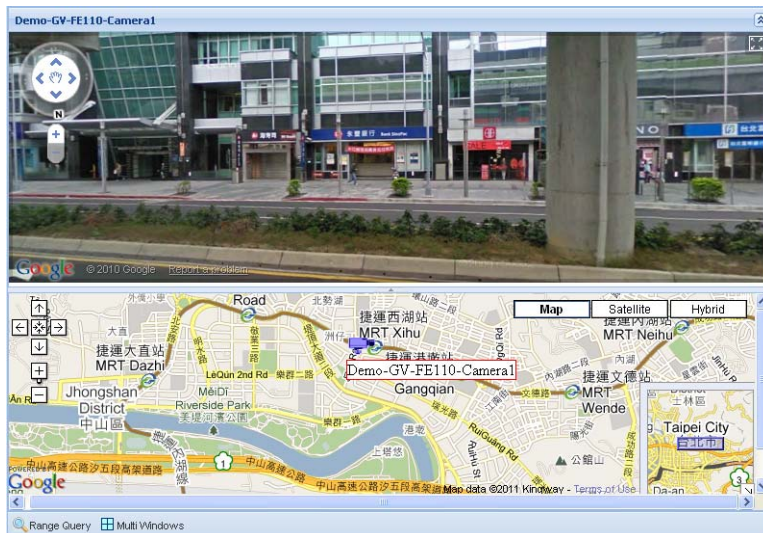

Figure 5-39

5. To change the direction of the camera icon, right-click the icon and select a direction.
6. At the bottom of the page, you can click **Range Query** and a circular area will be highlighted on the map. You can adjust the location and size of the circular and click **Multi Windows** to see the live view of all cameras enclosed within.

7. To insert a floor plan onto the Google map, click **Add Map** under Map List. This dialog box appears.

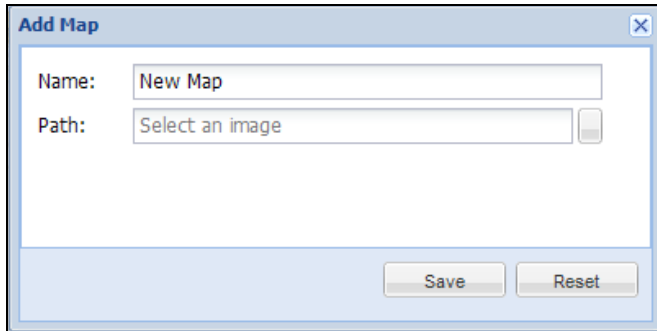

Figure 5-40

8. Type a name for the map and select the path of the graphic file. Click **Save**. A map icon will be created on the Google map.
9. Double-click the map icon and drag the cameras onto the map from the Camera List.

Note: To view Google street view, you need to install Adobe Flash Player version 10 or later. The Google street view may not be available in your location.

5.5.2 GIS

You can send the GPS data of connected IP devices to the GV-GIS for location verification and vehicle tracking. The GPS data can be sent to up to 4 GV-GIS stations simultaneously.

To connect with the GV-GIS, the **Mobile Host** accounts for each IP device must be created at the GV-GIS in advance. For details, see [GV-GIS User's Manual](#).

Note: The GV-Recording Server is only compatible with GV-GIS V 3.0 or later.

1. Select a GV-GIS server and click **Edit** .

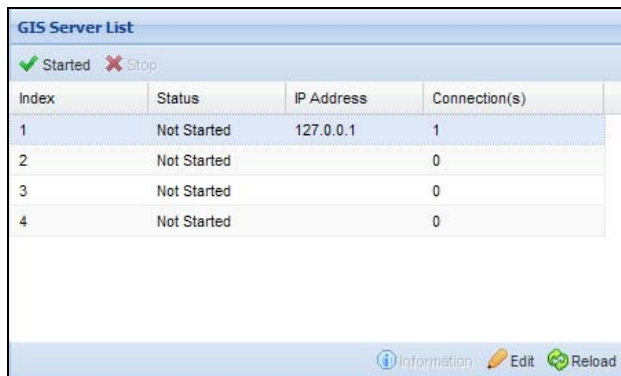

Figure 5-41

2. Type the **IP Address** of the GV-GIS. Keep the default port 3356 or modify it to match that of the GV-GIS.

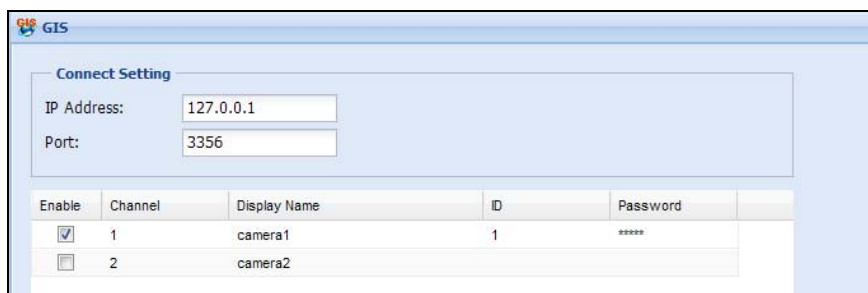

Figure 5-42

3. Select the desired cameras.
4. Click and type the **ID** and **Password** created on the GV-GIS for each camera.
5. Click **Save** and return to the GIS Server List. The total number of to-be-connected IP cameras is displayed in the GIS Server List.
6. Select the GV-GIS server and click **Start** to connect. Once connected, you can click the **Information** button to see its connection status.

5.5.3 VSM

You can connect the GV-Recording Server to one GV-Vital Sign Monitor (GV-VSM) to send text message alerts when any of the following conditions occurs:

- Motion detected
- Camera connection lost
- Camera connection resumed
- Video lost
- Video resumed
- Recording Server / Video Gateway service started or stopped
- Disk full on GV-Recording Server
- Disk error on GV-Recording Server

For details on GV-Vital Sign Monitor, see [GV-CMS Series User's Manual](#).

Note:

1. GV-VSM only supports up to 128 channels of GV-Recording Server.
 2. The GV-Recording Server is only compatible with GV-Vital Sign Monitor of version 8.5.9.0 or later.
-

To connect to GV-Vital Sign Monitor:

1. Click **Edit** . Type the **IP Address**, **Port**, **User Name** and **Password** of the GV-VSM.

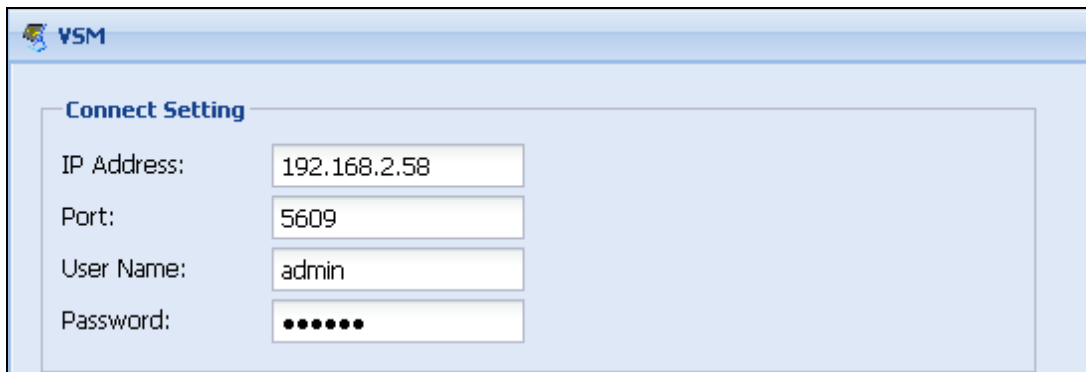

The screenshot shows a dialog box titled "VSM" with a "Connect Setting" section. It contains four input fields: "IP Address" with the value "192.168.2.58", "Port" with the value "5609", "User Name" with the value "admin", and "Password" with a masked password represented by seven dots.

Figure 5-43

- Under the Working Camera List, select the desired cameras for the GV-VSM to monitor for.

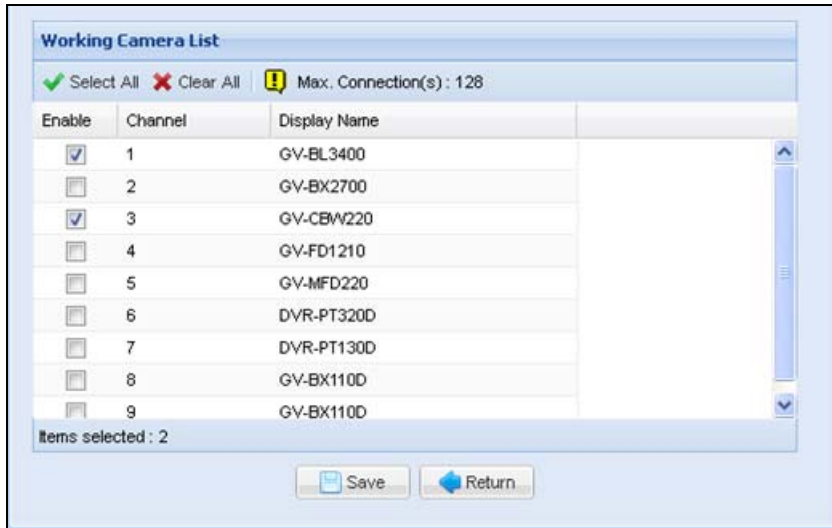

Figure 5-44

- Click **Save** to apply the settings.
- Click **Start** to start the connection.

After the GV-Recording Server is successfully connected to the GV-VSM, a "Connected" message will appear in the Status column.



Figure 5-45

5.5.4 Backup Center

The recordings on GV-Recording Server can be backed up to GV-Backup Center automatically to keep an additional copy in case of data loss or damage.

Note: For requirements of connecting to GV-Backup Center, see [1.1.6 Requirements for Connecting to GV-Backup Center](#).

To connect to GV-Backup Center:

1. Click **Edit** . Type the **IP Address**, **Port**, **User Name** and **Password** of the GV-Backup Center.

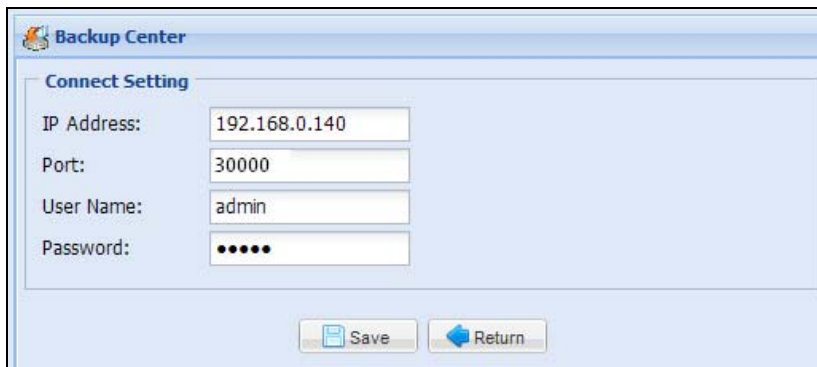

The screenshot shows a dialog box titled "Backup Center" with a "Connect Setting" section. It contains four input fields: "IP Address" with the value "192.168.0.140", "Port" with "30000", "User Name" with "admin", and "Password" with five dots. At the bottom, there are two buttons: "Save" and "Return".

Figure 5-46

2. Click **Save** to apply the settings.
3. Click **Start** to start the connection.

After the GV-Recording Server is successfully connected to the GV-Backup Center, a "Connected" message will appear in the Status column.

5.5.5 Failover Server

Your recordings can be backed up to GV-Failover Server / Redundant Server automatically in case of the failure of GV-Recording Server. GV-Failover Server currently does not support CH129~256 of GV-Recording Server.

To connect to GV-Failover Server / Redundant Server:

1. Click **Edit** . Type the **IP Address**, **Port**, **User Name** and **Password** of the GV-Failover Server / Redundant Server.

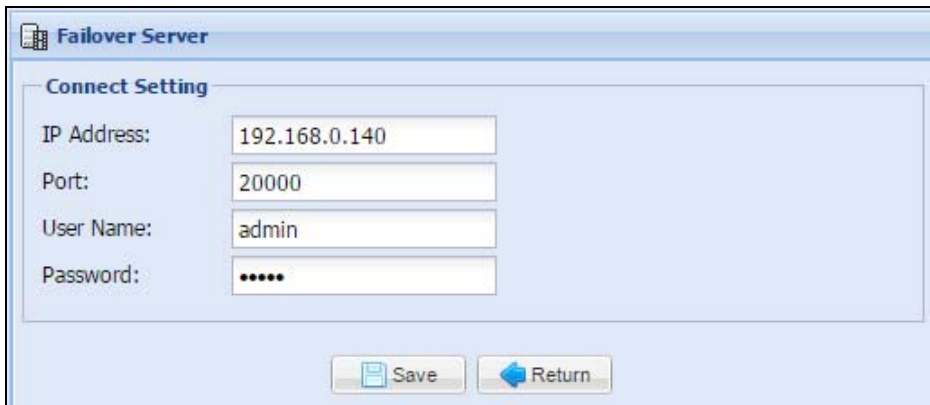

The screenshot shows a window titled "Failover Server" with a "Connect Setting" section. The settings are as follows:

Field	Value
IP Address:	192.168.0.140
Port:	20000
User Name:	admin
Password:	•••••

At the bottom of the window, there are two buttons: "Save" and "Return".

Figure 5-47

2. Click **Save** to apply the settings.
3. Click **Start** to start the connection.

After the GV-Recording Server is successfully connected to the GV-Failover Server / Redundant Server, a "Connected" message will appear in the Status column.

Note: GV-IP devices connected through passive connection is currently not supported by GV-Failover Server / Redundant Server.

5.5.6 GV-PoE Switch

You can power off PoE ports on a GV-PoE Switch to help control the power usage of connected IP devices. The GV-Recording Server will detect GV-PoE Switch automatically under the same LAN.

To enable / disable a PoE port:

1. In the Switch List, double-click an IP address or click **Edit**  to access the settings of the GV-PoE Switch.
2. Type the **Username** and **Password** of the PoE switch. The default ID and Password are admin.

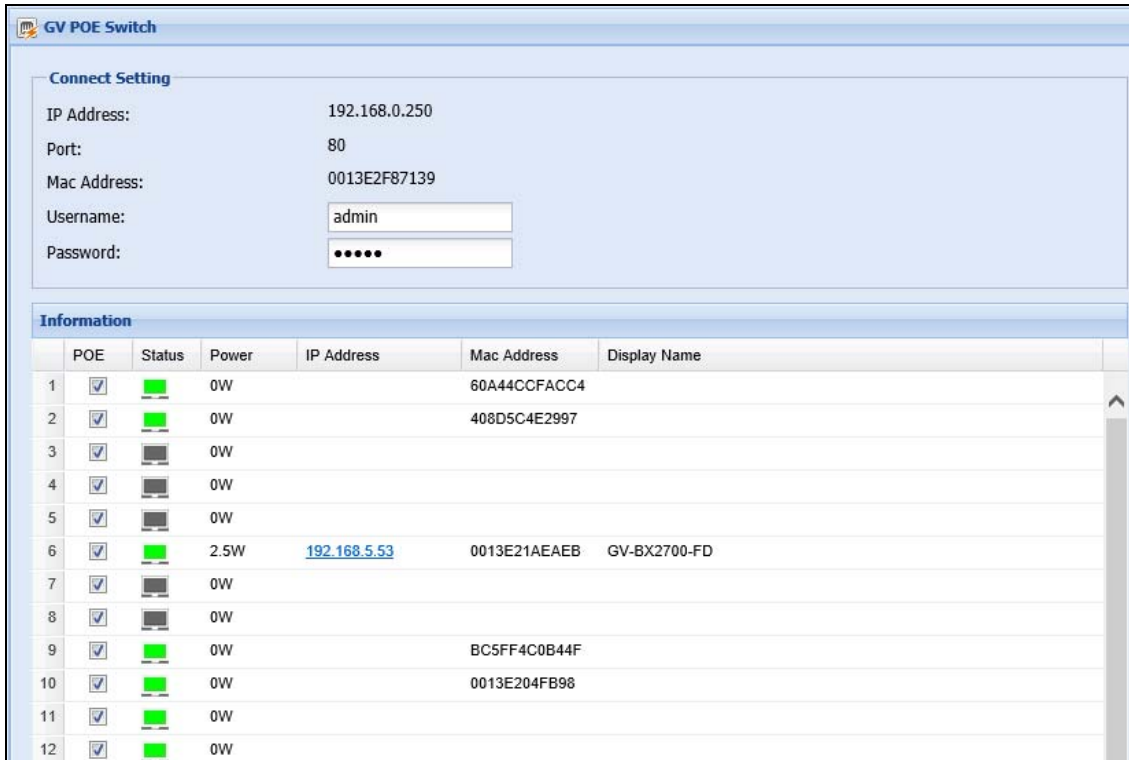

	POE	Status	Power	IP Address	Mac Address	Display Name
1	<input checked="" type="checkbox"/>	■	0W		60A44CCFACC4	
2	<input checked="" type="checkbox"/>	■	0W		408D5C4E2997	
3	<input checked="" type="checkbox"/>	■	0W			
4	<input checked="" type="checkbox"/>	■	0W			
5	<input checked="" type="checkbox"/>	■	0W			
6	<input checked="" type="checkbox"/>	■	2.5W	192.168.5.53	0013E21AEAEB	GV-BX2700-FD
7	<input checked="" type="checkbox"/>	■	0W			
8	<input checked="" type="checkbox"/>	■	0W			
9	<input checked="" type="checkbox"/>	■	0W		BC5FF4C0B44F	
10	<input checked="" type="checkbox"/>	■	0W		0013E204FB98	
11	<input checked="" type="checkbox"/>	■	0W			
12	<input checked="" type="checkbox"/>	■	0W			

Figure 5-48

3. Under **Information**, select or deselect a **POE** checkbox to enable or disable its POE function. The green color indicates the status of a powered POE port, whereas the grey color indicates a POE port that's been turned off or not in use.
4. Click **Save** to apply the settings.

GV-Recording Server can power off and restart the ports of any GV-PoE Switch.

1. Select a GV-PoE Switch on the **Switch List** and click **Setup** . This dialog box appears.

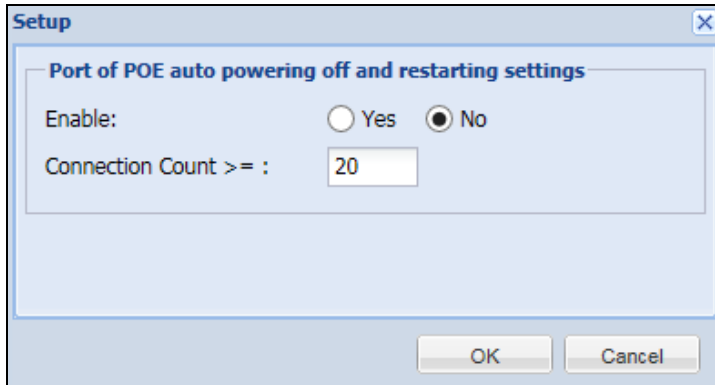

Figure 5-49

2. To enable the automatic shutdown and restart of the ports, select **Yes**.
3. In **Connection Count**, specify the number of connection attempts from GV-Recording Server before powering off and restarting.
4. Click **OK**.

5.5.7 GV-Cloud Center

GV-Cloud Center is a cloud-based service that allows you to receive notifications, search events, access live view and playback recordings of the connected GV-Recording Server. For more details, refer to 2.3 *Connecting GV-Recording Server to Cloud Center* in the [GV-Cloud Center User Manual](#).

5.5.8 Live Stream Sharing

You can live stream the camera image on YouTube either through Stream now or Events. YouTube Stream now enables immediate sharing of live events without additional configurations. This section introduces how to live stream with YouTube Stream now. To preview and schedule a live event in advance, see *Appendix G Setting Live Streaming on YouTube*.

Note: A maximum of 16 channels are supported for live streaming and only using H.264 codec.

1. In the left menu, click **Server > Service** and disable **Video Gateway** service first.
2. In the left menu, click **Advanced Management > Live Stream Sharing**.
3. Click **Live stream camera on YouTube**. The YouTube dashboard page appears.

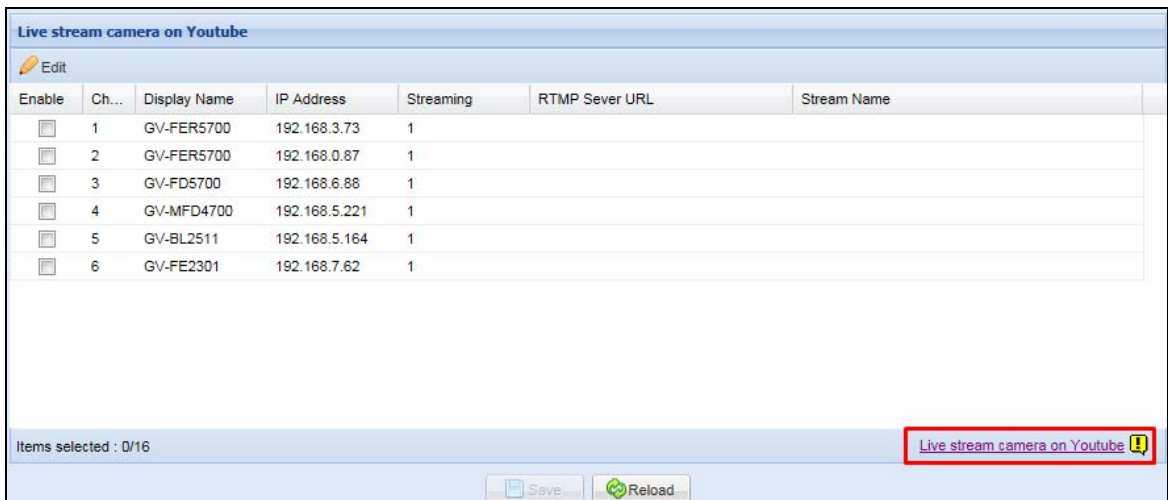

Enable	Ch...	Display Name	IP Address	Streaming	RTMP Sever URL	Stream Name
<input type="checkbox"/>	1	GV-FER5700	192.168.3.73	1		
<input type="checkbox"/>	2	GV-FER5700	192.168.0.87	1		
<input type="checkbox"/>	3	GV-FD5700	192.168.6.88	1		
<input type="checkbox"/>	4	GV-MFD4700	192.168.5.221	1		
<input type="checkbox"/>	5	GV-BL2511	192.168.5.164	1		
<input type="checkbox"/>	6	GV-FE2301	192.168.7.62	1		

Items selected : 0/16

Save Reload

Live stream camera on Youtube !

Figure 5-50

4. Sign in with a valid YouTube account, scroll down to the **Encoder Setup** section from the **Stream now** page. Copy the **Server URL** and **Stream name/key** at the bottom.

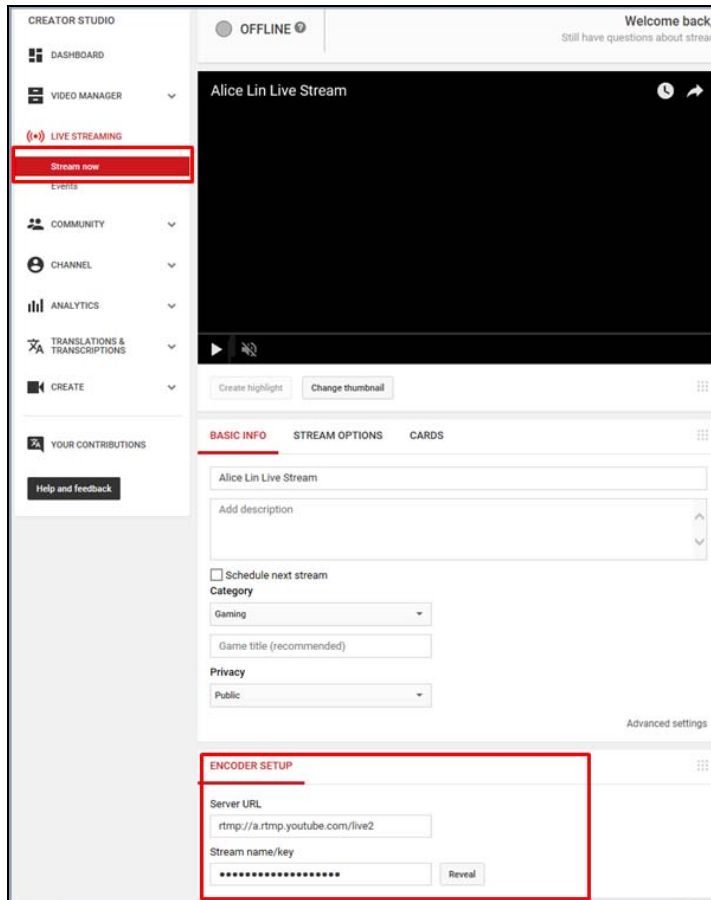

Figure 5-51

5. Select the desired camera and click **Edit**  .

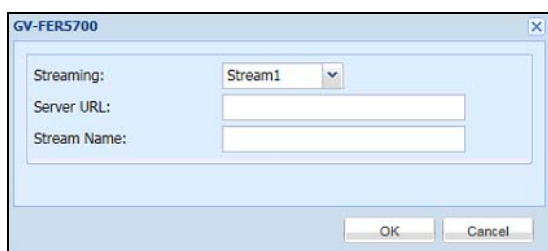

Figure 5-52

6. Select **Stream 1** or **Stream 2** to be live streamed on YouTube.
7. Paste the **Server URL** and **Stream Name** obtained from the setup page of YouTube and click **OK**.
8. Select **Enable** next to the camera to start live streaming of the camera's image.
9. Click **Save** and restart **Video Gateway** service on the Service page (Server > Service).

5.5.9 User Account

You can create up to 1000 User and Supervisor accounts to access GV-Recording Server and GV-Video Gateway. The Supervisor accounts have full access to GV-Recording Server and GV-Video Gateway, and you can set up different levels of access rights for the User accounts.

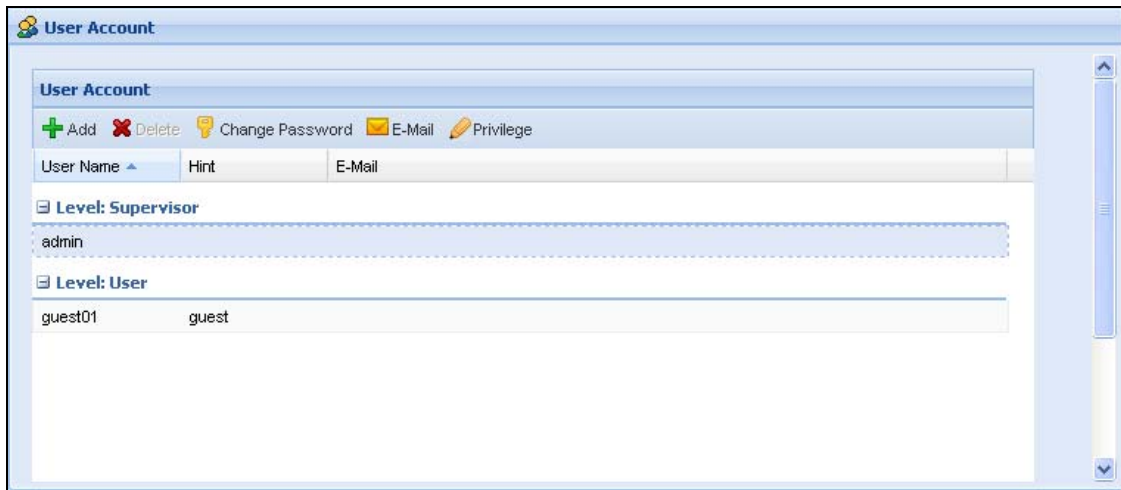



Figure 5-53

To create an account:

1. Click **Add** . This dialog box appears.

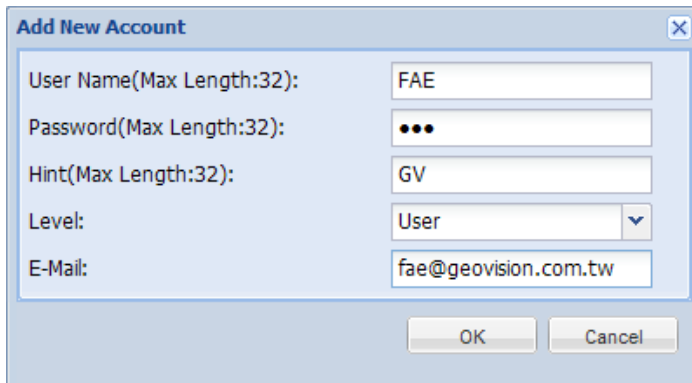
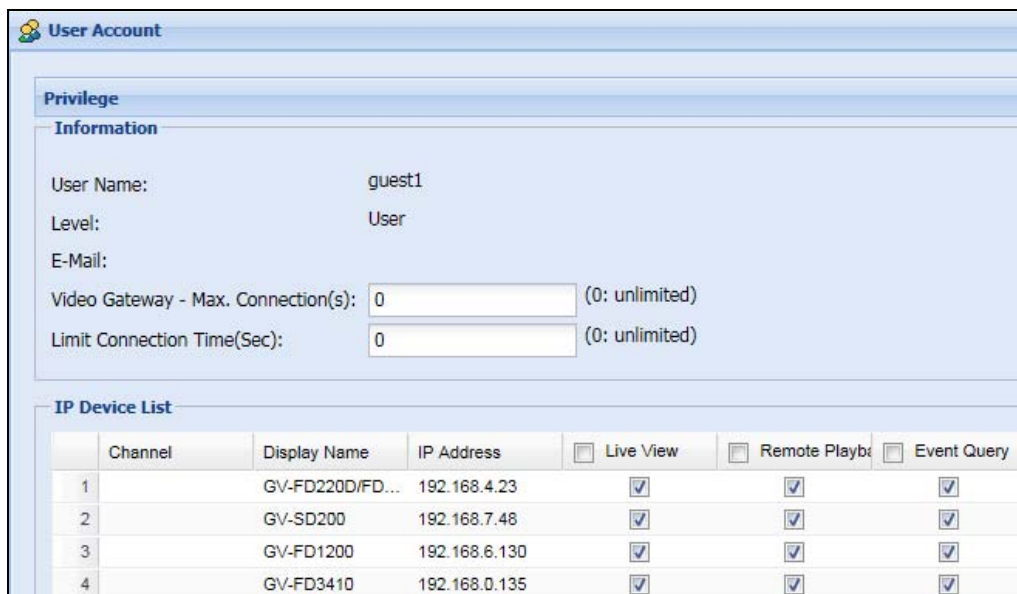

Figure 5-54

2. Type the **User Name**, **Password** and a password **Hint** for the account.
3. Use the **Level** drop-down list to select **Supervisor** or **User**.
4. Type an e-mail address for the account. When you forget the password, the password can be sent to your e-mail account using the Forget Password link in the login page.
5. Click **OK** to return to the User Account List. You can edit the account settings using the **Change Password** and **E-Mail** buttons.

To set access rights:

1. Select a user account and click the **Privilege** button . This dialog box appears.



	Channel	Display Name	IP Address	<input type="checkbox"/> Live View	<input type="checkbox"/> Remote Playback	<input type="checkbox"/> Event Query
1		GV-FD220D/FD...	192.168.4.23	<input checked="" type="checkbox"/>	<input checked="" type="checkbox"/>	<input checked="" type="checkbox"/>
2		GV-SD200	192.168.7.48	<input checked="" type="checkbox"/>	<input checked="" type="checkbox"/>	<input checked="" type="checkbox"/>
3		GV-FD1200	192.168.6.130	<input checked="" type="checkbox"/>	<input checked="" type="checkbox"/>	<input checked="" type="checkbox"/>
4		GV-FD3410	192.168.0.135	<input checked="" type="checkbox"/>	<input checked="" type="checkbox"/>	<input checked="" type="checkbox"/>

Figure 5-55

2. Specify the maximum number of simultaneous logins, including via remote connections, allowed by the user account in **Video Gateway – Max. Connection(s)**.
3. Specify the maximum time the user is allowed to access the GV-Recording Server, in seconds, per login in **Limit Connection Time**.
4. Under **IP Device List**, select or deselect to allow or restrict the account to accessing the **Live View**, **Remote Playback** and **Event Query** of the camera.
5. Click **Save**.

5.5.10 Advanced Query

Using **Advanced Query**, you can see the live view of the cameras within *Working Camera List*, as well as search for events to remotely play back their recordings. In addition, you can query for GV-Recording Server system logs and look up graphical charts for event analysis.

The Advanced Query interface is the same whether you log into GV-Recording Server using the administrator account or a client user account. For more details on Advanced Query, refer to *Chapter 6 User Mode*.

Chapter 6 User Mode

The GV-Recording Server administrator can create user accounts with different access rights to its Web interface. Refer to 5.5.9 *User Account* to see how to create user accounts for clients. After the client account is created, follow the steps below to access the Web interface in User Mode.

1. In the Location/Address field of Internet Explorer, type the IP address or the domain name of the GV-Recording Server.

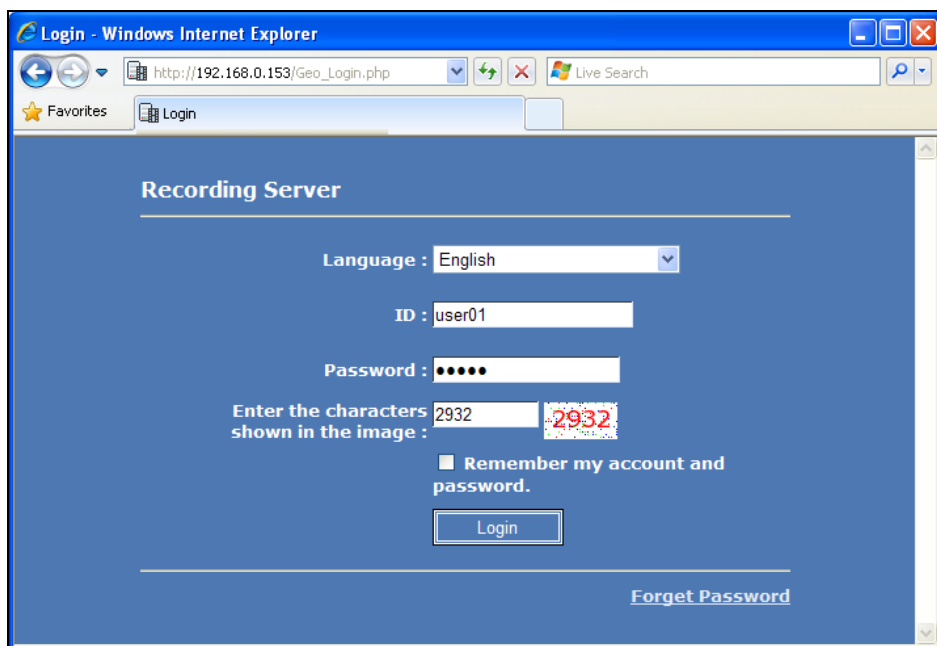

Figure 6-1

2. In the login page of the GV-Recording Server Web interface, type the **ID** and the **Password** of the client account.
3. Type the verification number shown in the image.
4. Click **Login**. The GV-Recording Server Advanced Query Web interface is now displayed.

Note: The GV-Recording Server supports several browsers to access its Web interface, including Internet Explorer, Firefox, Google Chrome and Safari. You can access single live view by using Firefox and Internet Explorer. Only Internet Explorer is supported for playing back recorded files.

6.1 Single Live View

In the left menu, expand **Live View** and select **One Channel** to display the Single Live View. Select from **Working Camera List** to switch between cameras.

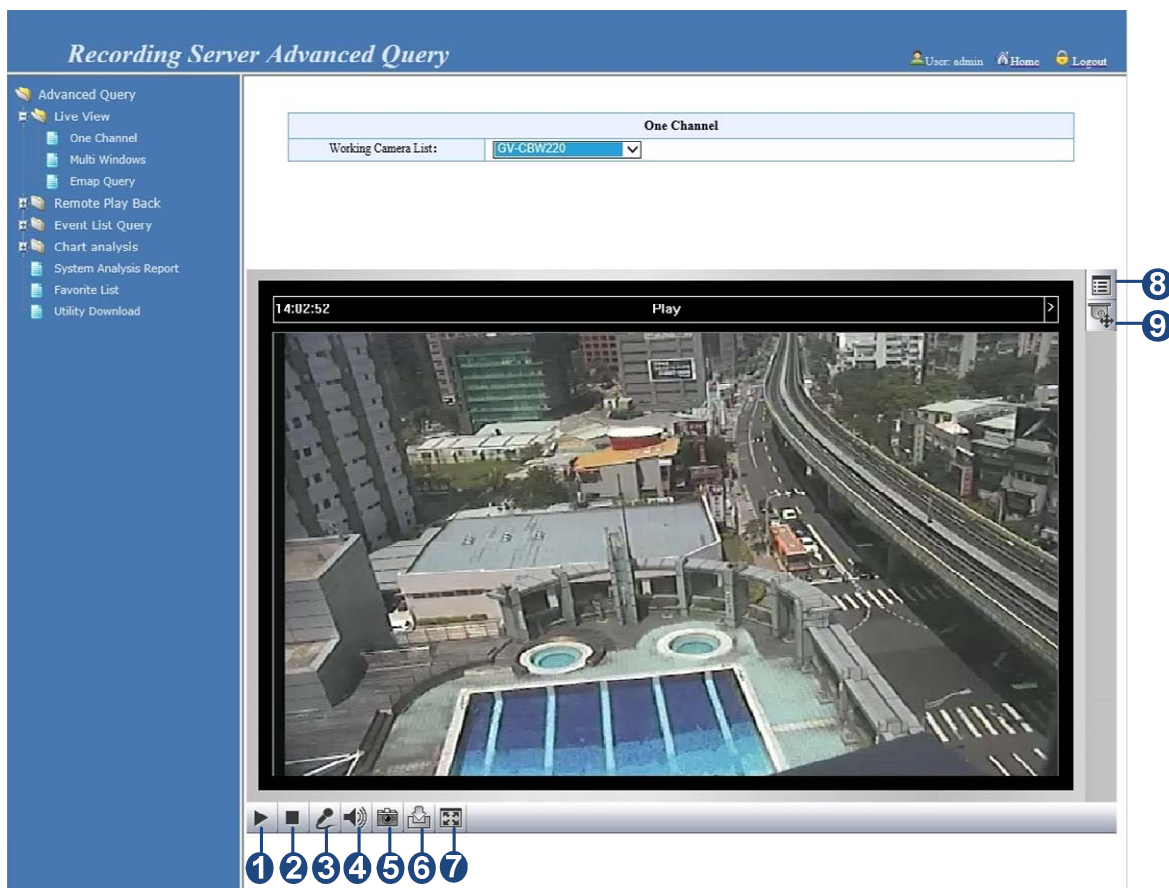

Figure 6-2

No.	Name	Description
1	Play	Plays live video.
2	Stop	Stops playing video.
3	Microphone	Talks to the surveillance area from the local computer.
4	Speaker	Listens to the audio around the camera.
5	Snapshot	Takes a snapshot of live video.
6	Download	Records live video to the local computer.
7	Full Screen	Switches to full screen view. Right-click the image to have these options: Snapshot, Resolution, PIP, PAP, Fisheye, IMV1 Panomorph (camera built-in fisheye dewarping function for certain models), GPS, Google Maps, Zoom In and Zoom Out .
8	Option	Select for the following functions: <ul style="list-style-type: none"> • Video and Audio Configuration: Set the frames kept in live stream buffer as well as enable/disable and adjust the volume of audio • Remote Config: Upgrade camera firmware using a firmware file

from the local PC

- **Show Camera Name:** Display the name of the camera on the live view
- **Image Enhance:** See 6.1.7 *Image Enhancement*

9 PTZ Control See 6.1.5 *PTZ Control* and 6.1.6 *Visual PTZ*

Note:

1. To listen to the audio, the **Audio** function (Figure 5-18) must be enabled on the GV-Recording Server in advance.
2. The two-way audio communication only works for GV-IP device connected through active mode.

6.1.1 Control Panel

To open the control panel of the Live View window, click the **Menu** button at the top of the viewer. You can access the following functions by using the left and right arrow buttons on the control panel.

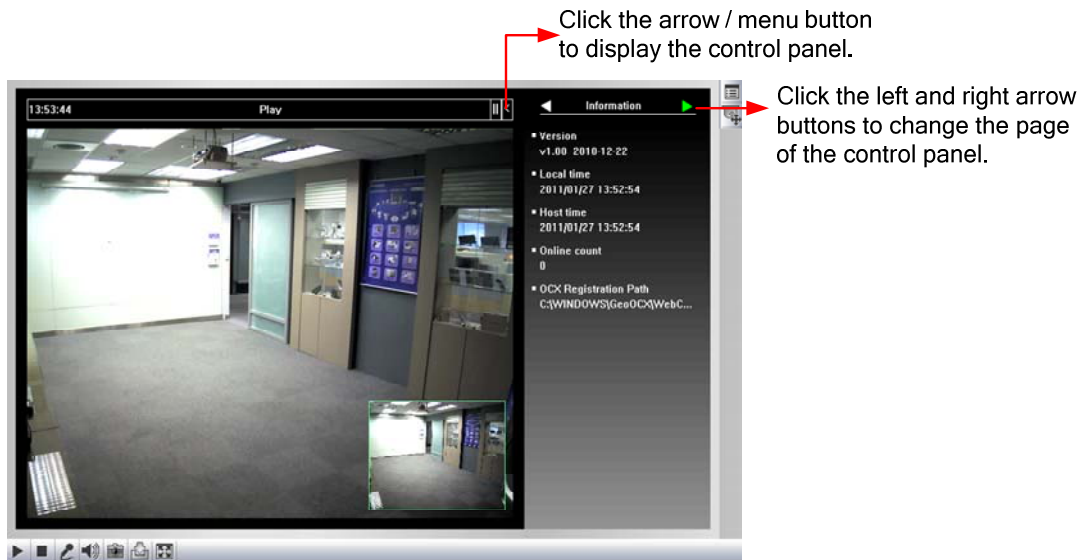

Figure 6-3

[Information] Displays the camera’s firmware version, time of the local PC, time of the camera, and the number of users currently accessing.

[Video] Displays the current video codec, resolution and data rate.

[Audio] Displays the audio data rates when the microphone and speaker devices are enabled.

[GPS] For details see 6.1.8 *GPS Tracking*.

[Camera Adjustment] Allows you to adjust the image quality.

6.1.2 Snapshot of a Live Video

To take a snapshot of the live video:

1. Click the **Snapshot** button (No. 5, Figure 6-2). The Save As dialog box appears.
2. Specify **Save in**, type the **File name**, and select **JPEG** or **BMP** as **Save as Type**. You may also choose whether to display the name and date stamps on the image.
3. Click the **Save** button to save the image on your local PC.

6.1.3 Video Recording

You can record the live video to your local computer.

1. Click the **Download** button (No. 6, Figure 6-2). The Save As dialog box appears.
2. Specify **Save in**, type the **File name**, and move the **Time Period** scroll bar to specify the maximum time length of each video clip recorded, from 1 to 5 minutes.
3. Click the **Save** button to start recording.
4. To stop recording, click the **Stop** button (No. 2, Figure 6-2).

6.1.4 Picture-in-Picture and Picture-and-Picture View

The full screen mode provides two types of close-up views: **Picture-in-Picture (PIP)** and **Picture-and Picture (PAP)**. The two views are useful in providing clear and detailed images of the surveillance area.

To access this feature:

- Click the **Full Screen** button (No. 7, Figure 6-2). Right-click the full screen to select **PIP** or **PAP**.
- Right-click the live view to select **PIP** or **PAP**.

Picture-in-Picture View

With the Picture in Picture (PIP) view, you can crop the video to get a close-up, or zoomed-in, view of the video.



Figure 6-4

1. Select **PIP**. An inset window appears.
2. Click the insert window. A navigation box appears.
3. Move the navigation box around in the inset window to have a close-up view of the selected area.
4. To adjust the navigation box size, move the cursor to any of the box corners, and enlarge or diminish the box.
5. To exit the PIP view, right-click the image and click **PIP** again.

Picture-and-Picture View

With the Picture and Picture (PAP) view, you can create a split video effect with multiple close-up views on the image. A total of 7 close-up views can be defined.



Figure 6-5

1. Select **PAP**. A row of three inset windows appears at the bottom.
2. Draw a navigation box on the image, and this selected area is immediately reflected in one inset window. Up to seven navigation boxes can be drawn on the image.
3. To adjust a navigation box size, move the cursor to any of the box corners, and enlarge or diminish the box.
4. To move a navigation box to another area on the image, click and drag it to that area.
5. To change the frame color of the navigation box or hide the box, right-click on it, select **Mega Pixel Setting** and choose one of the following:
 - **Display Focus Area of PAP Mode:** Displays or hides the navigation boxes.
 - **Set Color of Focus Area:** Changes the color of the box frames.
6. To delete a navigation box, right-click the desired box, select **Focus Area of PAP Mode** and click **Delete**.
7. To exit the PAP view, right-click the image and click **PAP** again.

6.1.5 PTZ Control

To open the PTZ control panel, click the **PTZ Control** button (No. 8, Figure 6-2) and select **PTZ Control Panel**. Different PTZ devices have different functions, so the features included under **Option** may vary.

This feature is only available when the connected IP camera has the PTZ function.

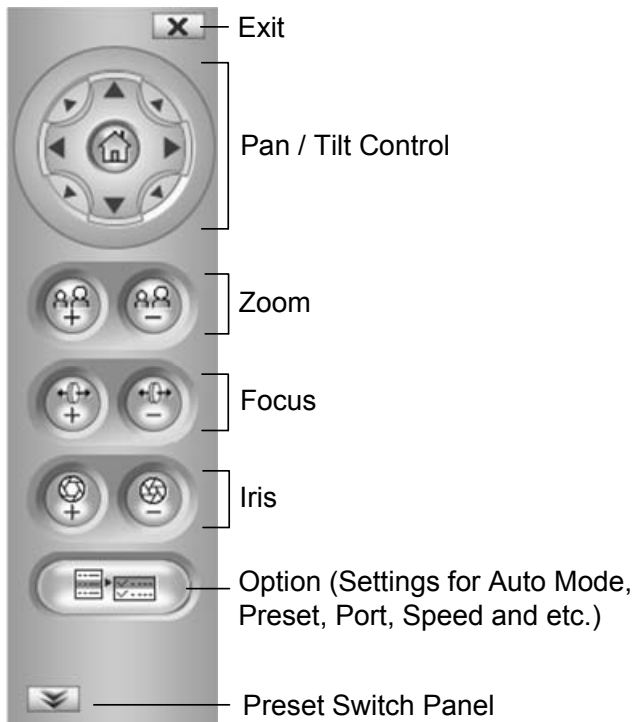

Figure 6-6

6.1.6 Visual PTZ

In addition to the PTZ control panel, you can display a visual PTZ control panel on the image. This feature is only available when the connected IP camera has the PTZ function.



Figure 6-7

- To access this feature, click the **PTZ Control** button (No. 8, Figure 6-2) and select **Visual PTZ**.
- To change the panel settings, click the green **PTZ** button on the upper-left corner to access the following:

[PTZ Control Type]

 - **Fixed Direction Move:** In this mode, the dome view can only be moved in eight directions (north, south, east, west, northeast, northwest, southeast and southwest). To move the camera view, click, hold and move the cursor along the dotted red line away from the panel. The round panel appears whenever the cursor is placed on the live view.
 - **Random Move:** In this mode, you can move the camera view to any direction. Click any place on the live view for the panel to appear, and right-click for the panel to hide. To move the camera view, click and drag toward a desired direction. The further away the cursor, the faster the movement of camera view.
 - **Center Move:** In this mode, you can zoom in and out using the mouse scroll or by drawing a block directly on the live view. The **Center Move** mode is only for GV-SD220.

[Configure]

- **Set Color:** Changes the color of the panel. Three kinds of colors are available: **Red**, **Green** and **Blue**.
- **Transparent Degree:** Adjusts the transparency level of the panel, with 10 levels ranging from 10% (fully transparent) to 100% (fully opaque).

6.1.7 Image Enhancement

To enhance the image quality of live video, click the **Options** button (No. 8, Figure 6-2), and select **Image Enhance**. This dialog box appears.

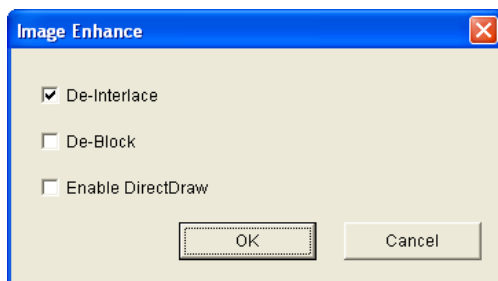

Figure 6-8

- **De-Interlace:** Converts the interlaced video into non-interlaced video.
- **De-Block:** Removes the block-like artifacts from low-quality and highly compressed video.
- **Enable DirectDraw:** Activates the DirectDraw function.

6.1.8 GPS Tracking

The GPS page allows you to see the location of the connected IP device on Google maps. The GPS location can only be displayed when the connected IP device is installed with the GPS equipment with the GPS function enabled.

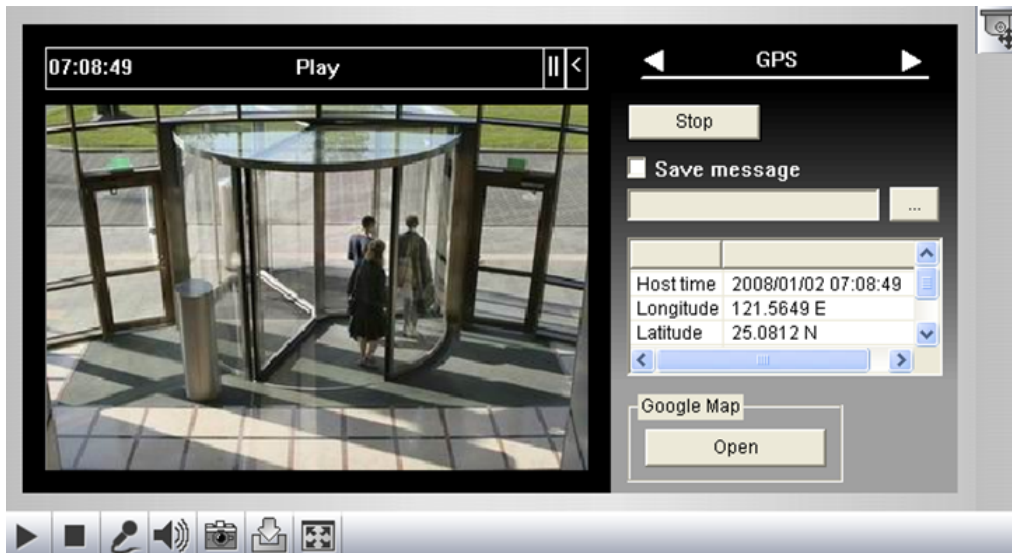

Figure 6-9

To track the location of the connected IP device:

1. Click **Menu** > **GPS** to access the GPS setting page.
2. Click **Start** to activate GPS tracking. The longitude, latitude and host name of the connected IP device is displayed.
3. To save the location information to your local computer, select **Save message** and click [...] to assign the storage path.
4. Click **Open**. A dialog box appears.
5. Enter the **Google Maps API key**. Refer to 5.5.1 *E-map* to see how to obtain a Google Maps API Key.

- Click **OK**. A warning message appears.

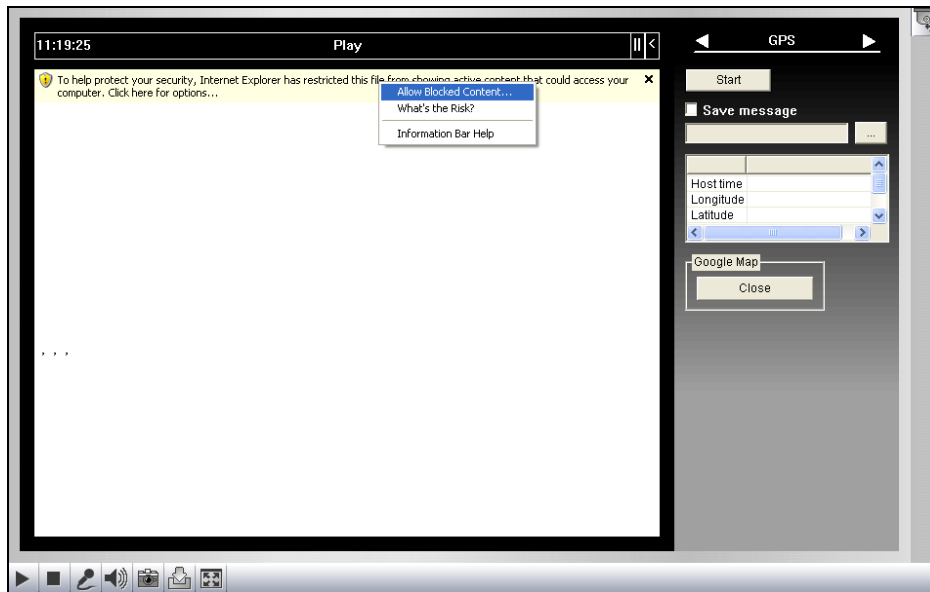

Figure 6-10

- Right-click the warning message and select **Allow Blocked Content**. The map is displayed. The  icon indicates the location of the device. You can alternate between map formats using the options at the upper-right corner, e.g. Satellite and Hybrid.



Figure 6-11

6.2 Multi-Channel Live View

In the left menu, expand **Live View** and select **Multi Windows** to display up to 16 channels of live images.

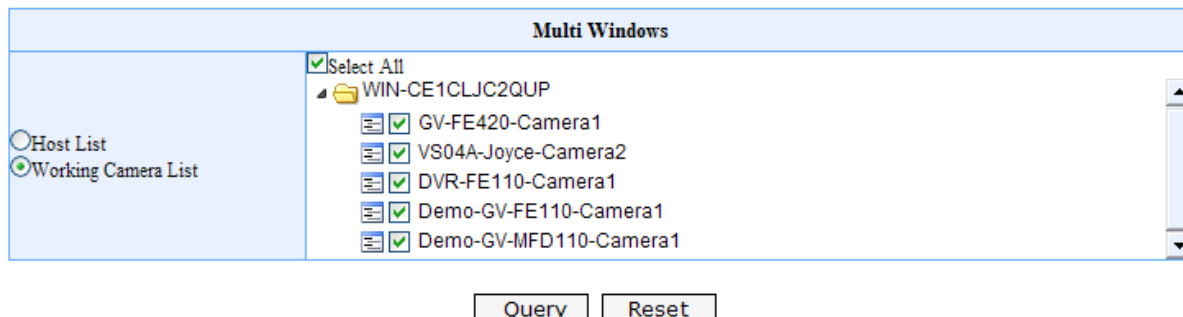

Figure 6-12

1. Select **Working Camera List** or **Host List** to list all cameras by channel or IP device.
2. Double-click server name and select the cameras, or select **Select All**.
3. Click **Query** to access the live view.

Note: Only Internet Explorer browser is supported for multi-channel live view.

6.3 Emap Query

In the left menu, expand **Live View** and select **Emap Query** to see the cameras' locations on Google Maps, view its live images and/or the Google Street View of the locations.

Note: This page is only available when at least one camera is added to the E-map, see [5.5.1 E-map](#).

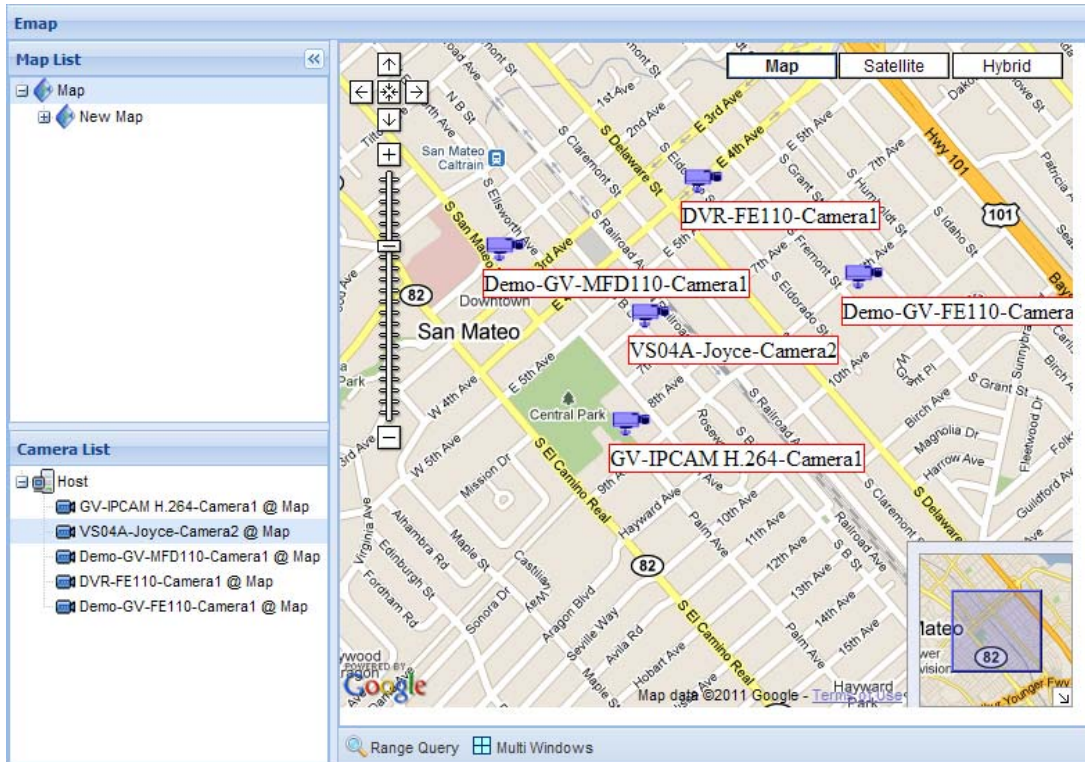

Figure 6-13

1. In **Camera List**, double-click a camera to locate the camera on Google Maps.
2. Right-click the camera icon and click **Live View** to see its live image or click **Street View** to see the Google Street View of its location.
3. At the bottom of the page, you can click **Range Query** and a circular area will be highlighted on the map. You can adjust the location and size of the area and click **Multi Windows** to see the live view of all cameras enclosed within.

6.4 Remote Playback

There are two ways to look up and play back recordings under **Remote Playback**:

- **Event List Query**: Search for recordings within a specified time range.
- **Preview Query**: Access recordings of each device by clicking on its snapshot.

6.4.1 Event List Query

In the left menu, expand **Remote Playback** and select **Event List Query** to search for and play back recordings within a specified time period.

The screenshot displays the 'Remote Play Back' interface. At the top, there are radio buttons for 'Host List' (selected) and 'Working Camera List'. Below this, a tree view shows 'TestPC-PC' selected. An 'Event Type' dropdown is set to 'Select All'. The 'Time' section has two options: 'Quick' (selected) with a date of '2013-11-29' and a time of '17:00:00', and 'Range' with a date range from '2013-11-28 00:00:00' to '2013-11-29 23:59:59'. Below the time section are buttons for 'Query', 'Reset', and 'Add Favorite'. The 'Query Result List' section shows a table with columns: Device N..., Host, Camera, Event Type, RemoteStart Time, RemoteEnd Time, Elapsed..., File Siz..., DST, Previ..., and VIDEO CLIP. The table contains four rows of results, each with a 'View' link under the VIDEO CLIP column.

	Device N...	Host	Camera	Event Type	RemoteStart Time	RemoteEnd Time	Elapsed...	File Siz...	DST	Previ...	VIDEO CLIP
1	TestPC-PC	GV-BX130...	Camera1	Motion	2013-11-29 14:4..	2013-11-29 14:4..	00:00:04	0.399	No		View
2	TestPC-PC	GV-BX130...	Camera1	Motion	2013-11-29 14:4..	2013-11-29 14:4..	00:00:38	2.745	No		View
3	TestPC-PC	GV-BX130...	Camera1	Motion	2013-11-29 14:5..	2013-11-29 14:5..	00:01:01	5.146	No		View
4	TestPC-PC	GV-BX130...	Camera1	Motion	2013-11-29 14:5..	2013-11-29 14:5..	00:00:12	1.053	No		View

Figure 6-14

1. Select **Working Camera List** or **Host List** to list all cameras by channel or IP device.
2. Double-click the server name and select the cameras, or select **Select All**.
3. Optionally select an **Event Type** from its drop-down list to search for particular events.
4. In the **Time** section, select **Quick** to search for recordings before and after that time or select **Range** to specify a time period directly.
5. Click **Query** to see the search results.
6. To see a snapshot of the video, click the **Preview** button . To see the recorded video, click **View** under Video Clip.

You can click **Add Favorite** to save the search criteria into the **Favorite List** for future use. You can also export the search results in word format and excel format by clicking **Export Word** or **Export Csv**.

Note: Only Internet Explorer browser is supported for Remote Playback function.

6.4.2 Preview Query

In the left menu, expand **Remote Playback** and select **Preview Query** to see snapshots of the most recent video file recorded by the cameras. Click the snapshot to access the camera live view and search for recordings before and/or after a specified time. This preview function allows you to quickly identify the camera you want to access.



Figure 6-15

1. Select a camera by clicking the snapshot preview. This dialog box appears.

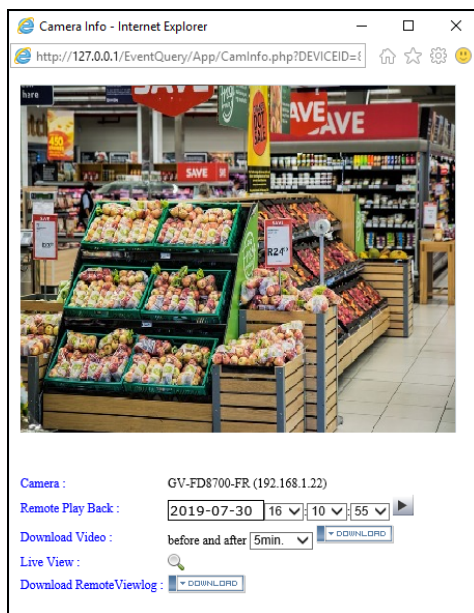



Figure 6-16

2. To play back recordings from a specific time point, select the date and time next to **Remote Playback** and click the **Playback** button .
3. To download the recordings before and after the specified time point, select a time length of 5 minutes, 10 minutes or 20 minutes and click **Download**.
4. To access the camera live view, click the **Live View** button .

You can also download the Remote ViewLog program to access recorded files. Refer to 7.5 *Connecting with Remote ViewLog* for details on how to set up Remote ViewLog.

6.5 Composite Information Query

Using the **Composite Information Query** under **Event List Query**, you can search for and play back camera events during the time period specified, see the location of the camera on E-map, as well as watch its live view.

Note: This page is only available when at least one camera is added to the E-map.

The screenshot displays the 'Composite Information Query' interface. At the top, there are options for 'Host List' and 'Working Camera List' (selected), with a folder icon for 'Test177-PC'. The 'Event Type' is set to 'Select All'. The 'Time' section includes a 'Quick' search for '2011-2-1 15:00:00' and a 'Range' search from '2011-2-2 00:00:00' to '2011-3-2 23:59:59'. Below these are 'Query' and 'Reset' buttons.

The 'Remote Playback List' window shows a table of search results:

Query Result List			
	Camera	Event Type	RemoteSta
1	DVR-FE110-Camera1	Round the Clock	2011-02-
2	VS04A-Joyce-Camera2	Round the Clock	2011-02-
3	GV-IPCAM H.264-Camera1	Round the Clock	2011-02-
4	DVR-FE110-Camera1	Round the Clock	2011-02-
5	VS04A-Joyce-Camera2	Round the Clock	2011-02-
6	GV-IPCAM H.264-Camera1	Round the Clock	2011-02-
7	DVR-FE110-Camera1	Round the Clock	2011-02-
8	VS04A-Joyce-Camera2	Round the Clock	2011-02-
9	GV-IPCAM H.264-Camera1	Round the Clock	2011-02-
10	DVR-FE110-Camera1	Round the Clock	2011-02-

The 'Camera In Map' window shows a Google Map of San Mateo with several camera icons overlaid on the map. The 'Remote Playback' window shows a live video feed of a glass-enclosed turnstile with people walking through it. The playback controls at the bottom show a timestamp of '2/24/2011 18:32:56.968' and standard video playback buttons.

Figure 6-17

1. Follow Step 1 ~ 4 in 6.4.1 Event List Query.
2. Click **Query** to see the search results. To see the live view of a camera, select the camera from the map and click the play button.

6.6 System Log Query

Using **System Log Query**, you can search for system events of GV-Recording Server, such as camera connection, HTTP server activation, video recycling and USB Protection Key status etc. Select **Event List Query > System Log Query**.

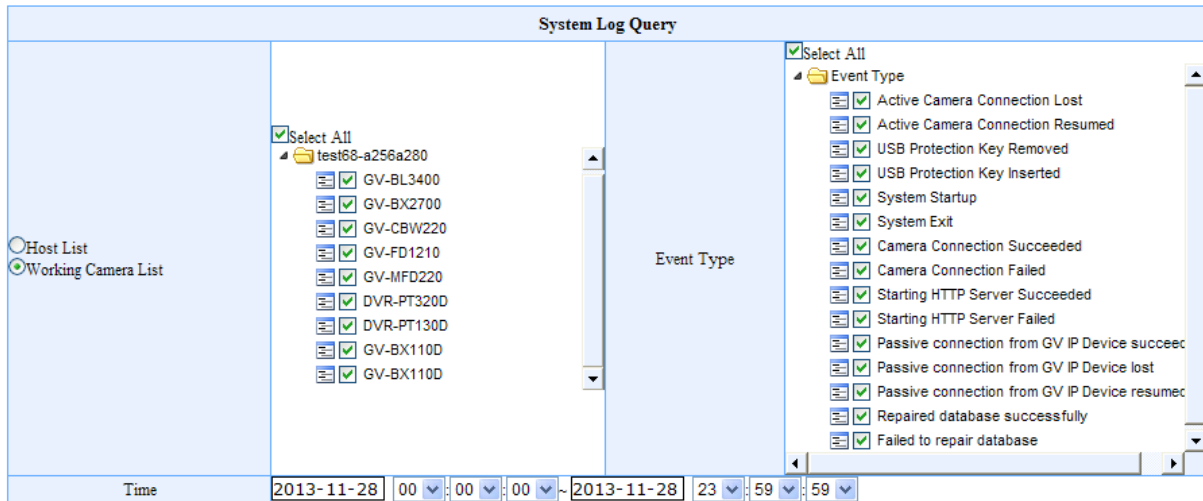
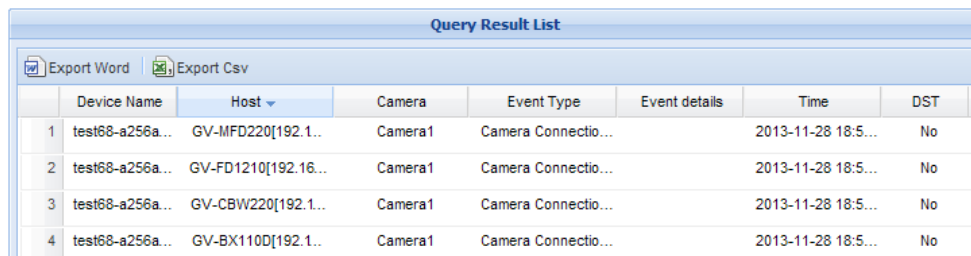
	Device Name	Host	Camera	Event Type	Event details	Time	DST
1	test68-a256a...	GV-MFD220[192.1...	Camera1	Camera Connectio...		2013-11-28 18:5...	No
2	test68-a256a...	GV-FD1210[192.16...	Camera1	Camera Connectio...		2013-11-28 18:5...	No
3	test68-a256a...	GV-CBW220[192.1...	Camera1	Camera Connectio...		2013-11-28 18:5...	No
4	test68-a256a...	GV-BX110D[192.1...	Camera1	Camera Connectio...		2013-11-28 18:5...	No

Figure 6-18

1. Select **Working Camera List** or **Host List** to list all cameras by channel or IP device.
2. Double-click the server name and select the cameras, or select **Select All**.
3. Optionally expand **Event Type** to select and search for particular type(s) of events.
4. In the **Time** section, specify for a period of time.
5. Click **Query** to see the search results.

You can click the **Add Favorite** button to save the search criteria to the **Favorite List** for future use. You can also export the search results in word format and excel format by clicking **Export Word** or **Export Csv**.

6.7 Behavior Log Query

Using the Behavior Log Event Query, you can search for events performed by the specified Supervisor or Client account(s), such as adding a host, adding a user, modifying a port, previewing video images and etc. Select **Event List Query > Behavior Log Query**.

The screenshot shows the 'Behavior Log Query' interface. It includes fields for Host (TestPC-PC), Behavior Type (Behavior Type), User Name (admin), and Time (2013-11-29 00:00:00 to 2013-11-29 23:59:59). Below these fields are buttons for 'Query', 'Reset', and 'Add Favorite'. The 'Query Result List' table below shows the following data:

	Device Name	Host	Camera	User Name	Behavior Type	Time	DST
1	TestPC-PC			admin	Reload Camera List	2013-11-29 14:47:12	No
2	TestPC-PC	GV-VS02A[192.168.0.38]	Camera1	admin	Modify Video Clip Time	2013-11-29 14:47:28	No
3	TestPC-PC	GV-VS02A[192.168.0.38]	Camera1	admin	Modify Recording Setti..	2013-11-29 14:47:28	No
4	TestPC-PC	GV-VS02A[192.168.0.38]	Camera2	admin	Modify Video Clip Time	2013-11-29 14:47:28	No
5	TestPC-PC	GV-VS02A[192.168.0.38]	Camera2	admin	Modify Recording Setti..	2013-11-29 14:47:28	No

Figure 6-19

1. In the **Host** section, click the server name and select the cameras, or select **Select All**.
2. In the **User Name** section, type the Supervisor's or Client's name. Leave the field blank to search for all users that have accessed the GV-Recording Server.
3. Optionally expand **Behavior Type** to select particular types of activities.
4. In the **Time** section, specify a period of time.
5. In the **Working Camera / Host List** section, select **Working Camera List** to search for connecting hosts, or **Host List** to include the disconnected hosts, or click **Select All**.
6. Click **Query** to see the search results.

You can click the **Add Favorite** button to save the search criteria to the **Favorite List** for future use. You can also export the search results in word format and excel format by clicking **Export Word** or **Export Csv**.

6.8 Login / Logout Query

Using the Login and Logout Query, you can search for login and logout records of the Supervisor and Clients. Select **Event List Query > Login / Logout Query**.

Login / Logout Query

Device Name	<input checked="" type="checkbox"/> Select All <input checked="" type="checkbox"/> TestPC-PC	User Name	admin
Login / Logout	Select All		
Time	2013-11-29	00	00
Status	Select All	Mode	Select All
DST	Select All		

Query Result List

	Device Name	User Name	Login / Logout	Time	Status	Mode	NOTE	DST
1	TestPC-PC	admin	Login	2013-11-29 14:4...	Success	Local	127.0.0.1	No
2	TestPC-PC	admin	Login	2013-11-29 17:1...	Success	Local	192.168.5.21	No
3	TestPC-PC	admin	Login	2013-11-29 17:1...	Success	Local	192.168.5.106	No
4	TestPC-PC	admin	Login	2013-11-29 17:2...	Success	Video Gateway	(192.168.0.136)	No

Figure 6-20

1. Under **Device Name**, click the server name to select individual cameras, or **Select All**.
2. In the **User Name** section, type the Supervisor's or Client's name. Leave the field blank to search for all users that have accessed the GV-Recording Server.
3. Optionally select to search for a particular type of event under **Login / Logout**.
4. In the **Time** section, specify a period of time.
5. In the **Status** section, optionally select login **Fail** or **Success**.
6. In the **Mode** section, select **Local**, **Video Gateway** or **All** for local, remote login or all types of logins, respectively.
7. In the **DST** section, select **Select All** to search for all events including DST (Daylight Saving Time) events, **Y** for only DST events or **N** to exclude DST events.
8. Click **Query** to see the search results.

You can click the **Add Favorite** button to save the search criteria to the Favorite List in the left menu for future use. You can also export the search results in word format and excel format by clicking **Export Word** or **Export Csv**.

6.9 Stat Chart

Using the Stat Chart, you can see the following types of data analysis presented in three types of graph: bar, pie and line graph.

- **Stat of System Events:** Shows event counts of each type of system event.
- **Stat of Event File Size:** Shows the total file size of events recorded under each recording policy.
- **Stat of Recording Events:** Shows event counts for events recorded under each recording policy.
- **Stat of Event File Size by Hour:** Shows the file size of the recordings by hour, distinguished by the cameras selected, on a specified date in the form of a graph.

To search for Stat of System Events, Stat of Event File Size, or Stat of Recording Events, follow the steps below:

Stat of System Events					
<input type="radio"/> Host List	<input checked="" type="checkbox"/> Select All			Event Type	Select All
<input checked="" type="radio"/> Working Camera List	DESKTOP-74ASKLR				
Time	2019-10-09	00	00	00	2019-10-09 23:59:59
Graph Type	<input checked="" type="radio"/> Bar Graph <input type="radio"/> Pie Graph <input type="radio"/> Line Graph				

Figure 6-21

1. Select **Working Camera List** or **Host List** to list all cameras by channel or IP device.
2. Click the server name and select the desired IP devices, or select **Select All**.
3. In the **Event Type** section, select the desired type of event or **Select All**.
4. In the **Time** section, specify a period.
5. Select a type of graph under **Graph Type**.
6. For **Stat of Event File Size by Hour**, specify a desired date in the **Date** section.

Stat of Event File Size by Hour					
<input type="radio"/> Host List	<input checked="" type="checkbox"/> Select All			Event Type	Select All
<input checked="" type="radio"/> Working Camera List	DESKTOP-74ASKLR				
Graph Type	<input checked="" type="radio"/> Bar Graph <input type="radio"/> Pie Graph <input type="radio"/> Line Graph				
Date	2019	Year	10	Month	9

Figure 6-22

7. Click **Query** to display search results.

6.10 System Analysis Report

Using the System Analysis Report, you can see the following types of data analysis presented in a PDF file.

- **Recording Summary:** Shows the total recording size and the total counts of connection lost on the specified dates.
- **Recording Information of Disk:** Shows the recorded date, file size and write speed of each disk drive on the specified dates.
- **Disk Space:** Estimates the keep days for the recorded files according to the average recording speed and the total disk space on the specified dates.
- **Recording Size of Hour:** Shows the total file size recorded per hour, and displays the results in a bar graph on the specified dates.
- **Recording Information of Camera:** Shows the number of recordings and their total file size for each IP address connected on the specified dates.
- **Statistics of Connection Lost:** Shows the disconnection records for the cameras on the specified dates.
- **Camera Information:** Shows the camera name and their IP addresses connected on the specified dates.
- **Statistics of Event:** Shows all event types and their event counts on the specified dates.

To convert the data analysis to a PDF file, follow the steps below.

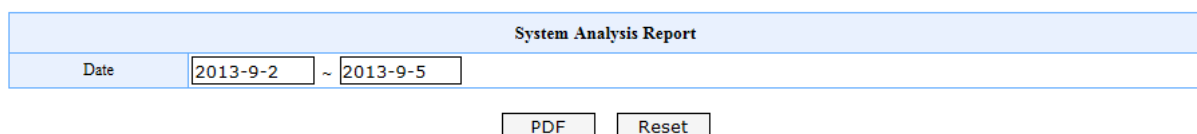

System Analysis Report	
Date	2013-9-2 ~ 2013-9-5

Figure 6-23

1. Select **System Analysis Report** from the left menu under **Stat Chart**.
2. Specify a time period for the data to be exported.
3. Click the **PDF** button to create the PDF file.

Chapter 7 Connections with Clients

The GV-Recording Server can simultaneously transmit up to 600 channels to clients. You can establish connection with GV-DVR / NVR, MultiView, Multicast, GV-VMS, Remote ViewLog, GV-Control Center, GV-Mobile Server and GV-Edge Recording Manager.

7.1 Connecting with GV-DVR / NVR

You need to configure the GV-DVR / NVR to access video streaming from the GV-Recording Server. You can download and install the GV-DVR / NVR from [GeoVision's website](#).

1. On the main screen of GV-DVR / NVR, click the **Configure** button, select **System Configure**, select **Camera Install** and select **IP Camera Install**. This dialog box appears.

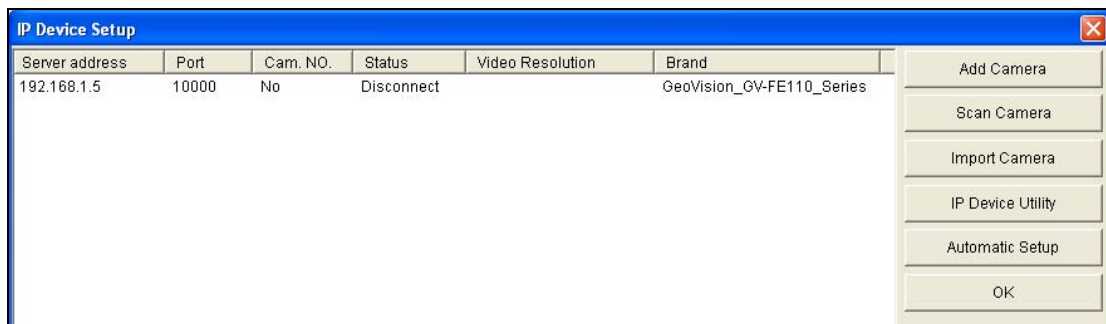

Figure 7-1

2. Click the **Add Camera** button. This dialog box appears.

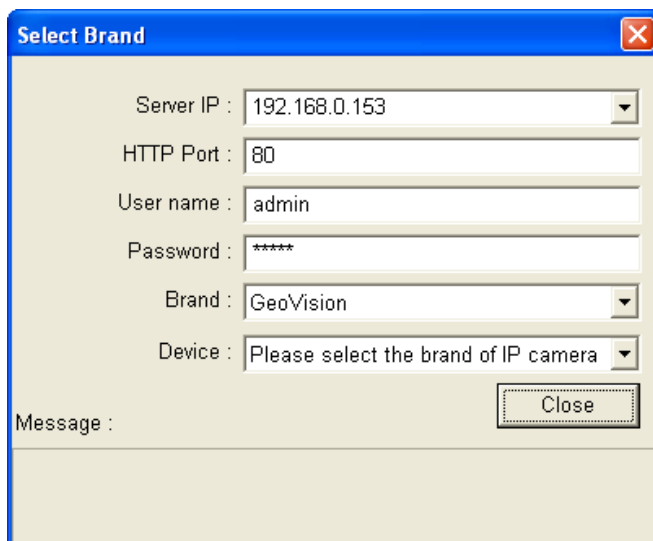

Figure 7-2

3. Type the IP address or domain name of the GV-Recording Server. Keep the default HTTP port of 80 or change to match that of the GV-Recording Server. Type the client's username and password created on the GV-Recording Server. Select **GV-Video Gateway / GV-Recording Server** from the Device drop-down list. This dialog box appears.

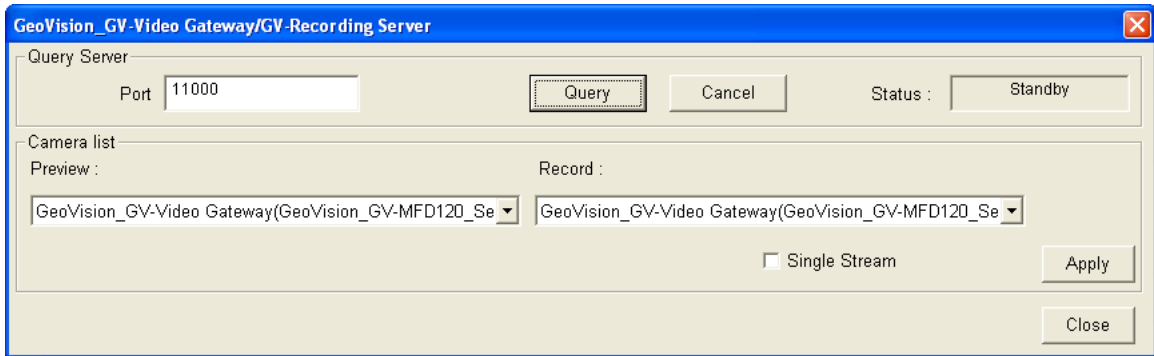

Figure 7-3

4. Keep the default communication port of GV-Recording Server as 11000, or modify the value to match the TCP/IP port on the GV-Recording Server (Figure 5-29). Click the **Query** button to connect to the GV-Recording Server. Once connected, the camera options will be displayed in the Preview and Record drop-down lists.
5. Select one camera to be connected. The selections in the Preview and Record drop-down lists will be the same.
6. Click **Apply**. The IP camera is added to the list.
7. To add another IP camera from the GV-Recording Server, click the **Add** button and follow steps 2 to 6. The number of IP cameras you can add depends on your GV-DVR's / NVR's capacity.
8. Click the listed camera, and select **Display Position** to map the IP camera to any channel on the GV-DVR / NVR. After the mapping is completed, the Status column will display "Connected".

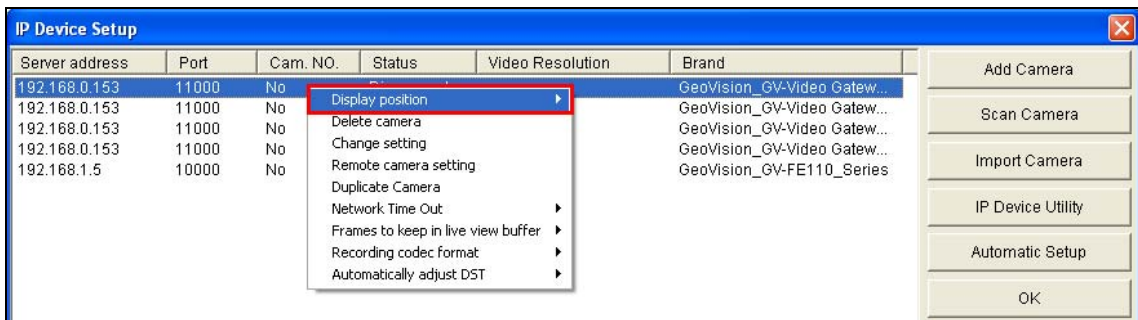

Figure 7-4

9. To listen to live audio from the IP camera, click the **Configure** button, select **AV Setting > Audio Settings > Wave Out**.

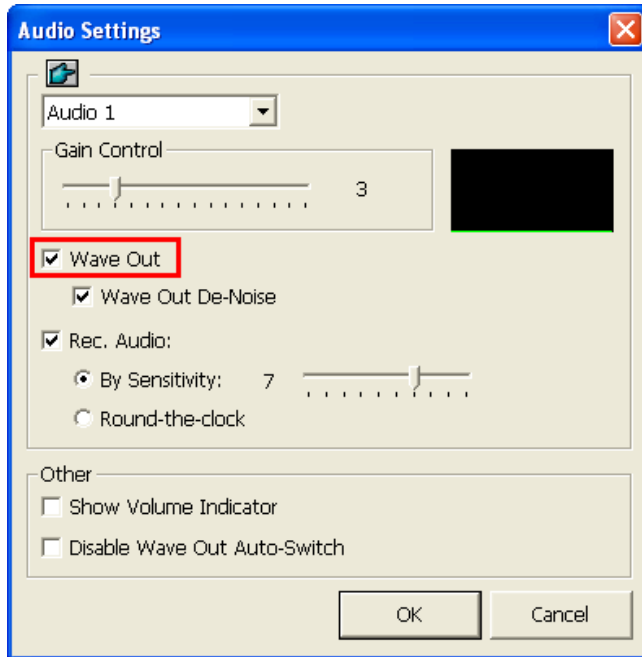

Figure 7-5

10. Click **OK** to exit all open dialog boxes. The IP camera from the GV-Recording Server is now displayed at the specified channel.
11. To talk to the surveillance area of the IP camera, right-click its mapped channel, select **Camera x** and select **Talk Back Toggle**.

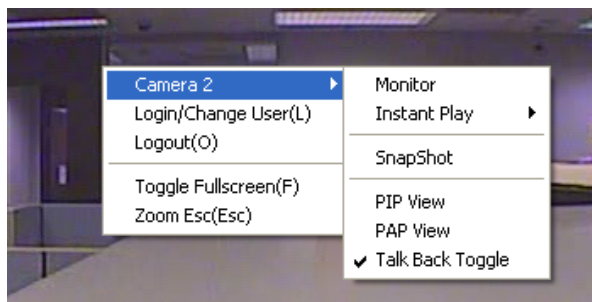

Figure 7-6

For details on GV-DVR / NVR, see *GV-DVR User's Manual* from [GeoVision's website](#).

7.2 Connecting with Multi View

You can find the Multi View from [GeoVision's website](#). Click **2. Install GeoVision Primary Applications** to access the installation program.

After installing the program, you need to log in the Multi View to access video streaming from the GV-Recording Server.

1. In the login dialog box, click the **Edit** button. This dialog box appears.

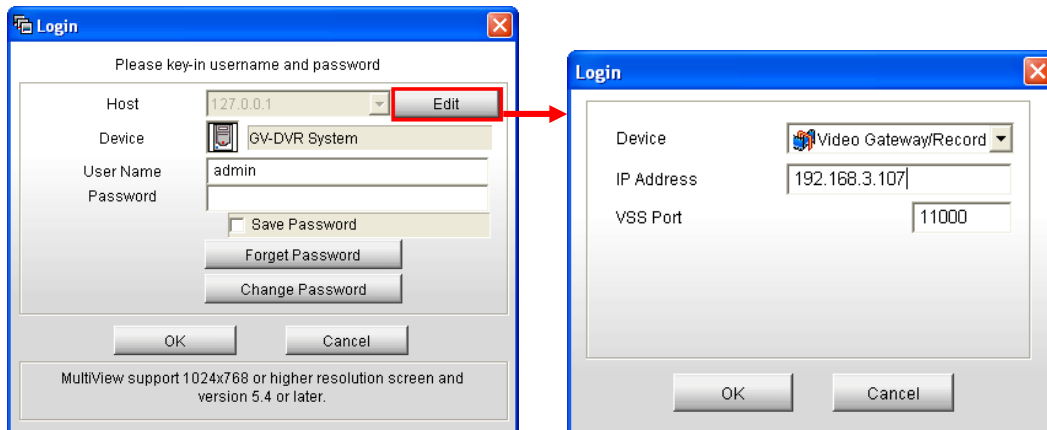

Figure 7-7

2. Select **Video Gateway / Recording Server** from the Device drop-down list.
3. Type IP address or domain name of the GV-Recording Server.
4. Keep the default VSS Port as 11000; otherwise modify it to match the TCP/IP port on the GV-Recording Server (Figure 5-29).
5. Click **OK** to return to the login page.

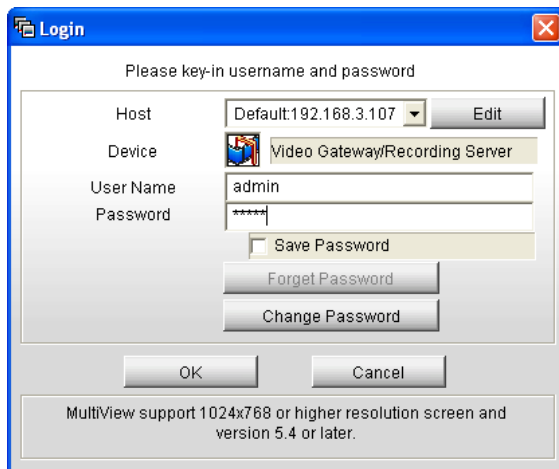

Figure 7-8

6. Type the client's username and password created on the GV-Recording Server.
7. Click **OK** to login.

8. The GV-Recording Server created on the Host list will be listed. Drag and drop its IP cameras to the desired channels on the Multi View.

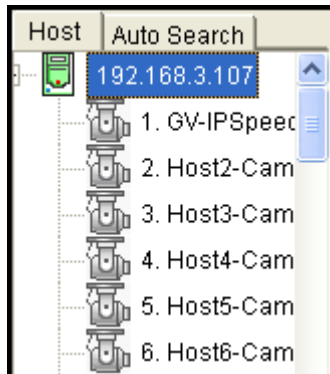

Figure 7-9

For details on the Multi View functions, see “Multi View Viewer”, Chapter 8 Remote Viewing, *GV-DVR User’s Manual* from [GeoVision’s website](#).

7.3 Connecting with Multicast

The Multicast view allows you to receive video and audio streams from a designated multicast IP address. You will need to first enable the multicast function as described in 5.3.5 *Video Gateway*.

You can find the Multicast from [GeoVision's website](#). Click **2. Install GeoVision Primary Applications** to access the installation program.

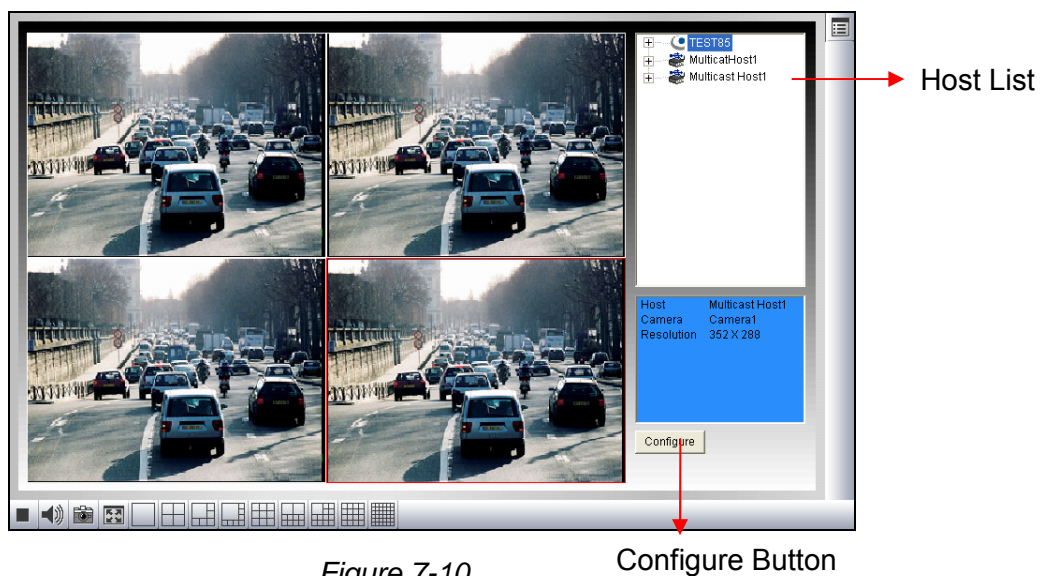

Figure 7-10

Configure Button



1. The host(s) in the multicast group is displayed automatically on the host list. If you cannot see any host displayed, click the **Configure** button, select **General Setup**, select **Multicast** and ensure the relevant IP address, port number and network card are correctly configured.
2. Expand the Host folder and drag the desired cameras to the screen for display. If the host has already set a password, you will be promoted to enter it at this step.
3. To receive audio broadcasting, first ensure a speaker is properly installed on the local computer. Then click the **Configure** button, select **General Setup**, select **Receive broadcast audio**, and ensure the broadcast IP address and port number are correctly configured.
4. To save the current settings of screen division and camera display for future use, click the **Configure** button, select **Video List Setup**, and select **Export**. You can also select **Import** to apply the pre-defined settings.

Note: Using Multicast, you can only connect to GV-Recording Server under LAN.

7.4 Connecting with GV-VMS

To set up the cameras from the GV-Recording Server on the GV-VMS, follow these steps:

You can download and install GV-VMS from the [GeoVision's website](#).

1. To access the IP Device Setup page, click **Home** , select **Toolbar** , click **Configure**  and select **Camera Install**.

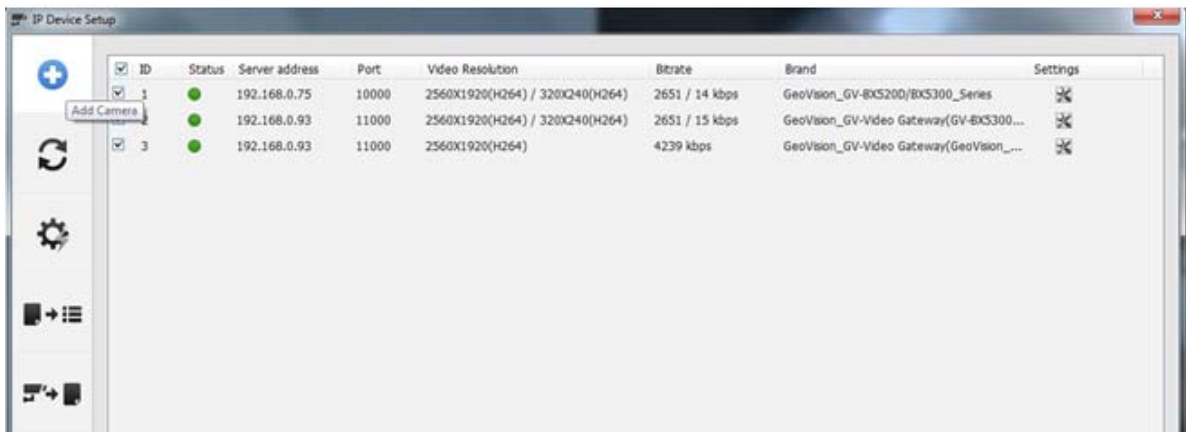

Figure 7-11

2. Click **Add Camera** . This dialog box appears.

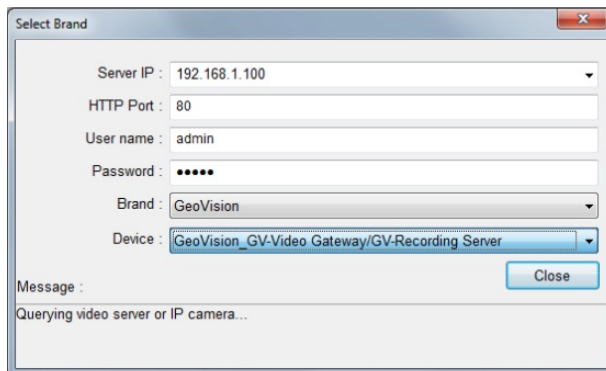

Figure 7-12

3. Type the IP address or domain name of the GV-Recording Server. Keep the default HTTP port of 80 or change to match that of the GV-Recording Server. Type the client's username and password created on the GV-Recording Server. Select **GV-Video Gateway / GV-Recording Server** from the Device drop-down list. This dialog box appears.

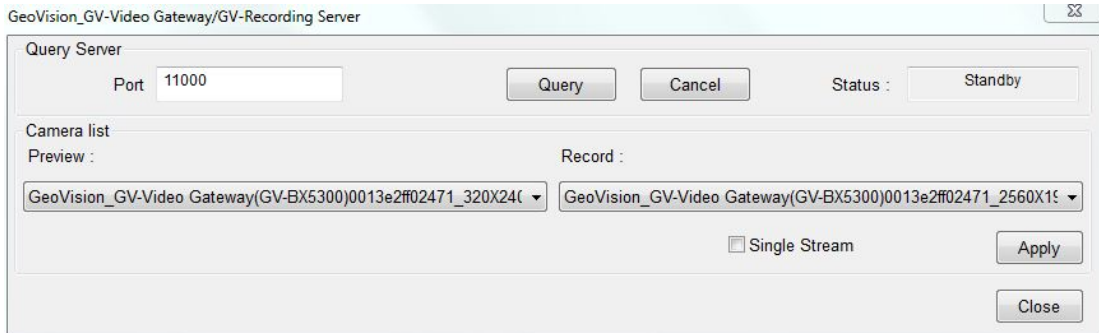

Figure 7-13

4. Keep the default communication port of GV-Recording Server as 11000, or modify the value to match the TCP/IP port on the GV-Recording Server (Figure 5-29). Click the **Query** button to connect. Once connected, the camera options will be displayed in the Preview and Record drop-down lists.
5. Select one camera to be connected. The selections in the Preview and Record drop-down lists will be the same.
6. Click **Apply**. The IP camera is added to the list.
7. To add another IP camera from the GV-Recording Server, click the **Add** button and follow steps 2 to 6. The number of IP cameras you can add depends on your GV-VMS's capacity.
8. Drag and drop the listed cameras to the live view grid for display.

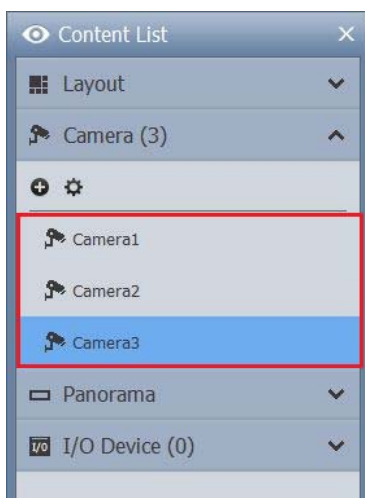



Figure 7-14

- To listen to live audio from the camera, click the **Setup** button  of the connected camera on the IP Device List, select **Audio Settings** and select **Wave Out**.

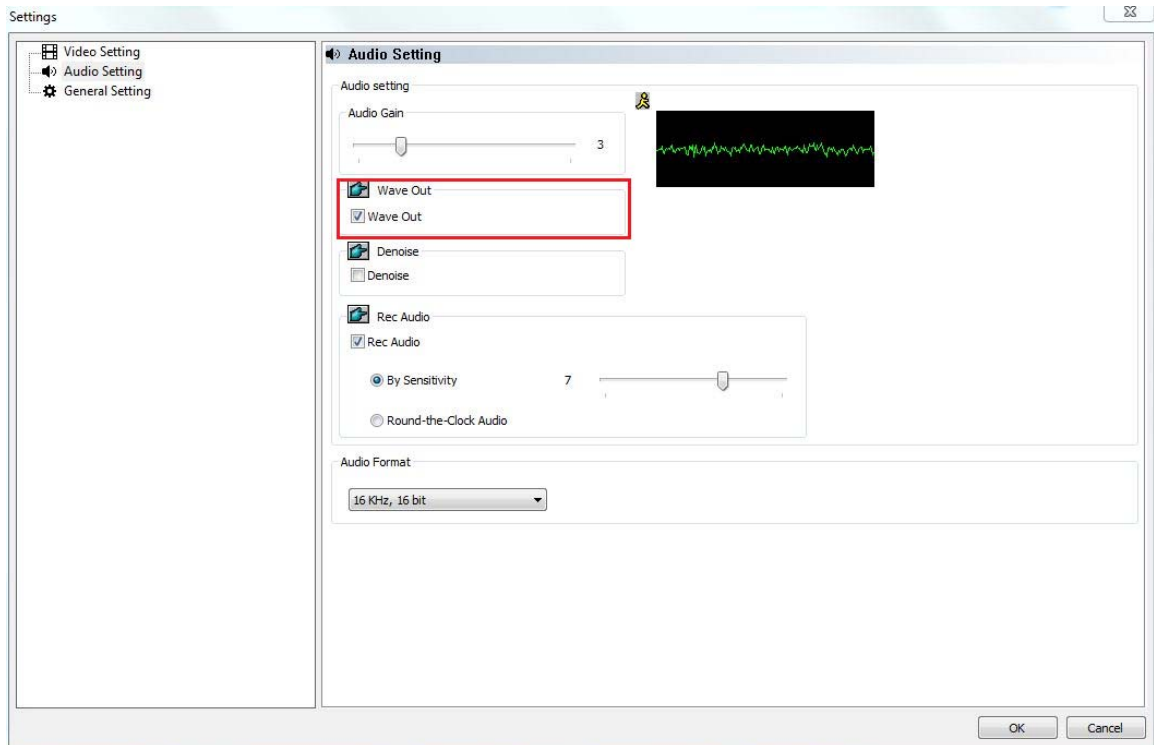

Figure 7-15

- To talk to the surveillance area of the camera, select **Talk Back Toggle**.

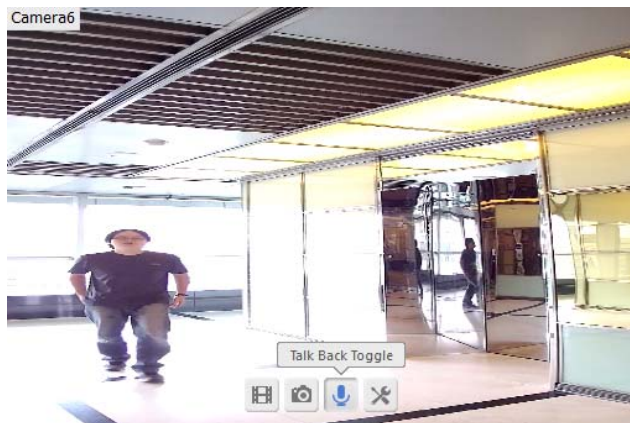

Figure 7-16

For details on GV-VMS, see *GV-VMS User's Manual* from the [GeoVision's website](#).

7.5 Connecting with Remote ViewLog

The recordings of the GV-Recording Server can be played back remotely using the GV-Remote ViewLog V2, which can be downloaded and installed from the [GeoVision's website](#).

1. Once installed, launch GV-Remote ViewLog V2 and create a Remote ViewLog account.

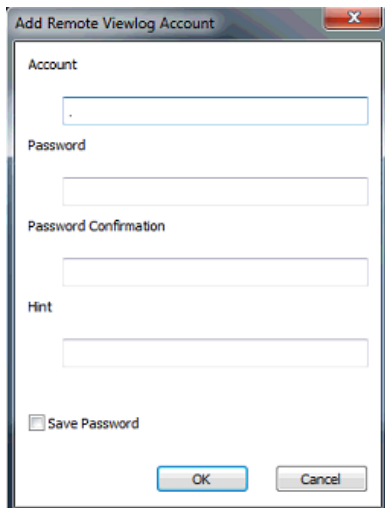

Figure 7-17

2. After creating an account, the Add New Host dialog box will appear.

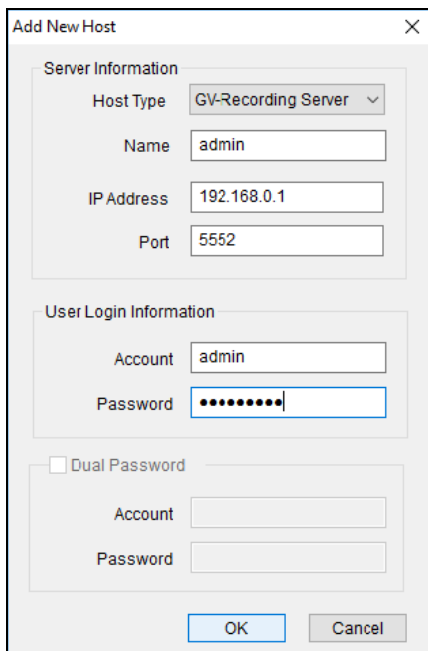

Figure 7-18

3. Select Recording Server under **Host Type**.
4. Type the **Name**, **IP Address**, **Account** and **Password** of the GV-Recording Server, Supervisor or Client. Only modify the default port **5552** if necessary .

5. Click **OK**. The GV-Recording Server is now connected.
6. The ViewLog player appears, with the events listed under the **Event List** tab on the left.

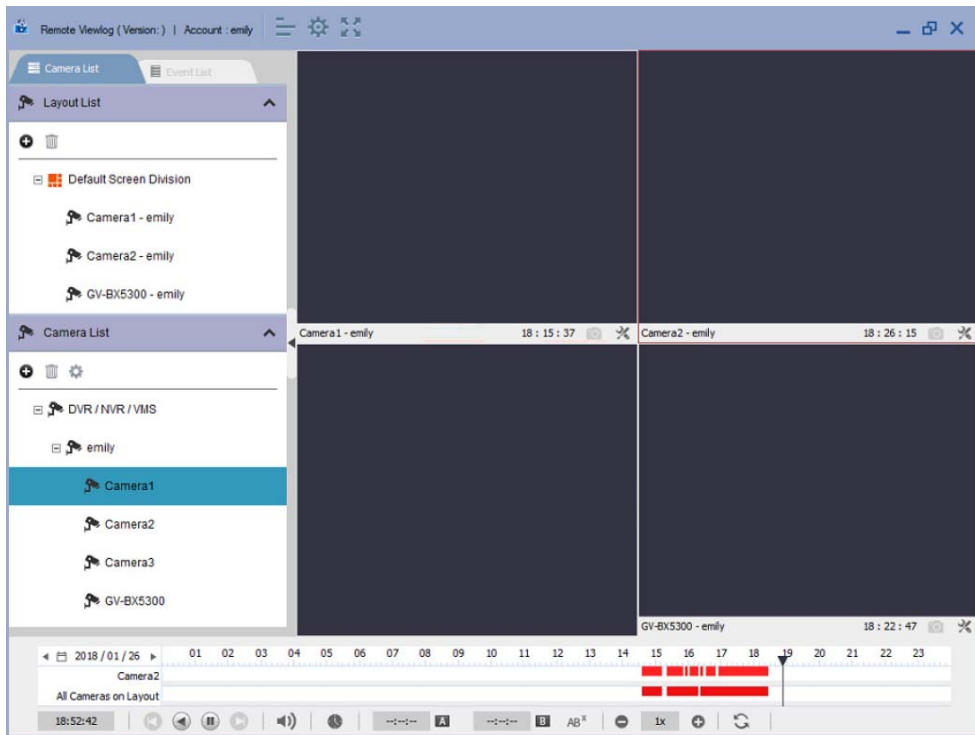

Figure 7-19

For details on GV-Remote ViewLog, see Chapter 4 Video Playback, *GV-VMS User's Manual* from the [GeoVision's website](#).

7.6 Connecting with GV-Control Center

You need to configure the GV-Control Center to access video streaming from the GV-Recording Server. You can download and install GV-Control Center from the [GeoVision's website](#).

Note: The GV-Recording Server is only compatible with the GV-Control Center of version 3.0 or later.

1. On the Host List, right-click **Recording Server List** and select **Add Recording Server**. The Host Settings dialog box appears.

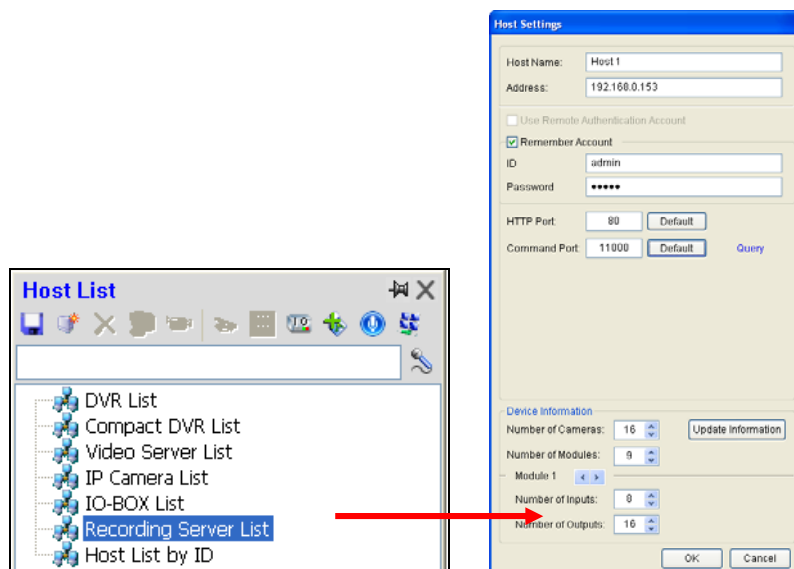

Figure 7-23

2. Name the host of GV-Recording Server.
3. Type the IP address or domain name of the GV-Recording Server.
4. Type the client's username and password created on the GV-Recording Server.
5. Keep the communication ports as default settings; otherwise modify them to match the HTTP (default value: 80) and TCP/IP (default value: 11000) ports on the GV-Recording Server (Figure 5-29).
6. Click the **Update Information** button to request the number of cameras from the GV-Recording Server. When the update is complete, the message "*Update system information successfully*" will appear.
7. Click **OK**. The host is created under the Recording Server List.

For details on GV-Control Center, see *GV-Control Center User's Manual* from the [website](#).

7.7 Connecting with GV-Mobile Server

You need to configure the GV-Mobile Server to access video streaming from the GV-Recording Server. You can download and install GV-Mobile Server from [GeoVision's website](#).

Note: The GV-Recording Server is only compatible with GV-Mobile Server of version 1.3 or later.

1. Select a camera from the left menu and click the **Stream Source** tab. This window appears.

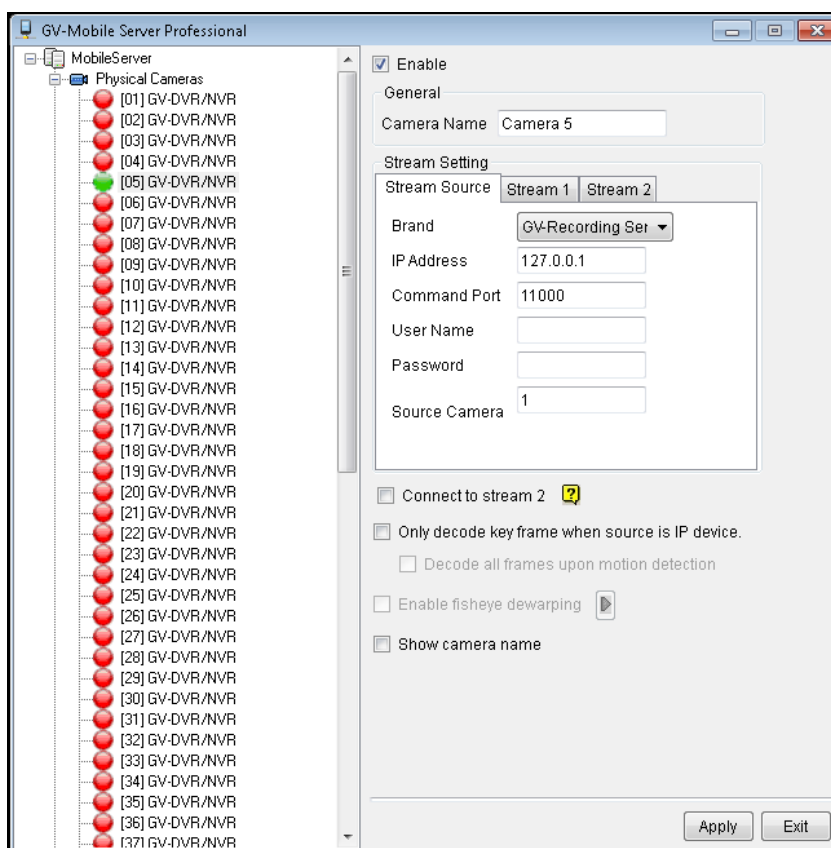



Figure 7-24

2. Type a name to describe the camera in the **Camera Name** field (Max. 31 characters).
3. Configure the connection settings.
 - A. Select **GV-Recording Server** for **Brand**.
 - B. Type the **Command Port**, **IP Address**, **User Name** and **Password** of the GV-Recording Server. The default command port for GV-Recording Server is **11000**.
 - C. Type the camera number for live viewing in **Source Camera**. The default setting is 1.

4. If your GV-IP device supports dual streams, GV-Mobile Server connects to Stream 1 by default. To connect to stream 2, select **Connect to stream 2**.
5. To decode key frames for IP source, select **Only decode key frame when source is IP device**. To decode all frames when a motion is detected and decode key frames when there is no motion, select **Decode all frames upon motion detection**.
6. If the camera is a fisheye camera, select **Enable fisheye dewarping**, and click  to open the FisheyeConfig window. To configure dewarping settings, right-click the image in the window. .
7. To show the camera name specified in Step 2 on the live view, select **Show camera name**.
8. Click **Apply**.

For details on GV-Mobile Server, see *GV-Mobile Server User's Manual* on the [website](#).

7.8 Connecting with GV-Edge Recording Manager

You need to configure the GV-Edge Recording Manager to access video streaming from the GV-Recording Server.

You can download and install GV-Edge Recording Manager from [GeoVision's website](#).

1. From the Host list, click the **Add Host** button  and select a device type. The Host Settings dialog box appears. The settings can vary slightly for different device types. The following is an example of GV-IP Camera.

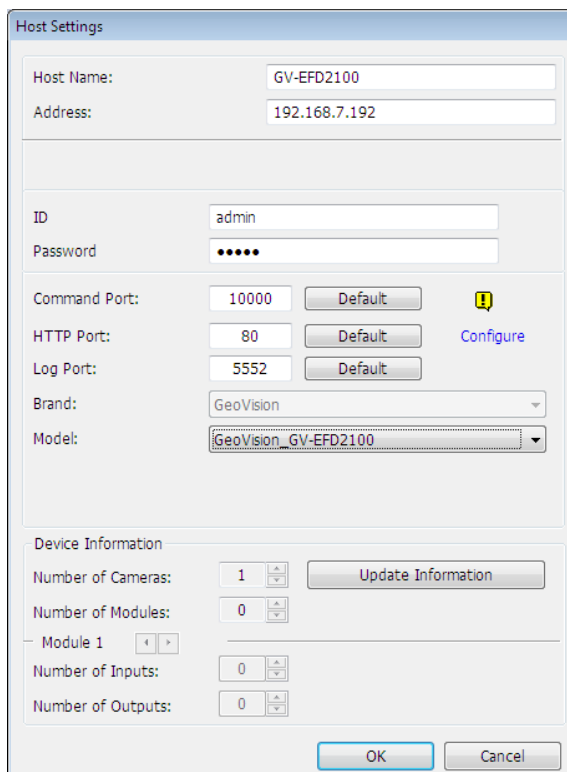

Figure 7-25

2. Type the Host Name, IP address, ID and password of the host. Modify the Communication Port if necessary.
3. Click the **Update Information** button to request the number of cameras and I/O modules installed.
4. Click **OK** to add the host. The host is added to the Host List.
5. Drag and drop the added camera to the Live View Window for live view display.

For details on GV-Edge Recording Manager, see *GV-Edge Recording Manager User's Manual* on the [website](#).

Chapter 8 Useful Utilities

8.1 Windows Lockup

GV-Desktop helps you secure your computer while away from your workstation. You may lock up the Windows desktop while launching a customized GV-Desktop. In the GV-Desktop, users are limited to run the GV-Recording Server and selected programs.

8.1.1 The GV-Desktop Screen

The GV-Desktop is included in the installation of GV-Recording Server. Go to the Recording Server folder located on your computer and double-click **Desktop.exe** .

The GV-Desktop screen appears.

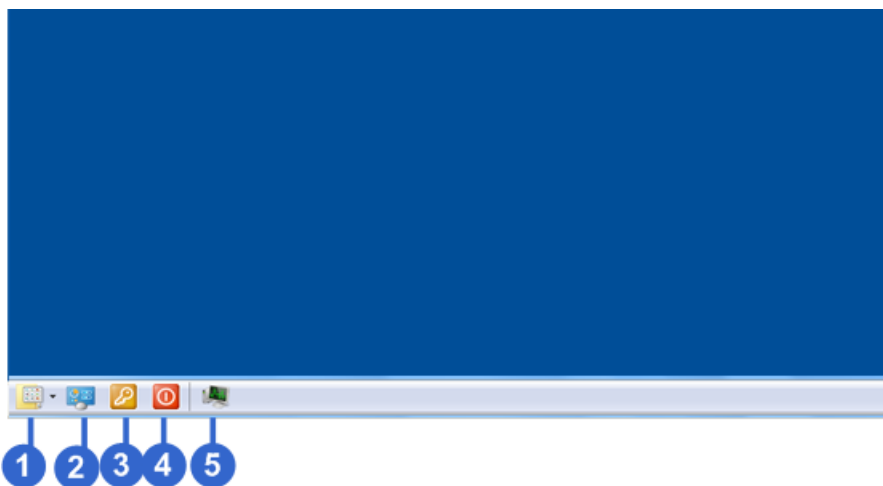

Figure 8-1

The controls in the GV-Desktop screen:

No.	Name	Description
1	Programs	Access programs.
2	Settings	Adds programs to the programs menu.
3	Log Off	Logs off GV-Desktop.
4	Shut Down	Shuts down the computer.
5	Task Manager	Views the tasks currently running on your computer.

8.1.2 The GV-Desktop Screen

The five buttons on GV-Desktop are introduced below.

Programs

Click the **Programs** button (No.1, Figure 8-1) to see the program menu. The default programs are GV-Recording Server and IP Device Utility. To add or remove new programs to the menu, see the *Settings* section later in this chapter. In the example below, Paint is a new program added to the menu.

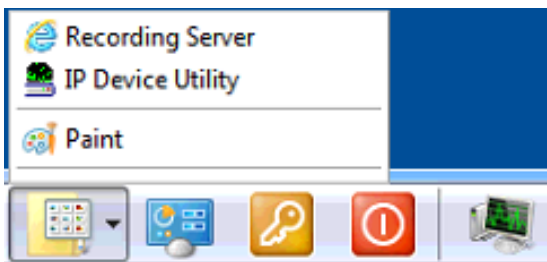

Figure 8-2

Settings

Click the **Settings** button (No.2, Figure 8-1) and type the valid ID and password. This window appears.

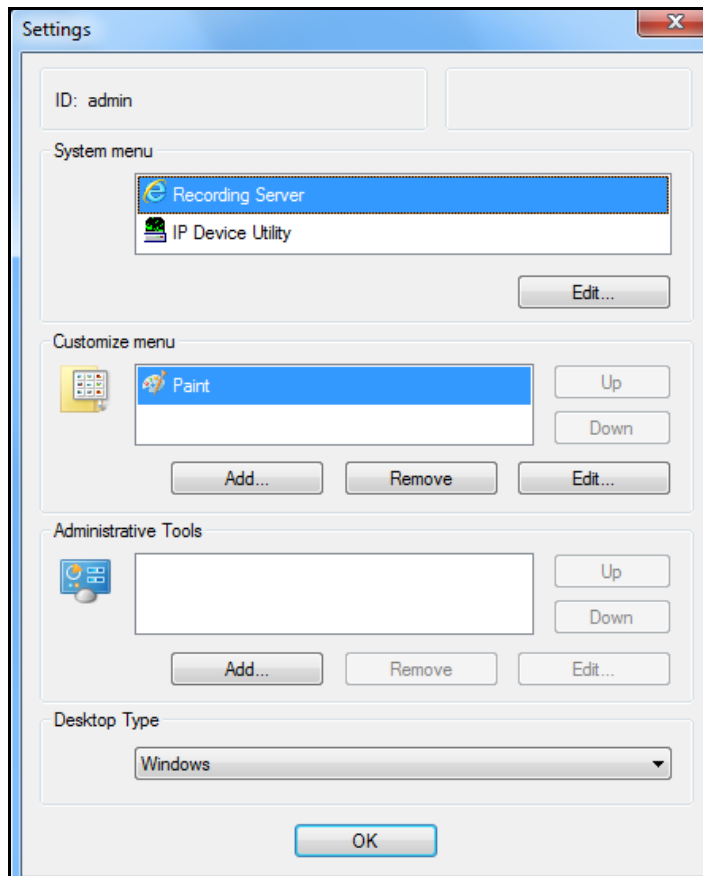

Figure 8-3

[System Menu] Select a desired program and click the **Edit** button to change its name.

[Customize Menu] Set up the Programs menu as desired. To add a program, click the **Add** button. In the Shortcut dialog box, type the program name, click the button next to the field to assign a path and click **OK**.

[Administrative Tools] Set up the Programs menu as instructed In *Customized Menu* option. To run the added programs configured in the Administrative Tools field, the administrative ID and Password are required.

[Desktop Type] Select Windows or GV-Recording Server from the drop-down list. The selected desktop will launch the next time when you log into the computer.

Log Off

Click the **Log off** button (No.3, Figure 8-1) to log off GV-Desktop. A valid ID and password are required.

Shut Down

Click the **Shut Down** button (No. 4, Figure 8-1) to shut down your computer. A valid ID and password are required.

Task Manager

Click the **Task Manager** button (No. 5, Figure 8-1) to view the programs which are currently running on your computer. When you minimize a program, it will be hidden and under operation in the background. To bring the program back to desktop, double-click the program listed in Task Manager.

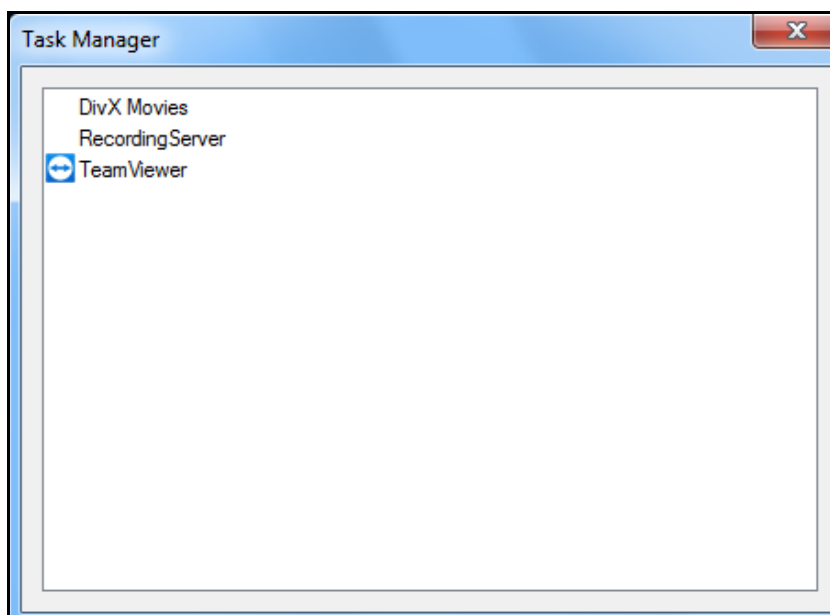

Figure 8-4

8.2 Recording Server Management Tool

GV-Recording Server Management Tool allows users to connect to, monitor and manage multiple GV-Recording Servers at a time.

8.2.1 GV-Recording Server Management Tool Main Screen

GV-Recording Server Management Tool is included in the installation of GV-Recording Server. Go to the Start menu and double-click **GV-Recording Server Management Tool**



The GV-Recording Server Management Tool main screen appears.



Figure 8-5

No.	Name	Description
1	Add New Host	Adds a GV-Recording Server to be managed remotely.
2	Search	Searches and adds all GV-Recording Server within the LAN.
3	About	Views the version information of the software.
4	Server List	Displays all GV-Recording Server added. Users can access the Web interface of any GV-Recording Server added by selecting it from the list.

No.	Name	Description
5	Camera Connection Information	Views the camera connection information of all GV-Recording Server added.
6	Storage Information	Views the storage information of all GV-Recording Server added.
7	Service	Views and enables/disables the Recording Server and/or Video Gateway Services of all GV-Recording Server added.

8.2.2 Adding GV-Recording Server Hosts

Users can add GV-Recording Server hosts to the management tool by one of the two following methods:

- Add manually by clicking **Add New Host** (No. 1, Figure 8-5) and typing the *IP Address*, *Web Port*, *Username* and *Password* of the GV-Recording Server to be added.

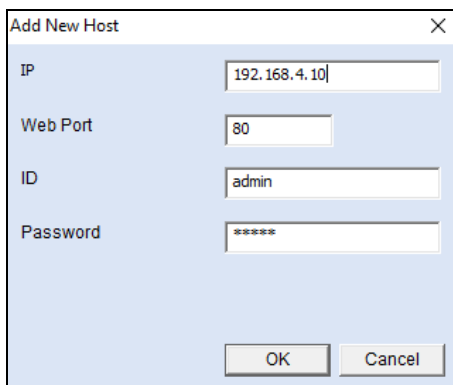

Figure 8-6

- Automatically search and add all GV-Recording within the LAN by clicking **Search** (No. 2, Figure 8-5), selecting the desired *Network Card* and typing a set of *Username* and *Password* for logging into the GV-Recording Servers to be added.

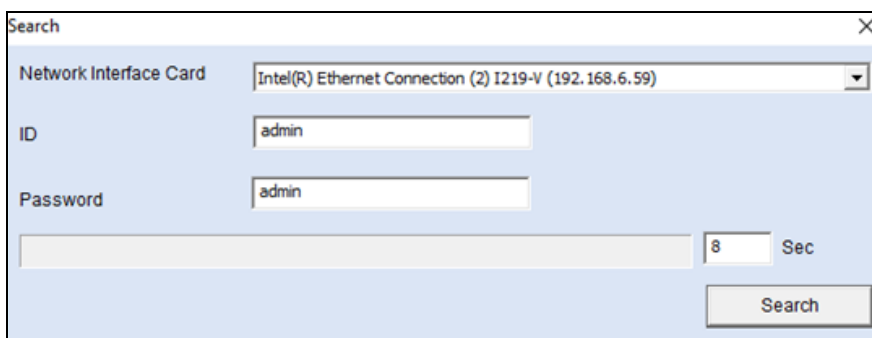

Figure 8-7

Note:

1. GV-Recording Server(s) can only be added to the management tool using the **Administrator** account.
2. To change the Port, Username and/or Password of an added GV-Recording Server, right-click on it from the Server List and click **Login**.

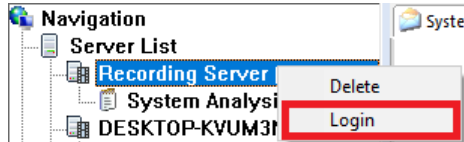

Figure 8-8

8.2.3 System Analysis Report

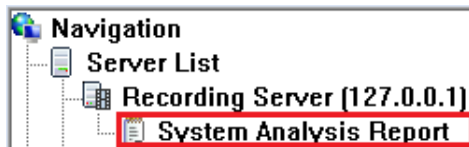

Figure 8-9

Under each of the GV-Recording Server Added, users can view its corresponding **System Analysis Report**, which contains the following analysis information:

- The percentage of storage space used (pie chart).
- The amount of video recordings, in MB, by date (line chart).
- Displays the number of active camera connection lost by host (bar chart).
- The number of abnormal recording events by date (bar chart).

Specifications

For detailed specifications, see [Datasheet](#).

Appendix

A. Settings for Internet Explorer 8 or later

If you use Internet Explorer 8 or later, it is required to complete the following setting.

1. Set the Security to **Medium-high (default)**.
2. Enable **Allow previously unused ActiveX controls to run without prompt**.
3. Disable **Only allow approved domains to use ActiveX without prompt**.

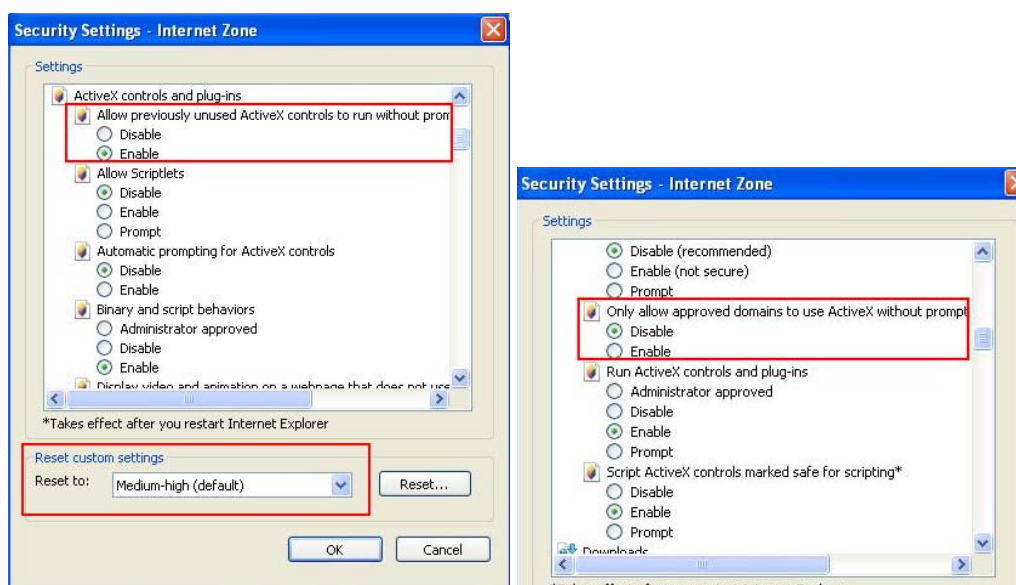

B. RTSP Protocol Support

The GV-Recording Server can support RTSP protocol for video streaming.

To connect using **TCP** port, use the following RTSP command. The default port is 554.

```
rtsp://<Recording Server IP>/<camNo.>_<streamNo.>
```

For example, `rtsp://192.168.3.111/cam1_stream1`

To connect using **UDP** port, use the following RTSP command. The default port range is 17300 to 17380.

```
rtsp://<Recording Server IP>:<port>/<camNo.>_<streamNo.>
```

For example, `rtsp://192.168.3.111:17300/cam1_stream1`

Note:

1. The RTSP server must be enabled on the Web interface. See Figure 5-29.
 2. H.264 is the only codec supported by RTSP streaming.
 3. Only VLC media player and QuickTime Player are supported for streaming H.264 video via RTSP protocol.
-

C. Installing the Internal USB Dongle

Follow the instructions below to install the internal USB dongle for the GV-Recording Server.

1. Turn off the computer, and open the case.
2. Connect the **GV-Internal USB Dongle** to the USB headers on the motherboard.
3. Remove the wire of the computer's reset switch from the motherboard, and connect it to the **GV-Internal USB Dongle**. Use the supplied Jumper Wire to connect the pins on the **GV-Internal USB Dongle** and the reset pins on the motherboard.

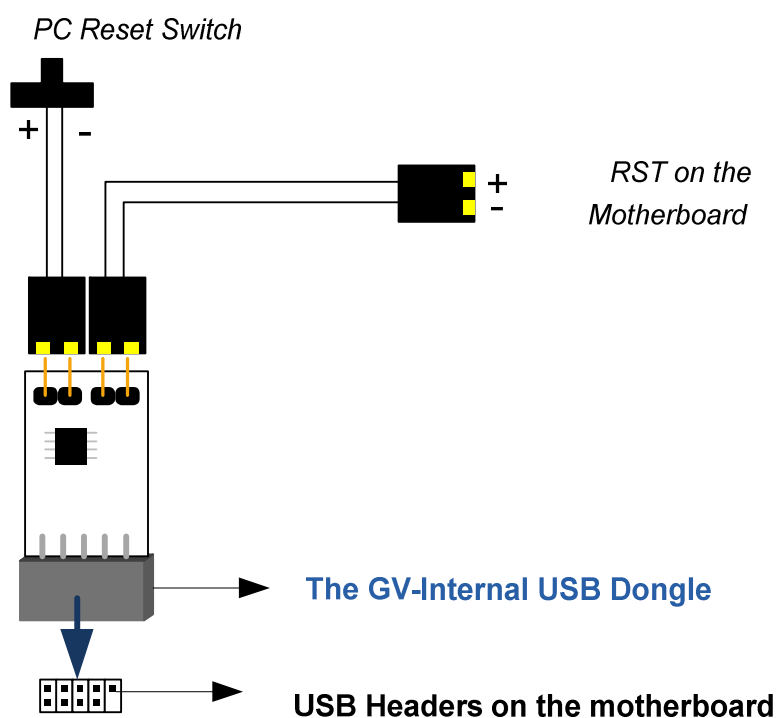

4. For some motherboards, the internal USB headers are integrated with an extra connector, making it unfit for the **GV-Internal USB Dongle** to plug in. In this case, it is required to use a connector supplied with the motherboard to connect the **GV-Internal USB Dongle** to the motherboard.

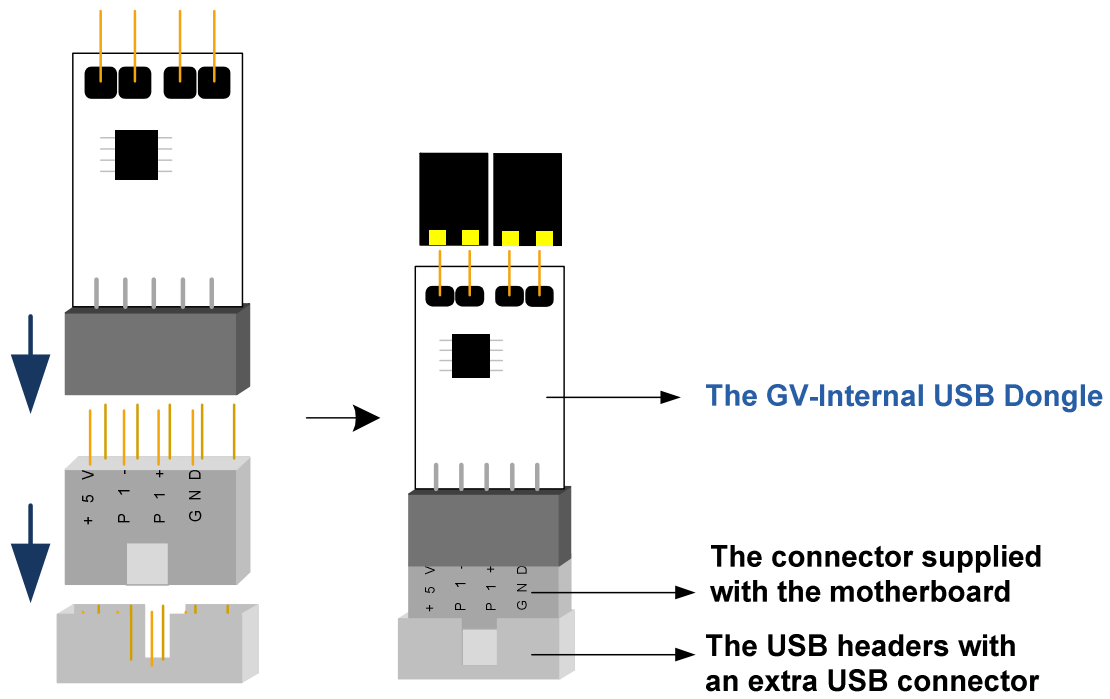

Note: Ensure not to remove the GV-Internal USB Dongle when the computer is powered on; otherwise it would cause the computer to restart or the GV-Internal USB Dongle to be damaged.

D. How to Avoid Network Bottleneck

To increase network bandwidth and avoid network bottleneck, you need to set up multiple networks and divide networks into different multiple subnets or segments. Next, organize IP channels received and clients transmitted into different networks.

1. To set up multiple networks on GV-Recording Server, you need to install multiple network cards. Each network card is assigned a different IP address and subnet mask.

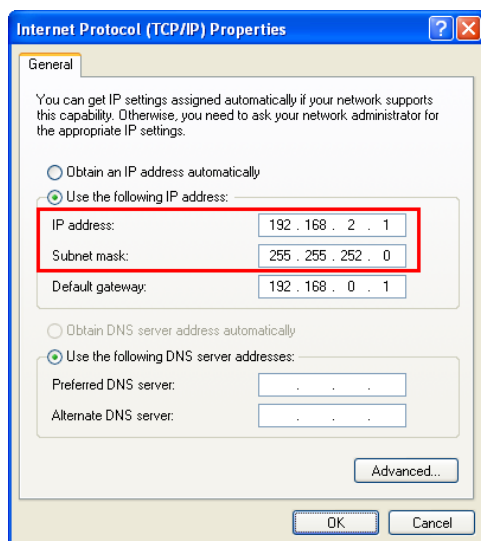

2. Organize IP channels and clients into groups and then assign each group to different network cards using the IP addresses you have set up.

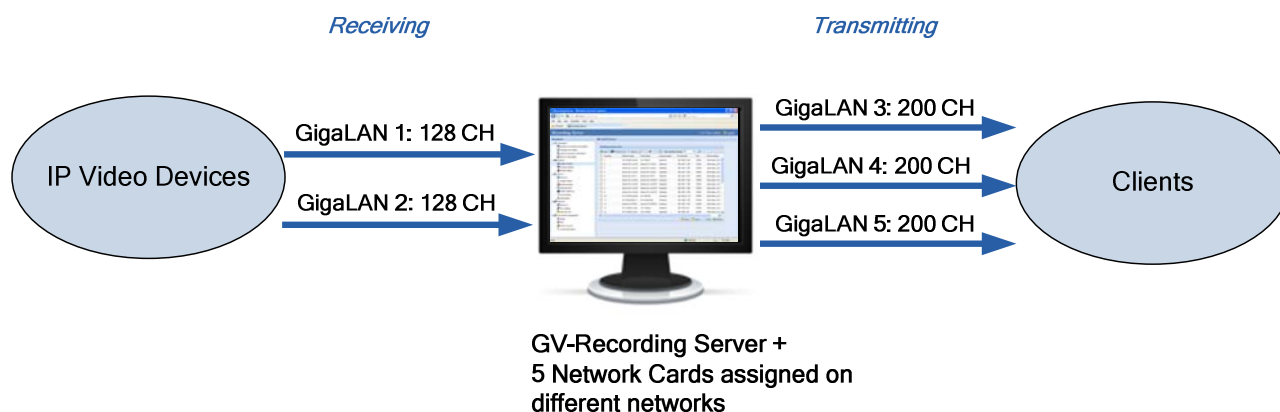

The GV-Recording Server can receive from up to 256 IP channels and transmit up to 600 channels. In the example above, the incoming 256 channels are divided among two network cards and the outgoing 600 channels are divided among three network cards to relieve network congestion.

E. How to Repair the Storage Path

When a storage path or the folder name of a storage path is changed, GV-Recording Server or Remote Viewlog will be unable to locate the altered storage path. You need to use the Repair Tool to repair the storage path. The Repair Tool is a preinstalled program on your computer. Follow the steps below to run the Repair Tool.

1. Close the GV-Recording Server completely.
2. Double-click **RepairTool** from the GV-Recording Server folder. The message of making sure all Recording Server services are disabled appears.

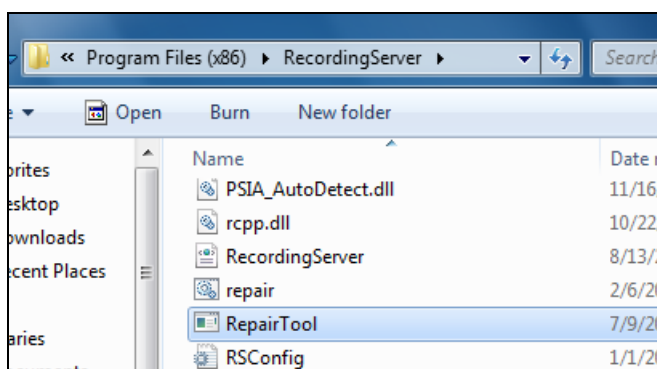

3. Click **OK**. This dialog box appears.

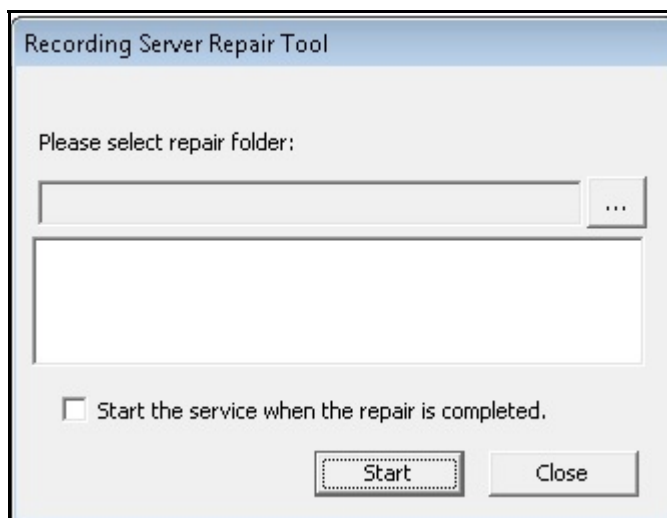

4. Select the new storage path and click **Start**. The repair process usually takes a few minutes to complete.

Note: Select **Start the service when the repair is complete** to start GV-Recording Service automatically once the repair process is finished.

F. Installing .Net Framework 3.5 for Windows Server 2012 and Windows 8

Follow the steps below to manually install **.Net Framework 3.5** for Windows Server 2012 and Windows 8.

Windows Server 2012:

1. Open **Server Manager** from the Start menu.

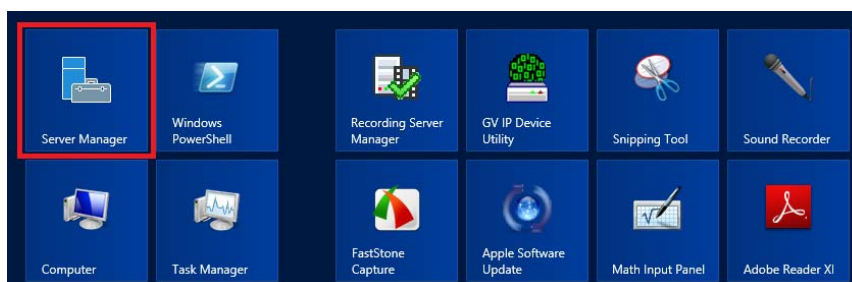

2. Click **Dashboard** from the tree list on the left and click **Add roles and features**.

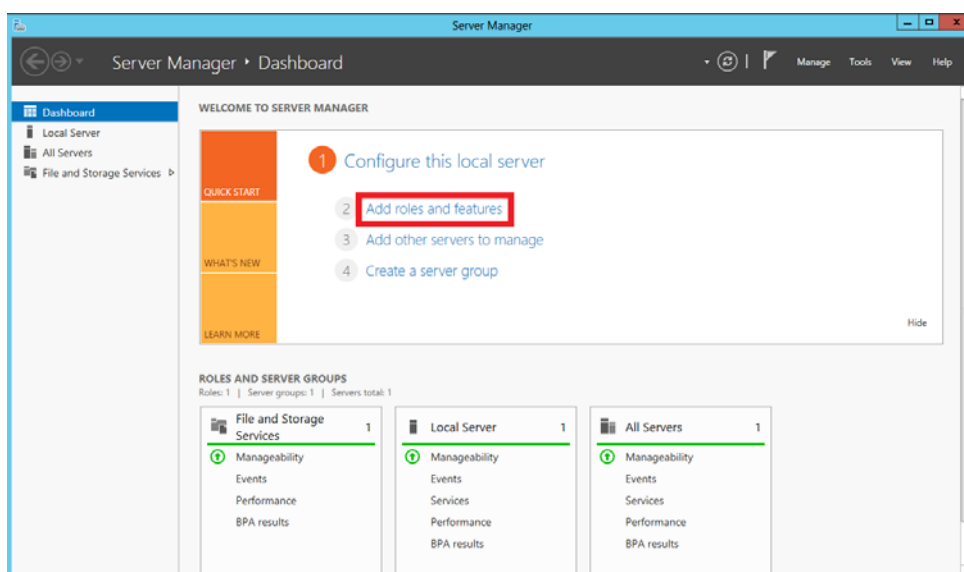

3. Click **Features** from the tree list on the left and select **.Net Framework 3.5 Features**.

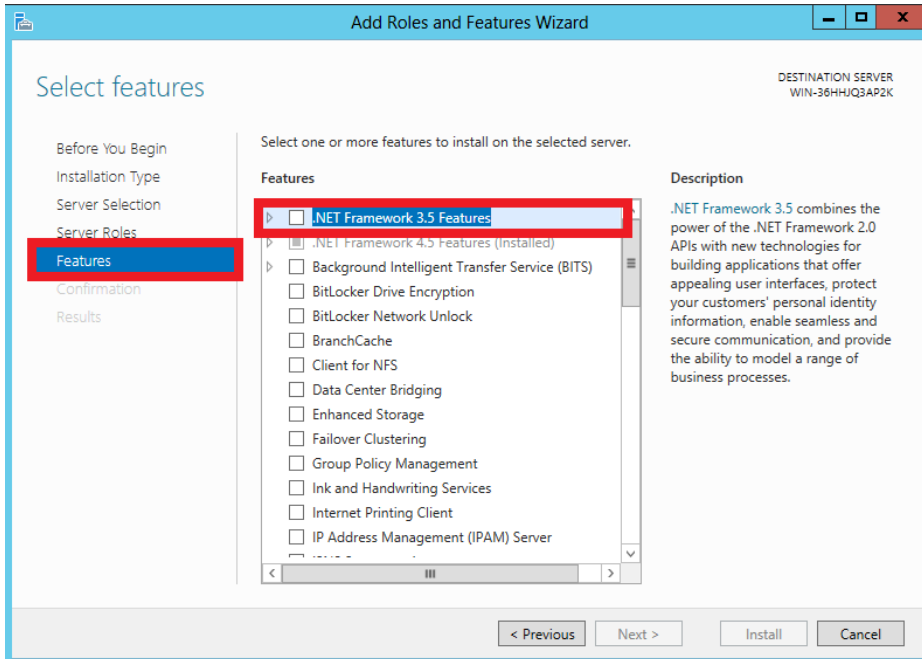

4. Select **.Net Framework 3.5 (include 2.0 and 3.0)** and click the **Install** button.

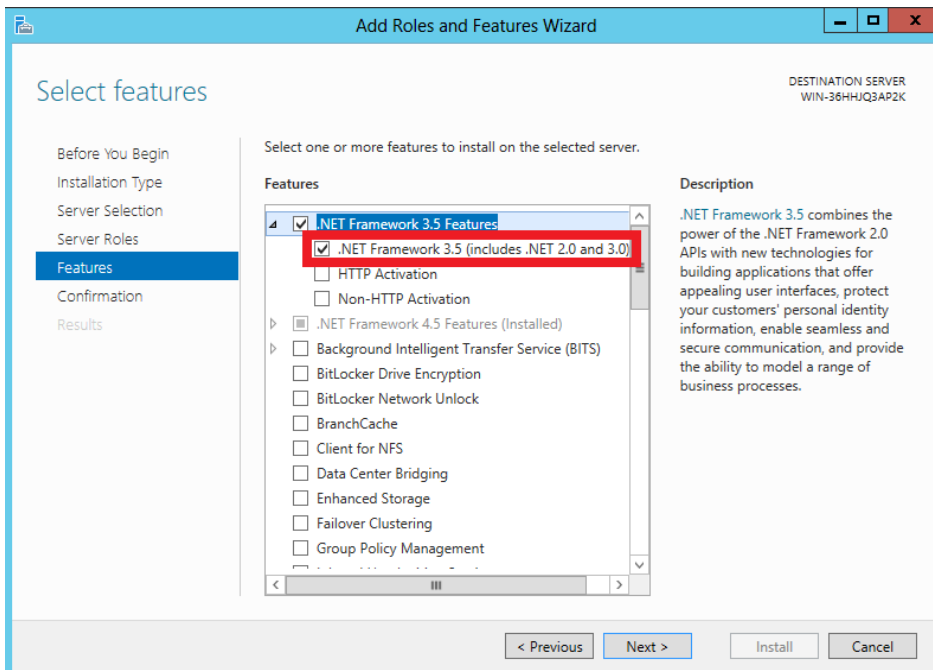

Window 8

1. Click **Control Panel** from the Start menu.
2. Click the **Programs** icon.
3. Select **Turn Windows features on or off** under the Programs and Features title.

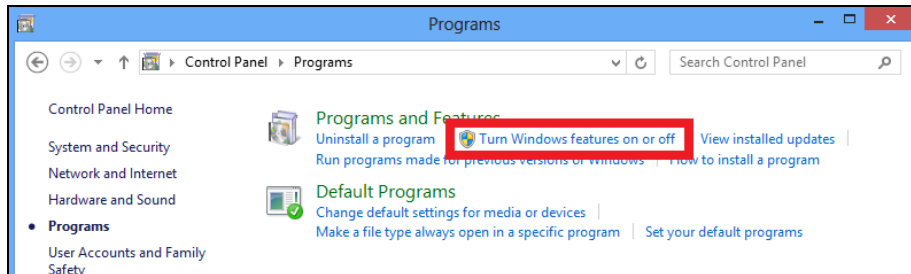

4. Select **.Net Framework 3.5 (includes .Net 2.0 and 3.0)** and click the **OK** button.

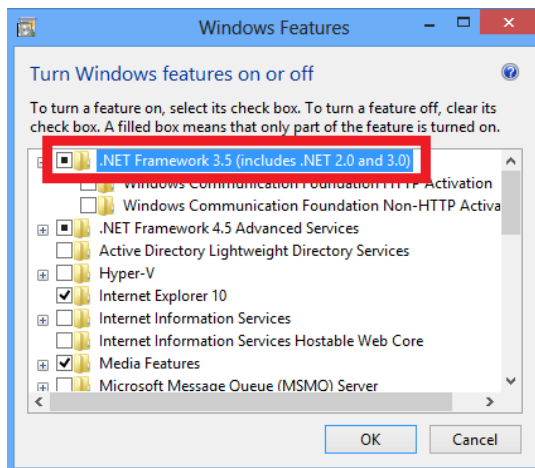

G. Setting Live Streaming on YouTube

To live stream camera live view, you need to have a YouTube account, and complete the required settings to obtain the stream name and RTMP server URL. Click **Live Stream Sharing** under the **Advanced Management** section on the Recording Server, and copy and paste the obtained stream name and RTMP server URL to there. This Appendix will teach you how to schedule a live streaming event.

YouTube:

1. After logging into your YouTube account, click your Account icon and select **Creator Studio**.

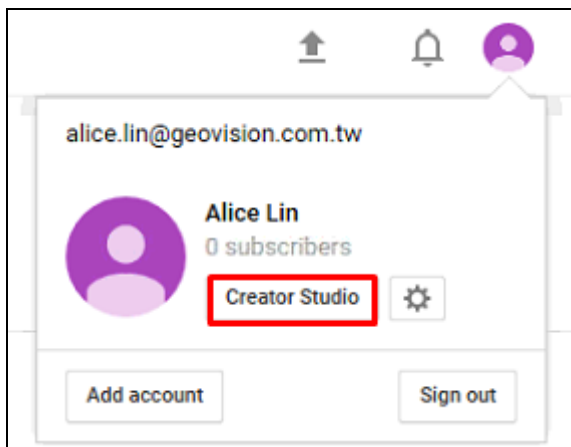

2. Under Creator Studio, click **Live Streaming, Events**, and click the **New live event** button.

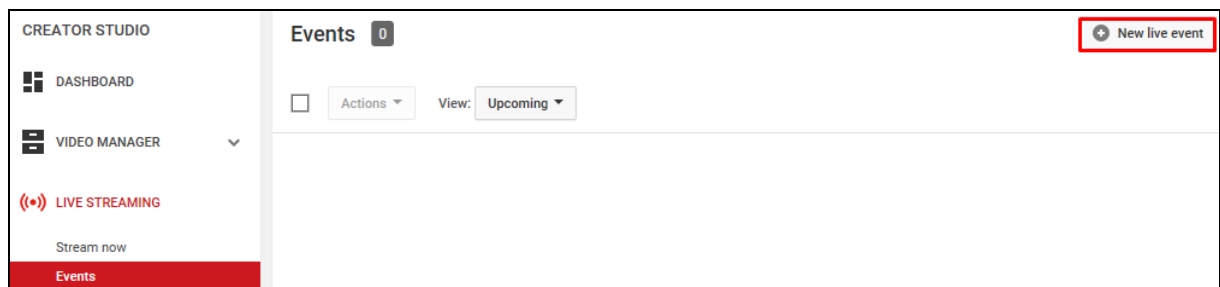

3. Name the live stream, set the Type to **Custom** and click the **Create Event** button. Make sure the video is set to Public or Unlisted.

Recording Server Live Streaming Cancel Create event

Recording Server Live Streaming

Basic info Advanced settings

Recording Server Live Streaming

Public

Today 6:00 PM [Add end time](#)

Taiwan (GMT +08:00) Taipei [Edit](#)

Description

Tags (e.g., albert einstein, flying pig, mashup)

Also share on

Add a message to your video

Type

Quick (using Google Hangouts On Air) ?

Custom (more encoding options) ?

4. Select a **stream key** and set your encoder to **other encoders** to obtain the encoding details.

Select type of stream key

Choose between a single-use or reusable stream key. Reusable keys are named and allow same quality.

NEW You no longer need to specify the resolution and framerate for new stream keys.

Single-use stream key

Reusable stream key ?

Select your encoder

YouTube Live provides support for a variety of encoders. Select one of the encoder optio

Other encoders

1. Configure your encoder
[Recommended bitrates and settings](#)
2. Copy and paste into your encoder
Enter the stream names and URLs in the configuration options of your encoding software.

Stream Name

efbs-4w59-vt16-3003

Primary Server URL

rtmp://a.rtmp.youtube.com/live2

Backup Server URL

5. Copy **Stream name** and **Primary Server URL** to the Recording Server and click **Save changes**.

2. Copy and paste into your encoder
Enter the stream names and URLs in the configuration options of your encoding software.

Stream Name
efbs-4w59-vt16-3003
Primary Server URL
rtmp://a.rtmp.youtube.com/live2
Backup Server URL
rtmp://b.rtmp.youtube.com/live2?backup=1

6. Click **Live Control Room** to preview and start streaming (Creator Studio < Live Streaming < Events).

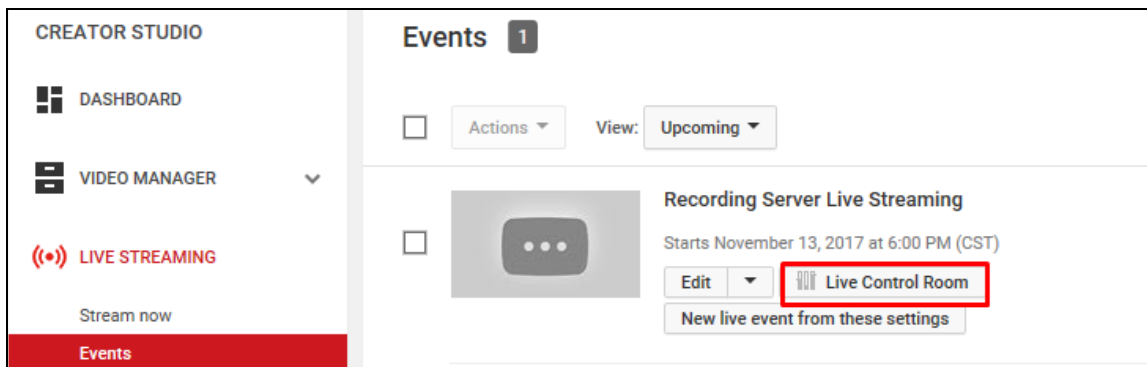

The screenshot shows the YouTube Creator Studio interface. On the left is a navigation menu with 'CREATOR STUDIO' at the top, followed by 'DASHBOARD', 'VIDEO MANAGER', and 'LIVE STREAMING' (highlighted in red). Below 'LIVE STREAMING' are 'Stream now' and 'Events' (highlighted in red). The main content area is titled 'Events 1' and includes an 'Actions' dropdown and a 'View: Upcoming' dropdown. A single event is listed: 'Recording Server Live Streaming', which starts on November 13, 2017, at 6:00 PM (CST). Below the event name are an 'Edit' dropdown and a 'Live Control Room' button, which is highlighted with a red box. A 'New live event from these settings' button is also visible.

You can also watch the demo video below to see how to set up live stream.

https://www.youtube.com/watch?v=gMGNp5735_Y