

IN THE EVENT OF AN EMERGENCY
PUSH EMERGENCY BUTTON
AND AUDIBLE AND VISUAL SIGNAL
WILL ACTIVATE



CX-WEC10 KIT

CX-WEC SERIES

EMERGENCY CALL SYSTEM FOR UNIVERSAL & BARRIER FREE RESTROOMS

FEATURES

- A COMPLETE EQUIPMENT PACKAGE SPECIFICALLY DESIGNED TO MEET THE REQUIREMENTS OF ONTARIO REG. 368/13 AMENDMENT TO 2012 OBC FOR BARRIER FREE & UNIVERSAL RESTROOMS.
- DESIGNED FOR UNIVERSAL RESTROOMS WITH OR WITHOUT LOW ENERGY DOOR OPERATORS.
- FOR USE WITH CAMDEN CX-WC SERIES BARRIER FREE RESTROOM CONTROL KITS.
- AUDIBLE AND VISUAL ANNUNCIATION WITHIN RESTROOM DESIGNED TO CONFIRM A REQUEST FOR ASSISTANCE WITHOUT DISTURBING OCCUPANT. ANNUNCIATION IS ACTIVATED UNTIL MUSHROOM BUTTON IS PULLED 'OFF'.
- AUDIBLE AND VISUAL ANNUNCIATION OUTSIDE RESTROOM OF AN EMERGENCY CONDITION
- 3 YEAR WARRANTY

DESCRIPTION

Camden Door Control CX-WEC Series is an equipment package designed to meet the latest building code requirements for universal restrooms. The kit includes a CM-450R/12 maintained push/pull mushroom button, that activates/ deactivates a call for emergency assistance. Audible and visual annunciation of the request is provided inside the restroom by the CM-AF501SO single gang LED annunciator with sounder, and outside the restroom by the CM-AF140SO single gang dome light with sounder. The equipment package also includes a CM-SE21A 'IN THE EVENT OF AN EMERGENCY' sign, with 1" (25mm) lettering, as required by code.

APPLICATION

Camden Door Controls CX-WEC Series emergency call systems provide a complete equipment package for compliance with building code requirements. They are designed for universal restrooms with or without low energy door operators. The kit includes activation switch, audible and visual annunciation and signage.

ARCHITECTS/ENGINEERS SPECIFICATION

Universal restroom 'EMERGENCY ASSISTANCE' signal activation, annunciation and supporting signage shall be Camden Door Controls model CX-WEC10/CX-WEC11 universal restroom control kit.

The kit shall include:

CM-450R/12 single gang mushroom push button, brushed stainless steel faceplate and red button, maintained push/pull operation with 'PRESS FOR EMERGENCY ASSISTANCE' permanently laser etched on the faceplate.

CM-AF501SO single gang LED annunciator with sounder, rated 85dB at 10cm, weather and vandal resistant construction, brushed stainless steel faceplate, with 'ASSISTANCE REQUESTED' message text, that is not legible unless the annunciator is energized.

CM-AF140SO single gang dome light with piezo sounder, rated 93dB at 1 meter, brushed stainless steel faceplate and 24V incandescent bulb. Text shall be; 'ASSISTANCE REQUIRED'.

CM-SE21A sign, to be located above the activation switch, 1/16" (1.6mm), 6"H x 10 5/8"W, (152mm x 270mm), fire rated expanded PVC white with, 25mm red lettering. Text shall be; 'IN THE EVENT OF AN EMERGENCY PUSH EMERGENCY BUTTON AND AUDIBLE AND VISUAL SIGNAL WILL ACTIVATE'.

CM-450R/12

1 5/8" MUSHROOM PUSH BUTTON, PUSH/PULL, 'PRESS FOR EMERGENCY ASSISTANCE'

- PUSH/PULL MAINTAINED OPERATION
- SINGLE GANG STAINLESS STEEL FACEPLATE
- IMPACT RESISTANT BUTTON AND METAL COLLAR
- TEXT IS PERMANENTLY LASER ETCHED ON FACEPLATE
- HEAVY DUTY 10 AMP CONTACTS, N/O & N/C



CM-450R/12

CM-AF140SO

SINGLE GANG DOME LIGHT, WITH SOUNDER, 'ASSISTANCE REQUIRED'

- 180° VISIBILITY WHEN ILLUMINATED
- LOUD 93 DB PIEZO SOUND ALERT
- NO TOOLS REQUIRED TO CHANGE INCANDESCENT BULB
- SINGLE GANG HEAVY DUTY BRUSHED STAINLESS STEEL FACEPLATE

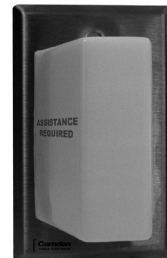

CM-AF140SO

CM-AF501SO

SINGLE GANG ANNUNCIATOR, WITH SOUNDER, 'ASSISTANCE REQUESTED'

- 'ASSISTANCE REQUESTED' MESSAGE ONLY LEGIBLE UPON ACTIVATION
- SUPER BRIGHT LED ILLUMINATION
- SINGLE GANG HEAVY DUTY BRUSHED STAINLESS STEEL FACEPLATE
- 85 DB PIEZO SOUND ALERT IS DESIGNED TO CONFIRM REQUEST WITHOUT DISTURBING OCCUPANT IN SMALL ENCLOSED SPACE



CM-AF501SO

CM-SE21A

SIGNAGE FOR UNIVERSAL RESTROOMS

- COMPLIES WITH ONTARIO BUILDING CODE REQUIREMENTS
- WHITE, 1/16" (1.6mm) THICK PANEL, 6"H X 10 5/8"W, (152mm x 270mm)
- FIRE RATED EXPANDED PVC
- RED 1" (25mm) LETTERING
- EASILY MOUNTED TO WALL (GLUE OR SCREWS)

IN THE EVENT OF AN EMERGENCY
PUSH EMERGENCY BUTTON
AND AUDIBLE AND VISUAL SIGNAL
WILL ACTIVATE

CM-SE21A

EMERGENCY CALL SYSTEM FOR UNIVERSAL & BARRIER FREE RESTROOMS

SPECIFICATION

CM-450R/12

MUSHROOM PUSH BUTTON, PUSH/PULL, 'PRESS FOR EMERGENCY ASSISTANCE'

| | |
|-----------------|---|
| VOLTAGE: | 12/24V AC/DC |
| CONTACT TYPE: | DPST |
| CONTACT RATING: | 10 AMPS |
| TEMP RANGE: | -13°F TO 158°F (-25°C TO 75°C) |
| SWITCH LIFE: | 100,000 CYCLES |
| DIMENSIONS: | 4 1/2" H x 2 3/4" W x 1 3/4" D (114mm x 70mm x 44mm) |
| STD. FINISH: | STAINLESS STEEL |

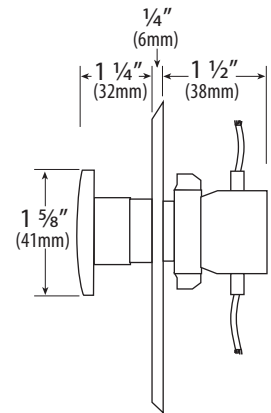
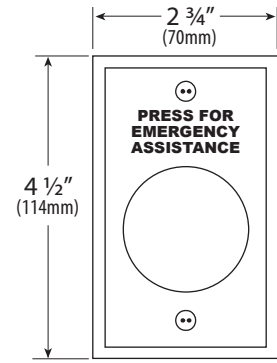

CM-450R/12

CM-AF140SO

SINGLE GANG DOME LIGHT, WITH SOUNDER, 'ASSISTANCE REQUIRED'

| | |
|-----------------|---|
| VOLTAGE: | 24 VDC |
| ILLUMINATION: | INCANDESCENT BULB |
| SOUNDER: | PIEZO, 93 DB MAX. AT 39.4" (1,000mm) |
| CURRENT RATING: | PIEZO, 20mA MAX. |
| TEMP RANG: | 32°F - 176°F (0°C - 80°C) |
| DIMENSIONS: | 4 1/2" H X 2 3/4" W X 1" D (114mm x 70mm x 25mm) |
| STD. FINISH: | STAINLESS STEEL |

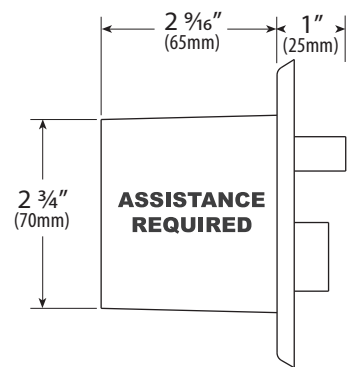
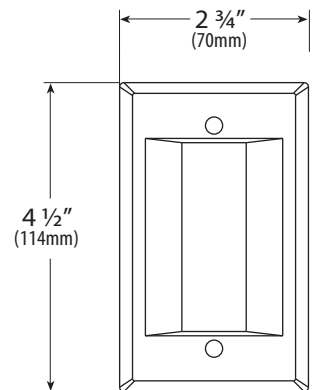

CM-AF140SO

CM-AF501SO

SINGLE GANG ANNUNCIATOR, WITH SOUNDER, 'ASSISTANCE REQUESTED' (MESSAGE ONLY APPEARS UPON ACTIVATION)

| | |
|---------------|--|
| VOLTAGE: | 24 VDC |
| ILLUMINATION: | SUPER BRIGHT LEDs |
| SOUNDER: | PIEZO, 85 DB AT 4" (101mm) |
| CURRENT DRAW: | 75mA, MAX. |
| TEMP RANG: | 32°F - 176°F (0°C - 80°C) |
| DIMENSIONS: | 4 1/2" H X 2 3/4" W X 9/16" D (114mm x 70mm x 15mm) |
| STD. FINISH: | STAINLESS STEEL |

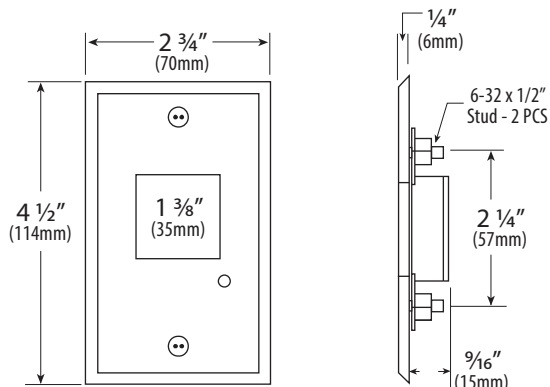

CM-AF501SO

ORDERING INFORMATION

EQUIPMENT PACKAGE

- CX-WEC10** UNIVERSAL RESTROOM KIT FOR USE WITHOUT AUTOMATIC DOOR OPERATOR, OR WITH CX-WC 10, 11, 12, 13 & 14 BARRIER-FREE RESTROOM CONTROL KIT.
INCLUDES: **CM-450R/12** 'PRESS FOR EMERGENCY ASSISTANCE' MUSHROOM PUSH BUTTON, **CM-AF501SO** LED ANNUNCIATOR WITH SOUNDER, **CM-AF140SO** DOME LIGHT WITH SOUNDER AND **CM-SE21A** WHITE PANEL SIGN 6" X 10 5/8" (152MM x 270MM).
ADD SUFFIX 'F' TO MODEL NUMBER FOR FRENCH LANGUAGE.
- CX-WEC11** UNIVERSAL RESTROOM KIT FOR USE WITH CX-WC 15 BARRIER-FREE RESTROOM CONTROL KIT.
AS ABOVE WITHOUT CM-4050R/12 PUSH BUTTON.
ADD SUFFIX 'F' TO MODEL NUMBER FOR FRENCH LANGUAGE.

COMPONENTS

- CM-450R/12:** MUSHROOM PUSH BUTTON, SINGLE GANG, STAINLESS STEEL FACEPLATE, PUSH/PULL, 'PRESS FOR EMERGENCY ASSISTANCE'.
ADD SUFFIX 'F' TO MODEL NUMBER FOR FRENCH LANGUAGE. "
- CM-AF140SO:** SINGLE GANG DOME LIGHT WITH SOUNDER, 'ASSISTANCE REQUIRED'.
ADD SUFFIX 'F' TO MODEL NUMBER FOR FRENCH LANGUAGE.
ADD SUFFIX 'BE' TO MODEL NUMBER FOR ENGLISH & FRENCH BILINGUAL LANGUAGE.
- CM-AF501SO:** SINGLE GANG LED ANNUNCIATOR WITH SOUNDER, 'ASSISTANCE REQUESTED'.
ADD SUFFIX 'F' TO MODEL NUMBER FOR FRENCH LANGUAGE
- CM-SE21A:** ENGLISH, SOLID WHITE SIGN, 6"H X 10 5/8"W (152MM x 270MM).
'IN THE EVENT OF AN EMERGENCY PUSH EMERGENCY BUTTON AND AUDIBLE AND VISUAL SIGNAL WILL ACTIVATE'

OPTIONAL SIGNAGE

- CM-SE21B:** ENGLISH SIGN, WHITE SELF ADHESIVE VINYL, 6"H X 10 5/8"W (152MM x 270MM). ,
'IN THE EVENT OF AN EMERGENCY PUSH EMERGENCY BUTTON AND AUDIBLE AND VISUAL SIGNAL WILL ACTIVATE'
- CM-SF20A:** FRENCH, SOLID WHITE SIGN, 6"H X 10 5/8"W (152mm x 270mm)
'DANS LE CAS D'UNE URGENCE POUSSER LE BOUTON D'URGENCE POUR ACTIVER LE SIGNAL SONORE ET VISUEL'
- CM-SF20B:** FRENCH, WHITE VINYL SELF ADHESIVE SIGN, 6"H X 10 5/8"W (152mm x 270mm)
'DANS LE CAS D'UNE URGENCE POUSSER LE BOUTON D'URGENCE POUR ACTIVER LE SIGNAL SONORE ET VISUEL'

POWER OPTION

- CX-TRK24-50:** 24VAC, 40VA STANDARD MOUNT TRANSFORMER AND AC/DC RECTIFIER