

INSTALLATION INSTRUCTIONS

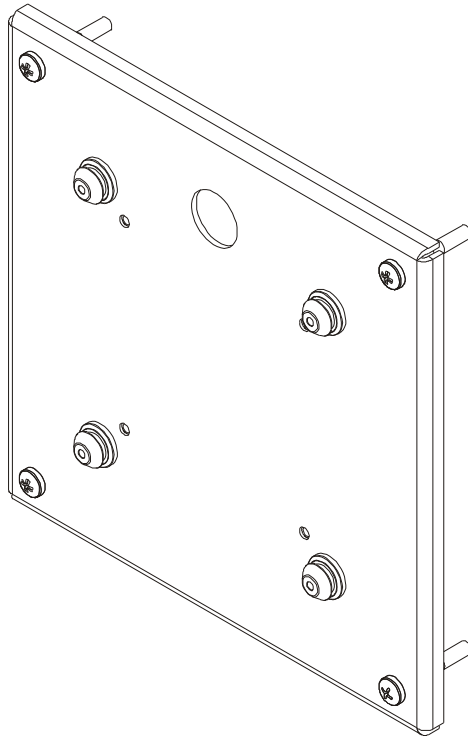

Small Flat Panel Interface Bracket

DISCLAIMER

Milestone AV Technologies and its affiliated corporations and subsidiaries (collectively "Milestone"), intend to make this manual accurate and complete. However, Milestone makes no claim that the information contained herein covers all details, conditions or variations, nor does it provide for every possible contingency in connection with the installation or use of this product. The information contained in this document is subject to change without notice or obligation of any kind. Milestone makes no representation of warranty, expressed or implied, regarding the information contained herein. Milestone assumes no responsibility for accuracy, completeness or sufficiency of the information contained in this document.

Chief® is a registered trademark of Milestone AV Technologies. All rights reserved.

WARNING: A WARNING alerts you to the possibility of serious injury or death if you do not follow the instructions.

CAUTION: A CAUTION alerts you to the possibility of damage or destruction of equipment if you do not follow the corresponding instructions.

MOUNTING SYSTEM: A MOUNTING SYSTEM is the primary product designed by Chief® to mount the projector or display.

ACCESSORY: An ACCESSORY is any product designed by Chief® to complement the primary mounting system either by mounting any supporting components or enhancing the mounting capabilities of the primary mounting system.

COMPONENT: A COMPONENT is any secondary product to be mounted to an accessory, i.e. speakers, CPU's, cameras, tablets, additional displays.

installer's responsibility to make sure all mounting systems/ accessories are properly assembled and installed using the instructions provided.



WARNING: Failure to provide adequate structural strength for this accessory can result in serious personal injury or damage to equipment! It is the installer's responsibility to make sure the structure to which this accessory is attached can support five times the combined weight of all equipment. Reinforce the structure as required before installing the mounting system. The wall to which the mount is being attached may have a maximum drywall thickness of 5/8" (1.6cm). Do not install drywall anchors into the seam between drywall pieces.



WARNING: Exceeding the weight capacity can result in serious personal injury or damage to equipment! It is the installer's responsibility to make sure the combined weight of all components attached to the FSB-4226 bracket including the display does not exceed 45 lbs (20.41 kg).



WARNING: Use this accessory only for its intended use as described in these instructions. Do not use attachments not recommended by the manufacturer.



WARNING: Never operate this accessory if it is damaged. Return the accessory to a service center for examination and repair.



WARNING: Do not use this product outdoors.



IMPORTANT SAFETY INSTRUCTIONS



WARNING: Failure to read, thoroughly understand, and follow all instructions can result in serious personal injury, damage to equipment, or voiding of factory warranty! It is the

--SAVE THESE INSTRUCTIONS--

DIMENSIONS

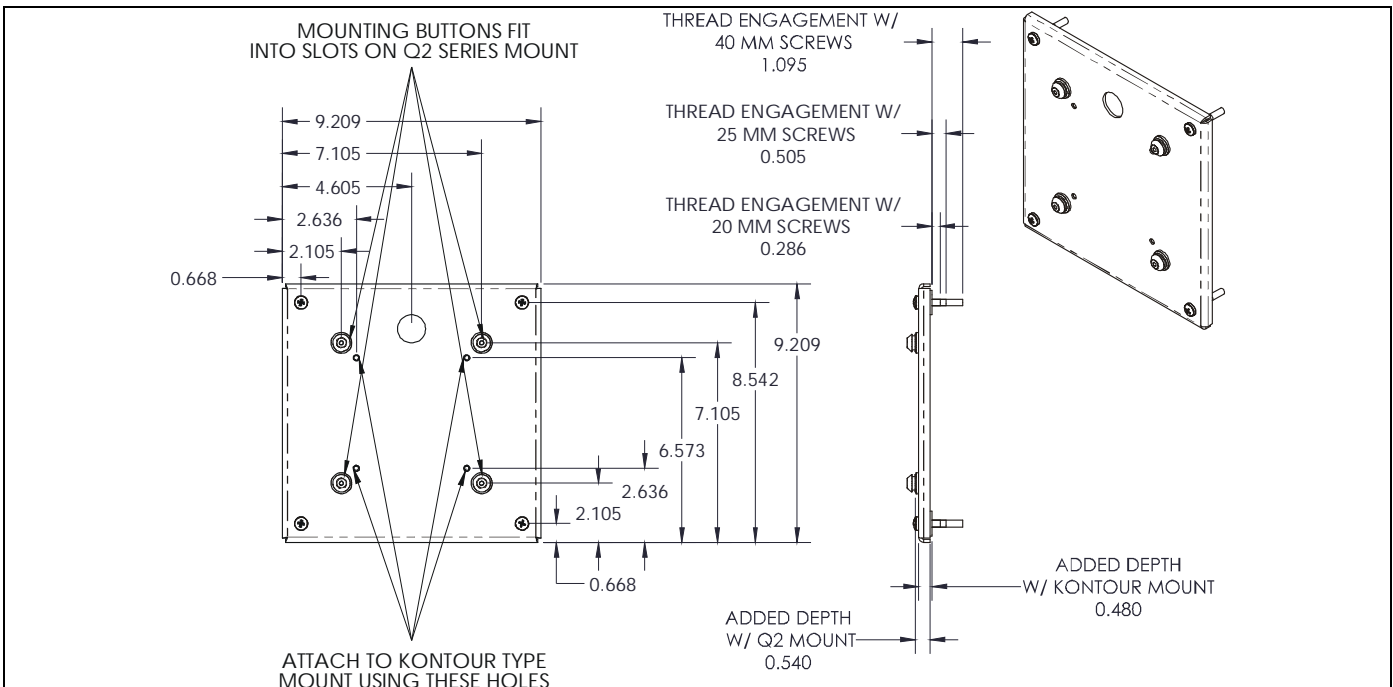

TOOLS / PARTS FOR INSTALLATION

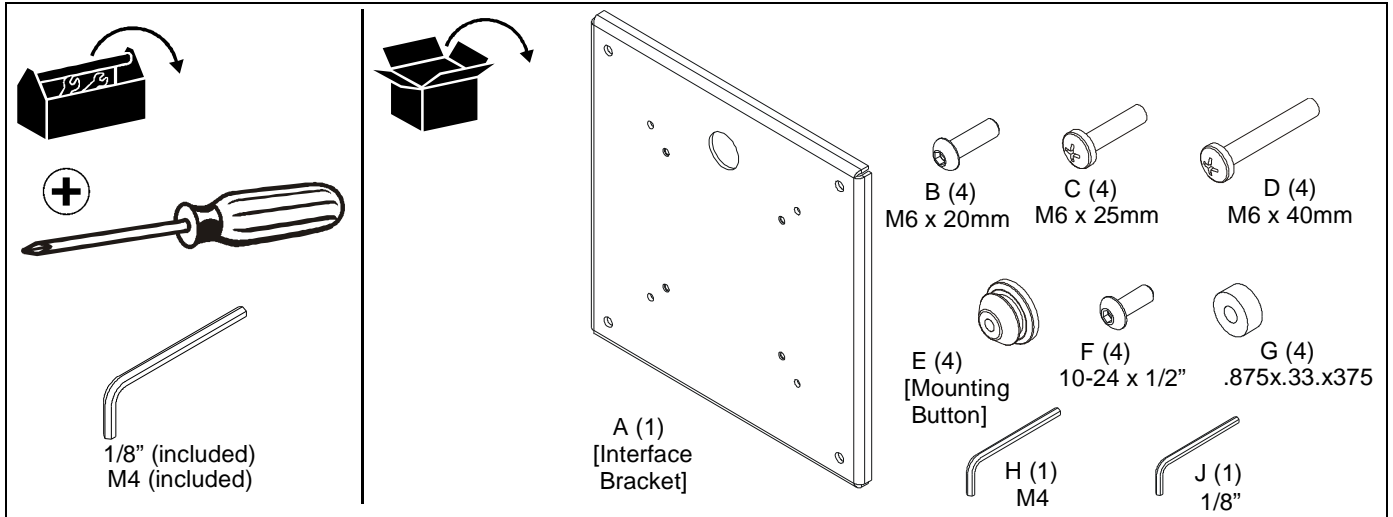

ASSEMBLY AND INSTALLATION

NOTE: For mounts with the Q2™ mounting system (FSM, FPM, FSP, FDP Series products) **proceed to Step 1. Proceed to Step 2 for all other mounts.**

1. Attach mounting buttons (E) to interface bracket (A) using four 10-24 x 1/2" button head cap screws (F) and the 1/8" hex key (J). (See Figure 1)

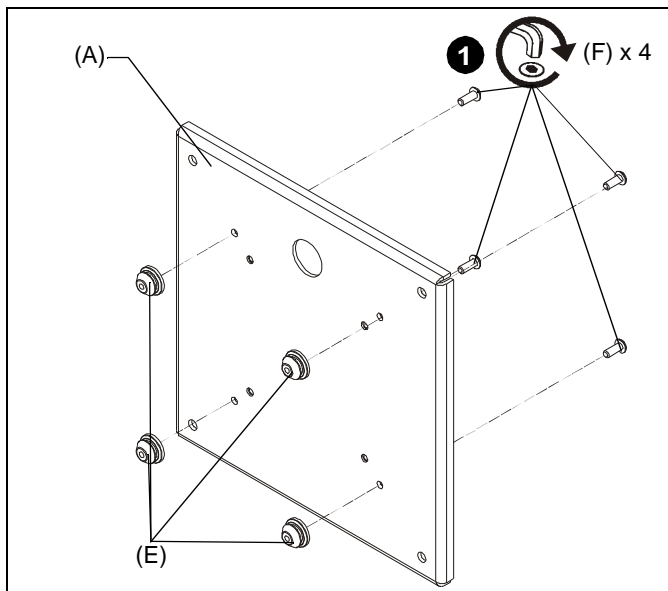

Figure 1



WARNING: IMPROPER INSTALLATION CAN LEAD TO DISPLAY FALLING CAUSING SERIOUS PERSONAL INJURY OR DAMAGE TO EQUIPMENT! Using screws of improper size may damage your display. Properly sized screws will easily and completely thread into display mounting holes. If spacers are required, be sure to use longer screws of the same diameter.

2. Attach interface bracket (A) to back of display using four M6 x 20mm button head cap screws (B) or four M6 x 25mm Phillips head cap screws (C) or four M6 x 40mm and four spacers (G). (See Figure 2)

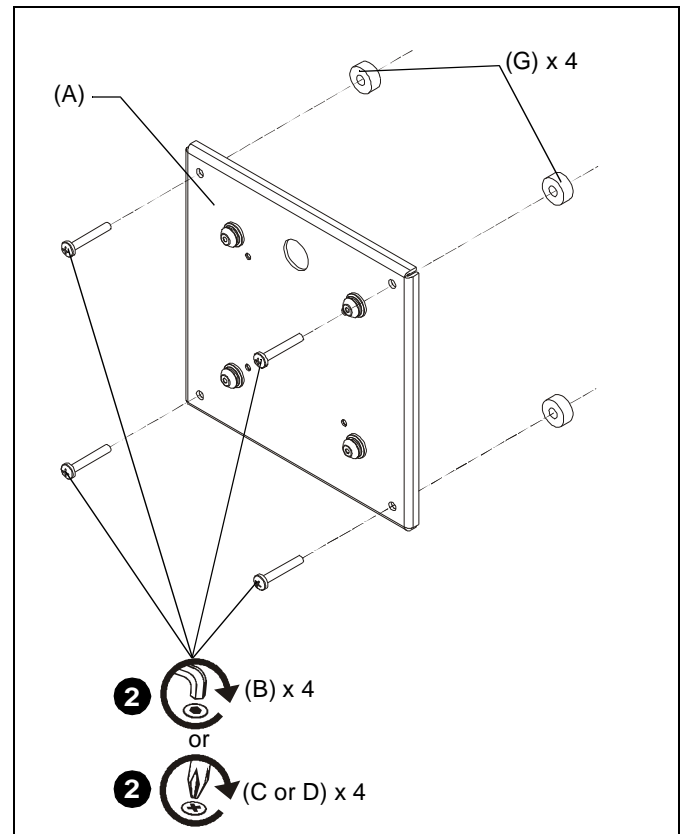

Figure 2

3. Complete the installation following the mount installation instructions.



Our Mounts. **Your Vision.**

Chief, a products division of
Milestone AV Technologies

8800-002807 Rev00
©2016 Milestone AV Technologies
www.chiefmfg.com
01/16

USA/International	A 6436 City West Parkway, Eden Prairie, MN 55344 P 800.582.6480 / 952.225.6000 F 877.894.6918 / 952.894.6918
Europe	A Franklinstraat 14, 6003 DK Weert, Netherlands P +31 (0) 495 580 852 F +31 (0) 495 580 845
Asia Pacific	A Office No. 918 on 9/F, Shatin Galleria 18-24 Shan Mei Street Fotan, Shatin, Hong Kong P 852 2145 4099 F 852 2145 4477

