

DA-500 Drive-Alert Installation Manual



Cover

- 1 Introduction to the **DA-500** and Accessories
- 2-3 **Quick Installation Guide**
- 4 Operation and Adjustment Instructions
- 5-7 Using the DA-500 to control chimes, lights, etc.
- 8 Accessories
- 9 Frequently Asked Questions
- 10 Troubleshooting Guide
- 11 Technical Support and Warranty Information

THE BASICS

- 1 Sensor(s) buried 6-8 inches deep in PVC detect(s) vehicle(s) entering a monitored area
- 2 A control panel receives a signal from the sensor and triggers an alert-whistle inside the control panel

MORE OPTIONS

- 3 Add a remote chime in the front room to alert those on the first floor
- 4 Add another chime in the basement to alert those downstairs
- 5 Add a third chime in an upstairs bedroom to alert those upstairs
- 6 Add a wireless or hard-wired timer controlled light kit to turn on outdoor flood lights, indoor lights and/or lamps to warn strangers or welcome friends
- 7 Attach video surveillance to record activity and display the driveway on a monitor inside
- 8 Add a repeater to send the signal another 1000 feet to trigger alerts in out buildings, or add a DA-660 booster-antenna for buildings up to 8/10-mile away from the control panel
- 9 Activate signs, gates or other equipment

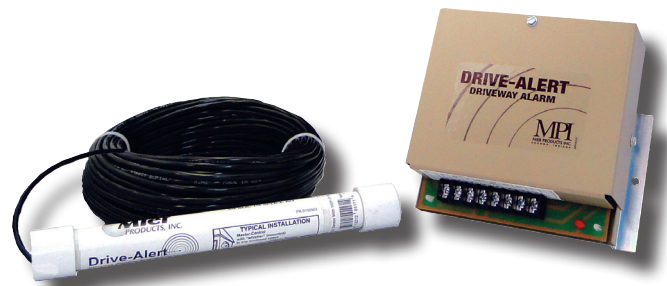

Model DA-500 Information and Most Common Accessories

Drive-Alerts are perfect for use in residential driveways, on farms, at drive-up windows, in remote locations, and to protect valuable assets and equipment such as tractors or construction vehicles. The Drive-Alert will detect a vehicle approaching, or whenever a vehicle or metal equipment is moved.

Drive-Alerts detect metal which contain iron. It will not detect copper or aluminum.

The Drive-Alert's method of operation is to sense the change in the magnetic field. This field is always present, and is disrupted when a metal object moves through it.

The key element in the Drive-Alert installation is to locate the sensor/probe in the area where you wish to detect this change. The usual installation is near the entrance of a driveway, but located far enough away from roads or streets so as not to detect traffic. Moving ferrous (iron) metal trips the sensor. Larger metal objects are detected easier than smaller. Faster moving metal objects are detected easier than slower. Metal moving nearer the probe is detected easier than metal moving farther away. These are the three factors which determine the system's range of detection. Therefore, trucks traveling 65 mph can be detected up to 50 feet; cars moving 5 mph up to 12 feet.

The Control Panel houses the electronics which allows the Drive-Alert to function. It also contains an annunciator, and the terminal strip permits the attachment of the probe as well as accessories or other devices. Adding a DA-500LKA Accessory adds even more extra terminals for additional devices.

Longer lengths of cable are available. Simply order a DA-500CP (control panel only) and a DA-051-___ where you fill in the blanks for the amount of cable needed in 50-foot increments. Ex: DA-051-250 is a sensor with 250 feet.

A Hard-Wired DA-655 Chime with Volume is the most popular accessory for the DA-500, and is HIGHLY recommended for all business, drive-up window, and high-traffic areas where a DA-500 is used. The chime is far more pleasant than the standard whistle inside the DA-500 Control Panel, and the volume control makes it far more versatile.

The DA-505 and DA-505W Hard-Wired Timer Control units are housed in a separate box and attached by wires to the terminal strip on the DA-500 Control Panel. This Timer Control turns on lights for an adjustable period when a vehicle is detected.

The Hard-Wired DA-052V is an additional alert whistle accessory.

Wireless chimes are available with the DA-066MP Chime Transmitter which easily hooks up to the contacts on a DA-500 and triggers DA-078 Wireless Chimes

Wireless light control is available with the DA-606LK with timer control.

DA-500 Kit



Includes a DA-500CP Control Panel, Sensor, 100 feet of cable and UL Listed Power Supply

Accessories



DA-051-___ Probe with cable



DA-500LKA Additional Contacts



DA-655 Chime with Volume



DA-066MP Wireless Chime Transmitter and the DA-078 Wireless Chimes up to 100 feet away



DA-REPEATER to signal DA-100CP Wireless Chimes up to 1000 feet away, or up to 8/10-mile away if using a DA-660 Booster Antenna



DA-505 and DA-505W Timer Control



DA-606LK Wireless Light Kit

DA-500 Kit Contents:

- Solid-state Master Control Panel with Red LED power-on indicator
- Electronic whistle with "on-off" switch
- 100 feet of two-conductor shielded direct burial cable; other lengths available
- Weatherproof sensor
- SPDT relay output available
- UL Listed switching mode power supply, isolated from ground, with input voltage of 100 to 240 50/60HZ, which provides better lightening rejection. Output regulation of 24VDC +/- 0.5A with output short circuit protection with current limit until fault is cleared.

The Control Panel is generally located in a closet, utility room, or garage. 120VAC power outlet must be available. If the only alert used is the one contained within the control panel, the panel must be located where users can easily hear the “whistle.” Accessory chimes are available. The control panel is not suitable for outdoor installation. The ease of routing the three-wire cable from the sensing probe should be considered when deciding the location of the panel. The control panel is usually attached to the wall.

Improper installation is the No. 1 reason for system malfunction. Please use caution when installing the sensing probe to assure a properly operating Drive-Alert.

The probe’s sensor is a coil of wire wrapped around an iron rod. Its DC resistance is 700-1100 ohms. The red and black wires connect to the coil. It is encapsulated in epoxy to protect it from physical damage and moisture.



DO NOT CUT OR NICK THE CABLE JACKET!
If moisture enters, false alarms will be the result!
Mier HIGHLY recommends burying the cable within 1/2-inch PVC pipe for added protection to the cable.



The cable is made with an extra thick outer cover. There is a foil wrapper surrounding the red and black wires. There is a silver (bare) wire in the foil. False alarms will occur if moisture gets into the foil wrapper. Nicks in the outer cover and improper splices allow moisture to enter the cable. As moisture enters the cable, the resistance decreases. Resistance between the red or black wire to the shield wire must be infinite. (Use meter with ability to read resistance above 20 million megaohms).

The ideal installation is without any splices. The use of cable other than that which is designed for the Drive-Alert is undesirable and voids the warranty. Improper splices and unsuitable cable are major causes of false alarms. If splicing is unavoidable, splice the cable using Mier’s DA-054 Splice Kit, or equivalent.

The sensing probe does not know if it is in or out of the ground, but it must remain **absolutely motionless**. Most sensors and the direct burial cable are buried 6 to 8 inches deep and parallel to the driveway. **IT IS HIGHLY RECOMMENDED** the sensor and the cable be buried in PVC pipe to protect them over time from rocks migrating up or down in the ground, or landscaping mishaps.

The probe responds to changes in the magnetic field around it. The signal produced by the coil is a few micro volts for a fraction of a second. The probe and cable must not be within 20 feet of electric wires because they have changing magnetic fields of their own. Never bury the sensor in the same trench with other electrical wires, including telephone wires and wires for lights, bells, etc.

The usual installation of the sensing probe is parallel to an already existing driveway. In this case, the sensor probe and cable can be buried 6 to 8 inches deep below the grass line, recommended in conduit. However, if vehicles are going to travel directly over the probe and cable, they should be buried deeper (see next paragraph).

The burial of the probe is ideal in the center of the area being monitored, but often is not practical. If a new driveway is being put in, the sensing probe could be buried a minimum of 12-24 inches deep. The sensor and cable should also be protected whenever vehicles move over it.

You may wish to place a sensing probe atop the ground in the general area of where you wish to bury it, and connect the cable to the control panel. ****This will allow you to TEST the system in application BEFORE final installation.**** It would be acceptable to leave the sensing probe and cable above the ground for a couple of days, but make certain it is not damaged during this period, and that it is held in place so it will not move. This method should not be used permanently. See OPERATIONS INSTRUCTIONS for adjustments which may be necessary.

The sensing probe may be placed up to 5,000 feet from the Control Panel. Up to 3 sensing probes can be attached to one panel, but each additional probe reduces every probe’s sensitivity and the distance it is able to detect. The Drive-Alert will not know which sensing probe detects a vehicle. If you wish to use “Zoning” with different alerts for different areas, consider a Mier DA-100 or DA-700 Drive-Alert System.

Installation page 2 of 2

Keep the probe, cable, and control panel at least 8 feet away from heavy power lines, power panels, motors, arcing or sparking machinery, and radio transmitters. In some cases, moving the panel and/or cable a few feet can solve interference problems. FIGURE 1 illustrates the contacts on the bottom of the DA-500 Control Panel, with the sensor correctly attached.

When more than 1 probe is used, wire the units in parallel at the terminals on the DA-500 control panel. DO NOT CUT/SPLICE the cables: doing so may allow moisture from entering the cable and causing problems such as false alarms. (See FIGURE 2)



The sensing probe is a 1x12 inches cylinder containing a sealed sensor. Be cautious when handling the sensor and particularly careful to not nick the cable attached to it.

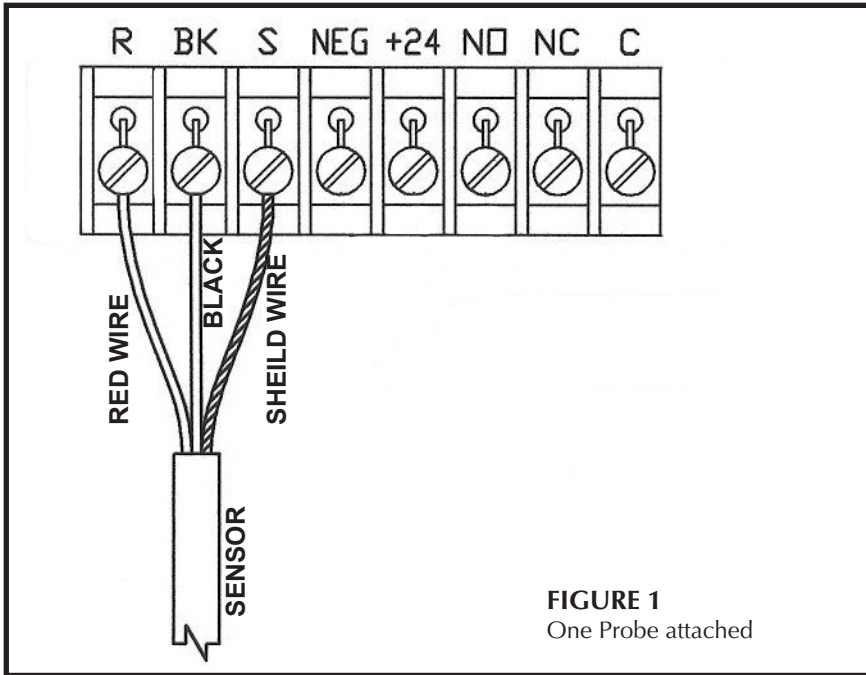

Bury the probe at least 6 inches deep.

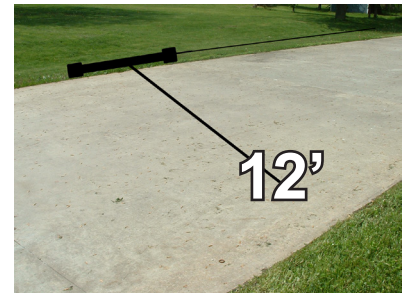

A typical installation is the probe 6 inches deep parallel to drive, which will allow the probe to "sense" 12 feet across the driveway.

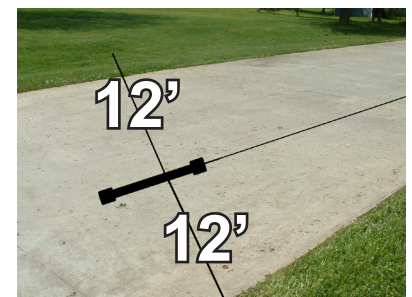
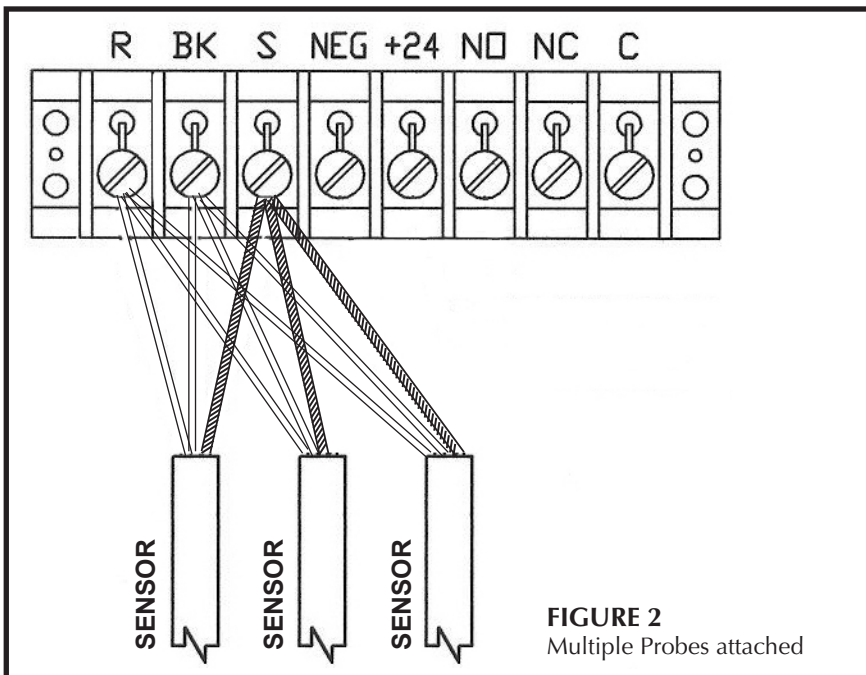

The ideal installation allows you to extend your detection range by installing the sensor under the center of drive.

Operation and Adjustment Instructions

The Drive-Alert is adjusted at the factory for maximum sensitivity for the probe and minimum time for the whistle. To adjust these, open the control panel and adjust the small pots according to the diagram on the inside cover (see FIGURE 2). The whistle "timer adjust" is adjustable from 1-12 seconds and the LED 3 will light.

When first plugged in, the red blanker LED 2 will remain on for only 1 minute, and the Drive-Alert will be muted for approximately 1 minute each time the electrical power is turned on. It provides time for the electronic circuits to initialize.

During normal operation, the noise blanker detects unwanted electrical interference and mutes the Drive-Alert for a few seconds. It has been adjusted at the factory. The blanker light should be off during normal operation.

To test the Control Panel, it is possible to rub your finger simultaneously on the three terminals to which the sensing probe is attached. This should cause the system to go into false alarm. This will occur with or without the sensing probe attached. Be sure the terminal screws are tight while making the test. If the system responds to this test, in almost all instances it indicates a properly functioning control panel.

If false alarms occur, remove the sensing probe wires from the Drive-Alert terminals. Let the power remain turned on to the control panel. If the false alarm stops, then the most likely cause of the problem is moisture in the sensing probe cable. Radio transmitters, cell phones, cordless phones, and wireless modems within 10 feet of the control panel may cause false alarms.

Additional devices can be attached to the Drive-Alert on its terminals at the bottom of the control panel. When the whistle switch is turned off, the Drive-Alert terminals can switch customer provided electrical current up to 5 AMPS. Never attach any device that puts more than 30 volts DC on the Drive-Alert terminals. When the whistle switch is turned on, the Drive-Alert terminals have available 24 VDC at 100 MA. Refer to the diagrams in this manual for hookup instructions.

Mier Products has a hard-wired "timer control" accessory available. The DA-505 Timer Control attaches to the Drive-Alert terminals. This Timer Control is adjustable from 45 seconds to 45 minutes. It switches up to one thousand watts of 115 volt power for outside lights. Mier Products also has a hard-wired chime available. The DA-655 Chime with Volume Control is the most popular accessory for the DA-500, and is highly recommended for drive-up window or business applications. Mier also has a wireless "timer control" kit (DA-606LK) which adjusts from 45 seconds to 45 minutes and includes a DA-071 Light Switch and DA-072 Lamp Module to control lights as an alert in addition to the audible alert. Furthermore, Mier has a chime transmitter (DA-066MP) which triggers wireless DA-078 Wireless Plug-in Chimes.

NOTE: When using multiple accessories, add a DA-500LKA which provides additional relay contacts to a DA-500.

Along with Mier's accessories, the DA-500 can also trigger your other devices such as surveillance, bells, sirens, signs, gates, and much more!

**FIGURE 2
DA-500 CONTROL PANEL ADJUSTMENTS**

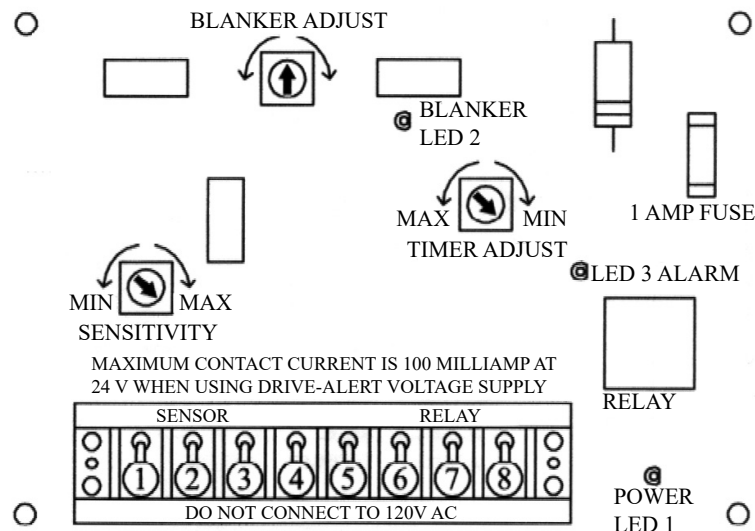

DA-500 Connecting External Hard-Wired DA-655 Chime

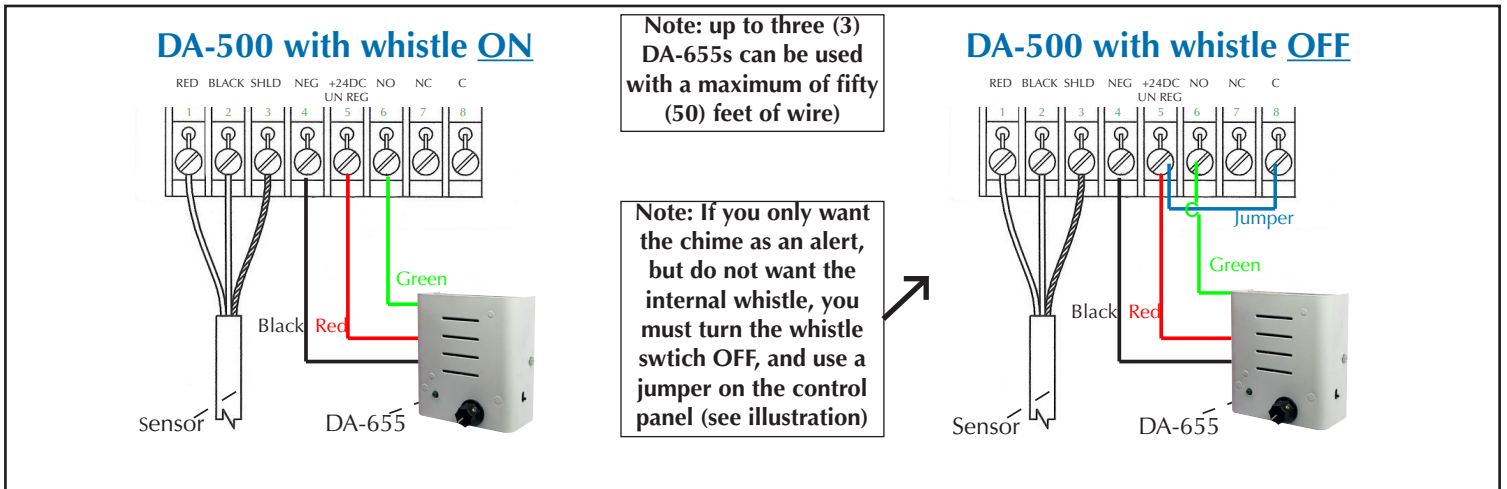

DA-500 Connecting DA-066MP Wireless Chime Transmitter for DA-078s

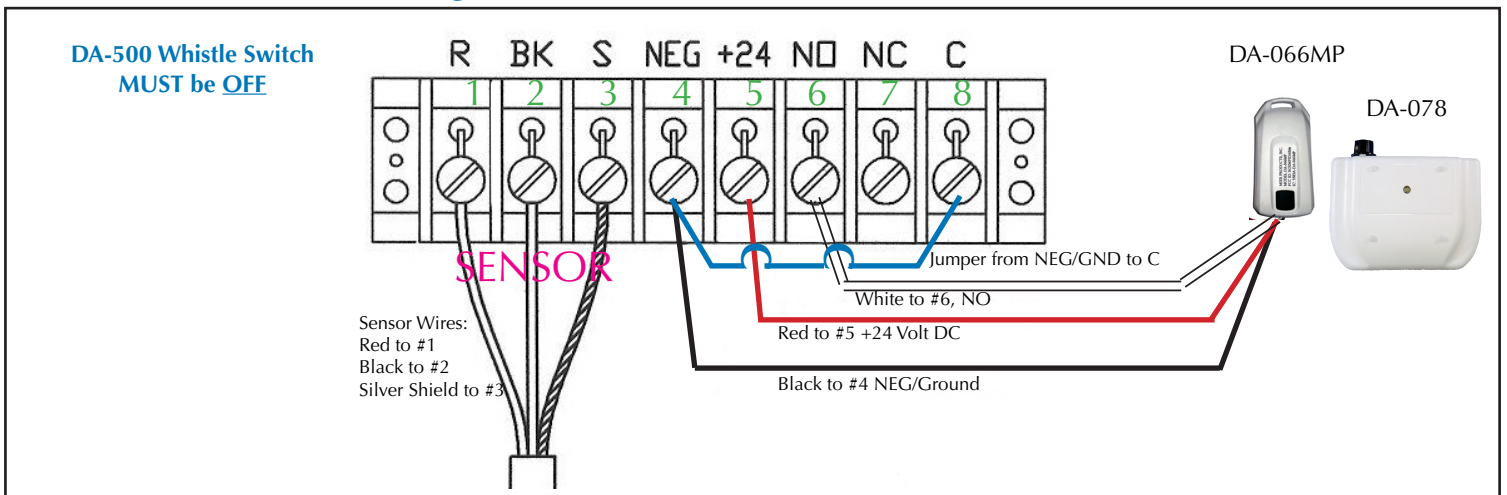

DA-500 Connecting a DA-REPEATER Long-Range Chime Transmitter for DA-100CPs

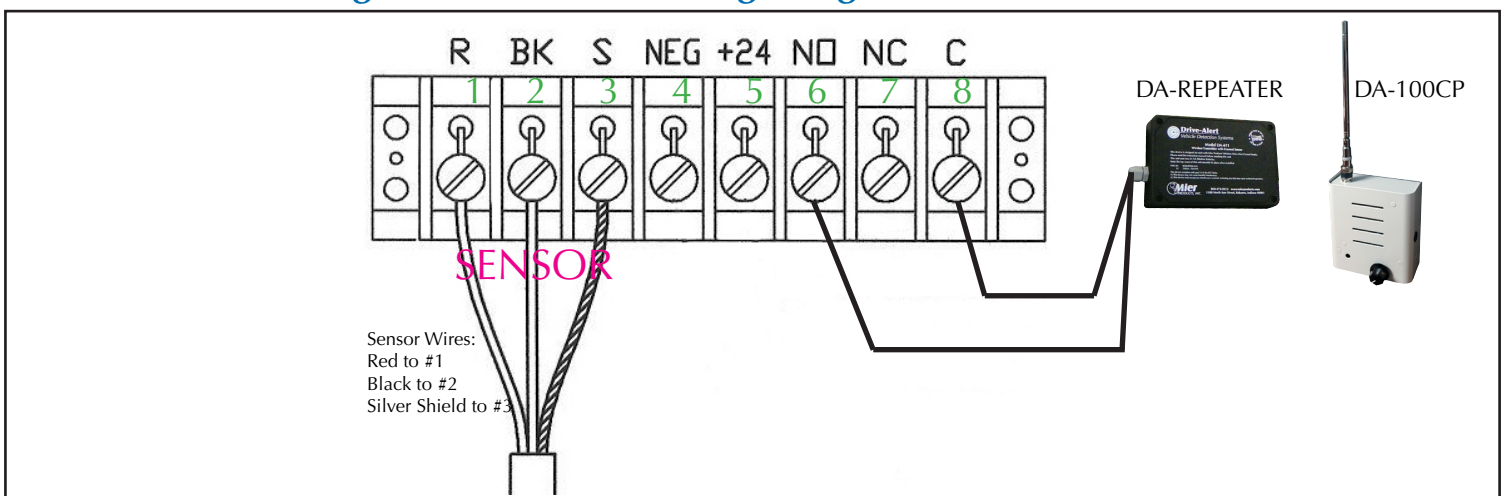

DA-500 and Remote Hard-Wired DA-505 Timer Control Connection for Hard-Wired Lights

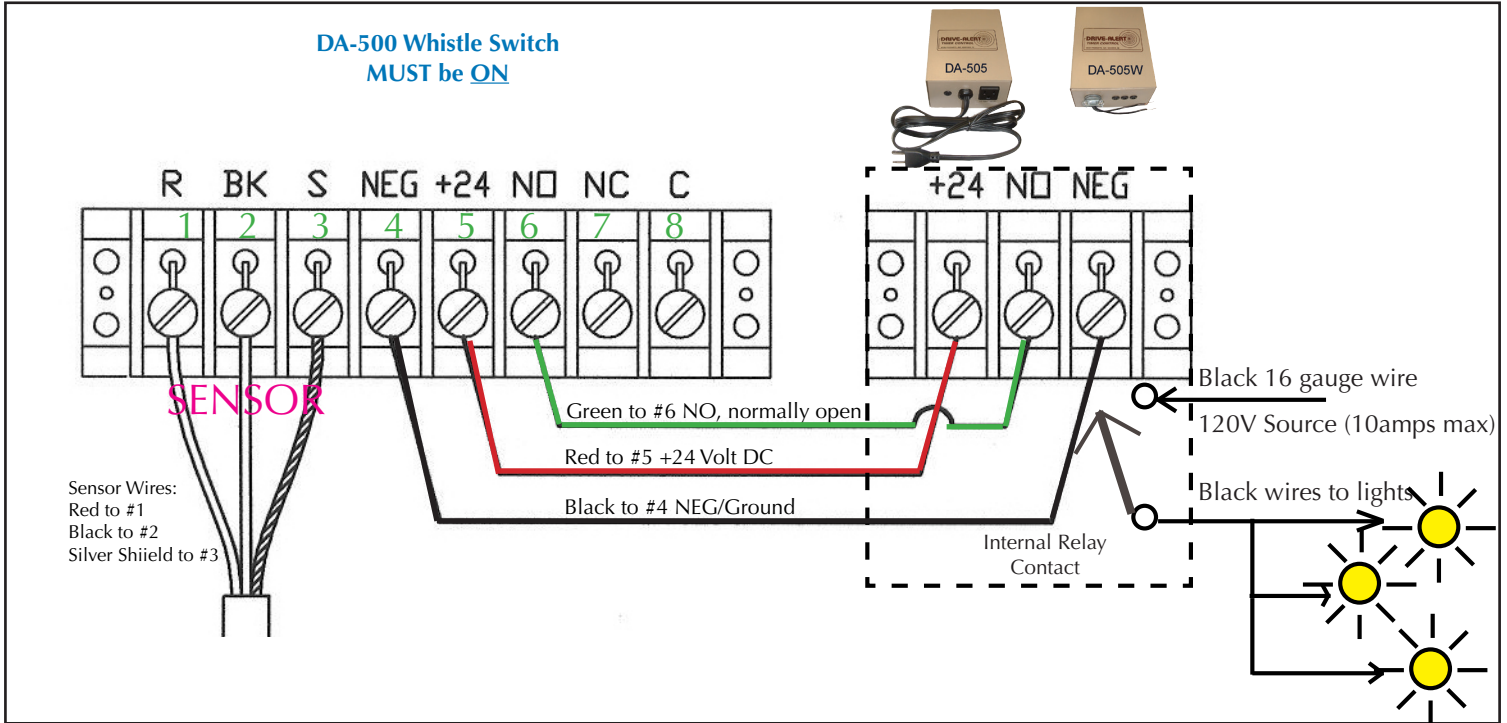

DA-500 and Remote Wireless DA-606 Timer Control Connection for Wireless Lights

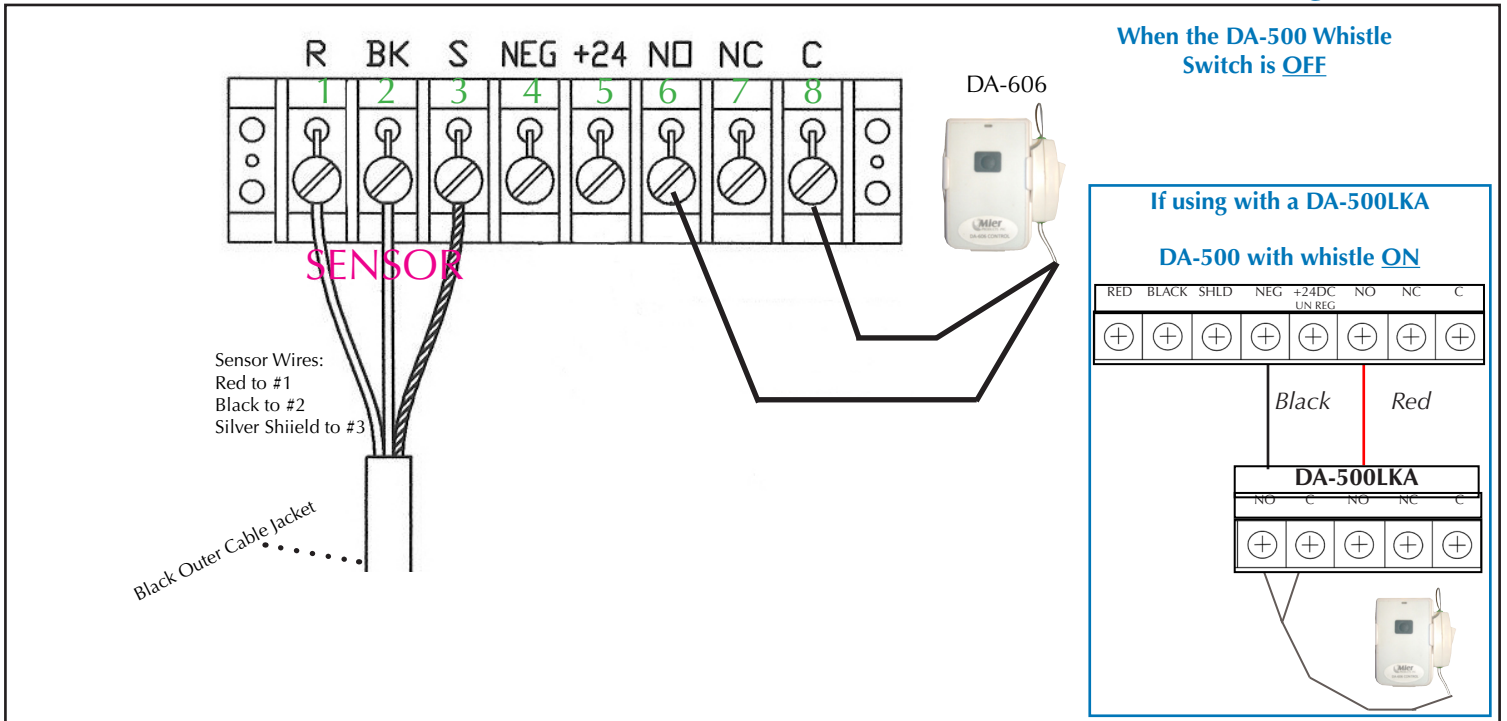

DA-500 and Connecting a DA-500LKA for Additional Contacts

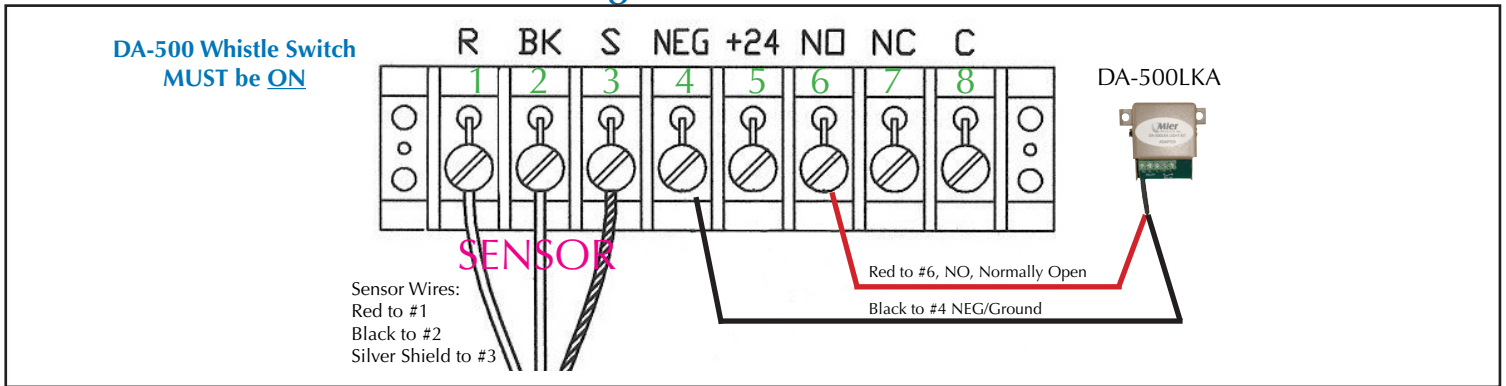

DA-500 and Connecting the DA-052 Whistle, Bells or DA-091 Power Horns

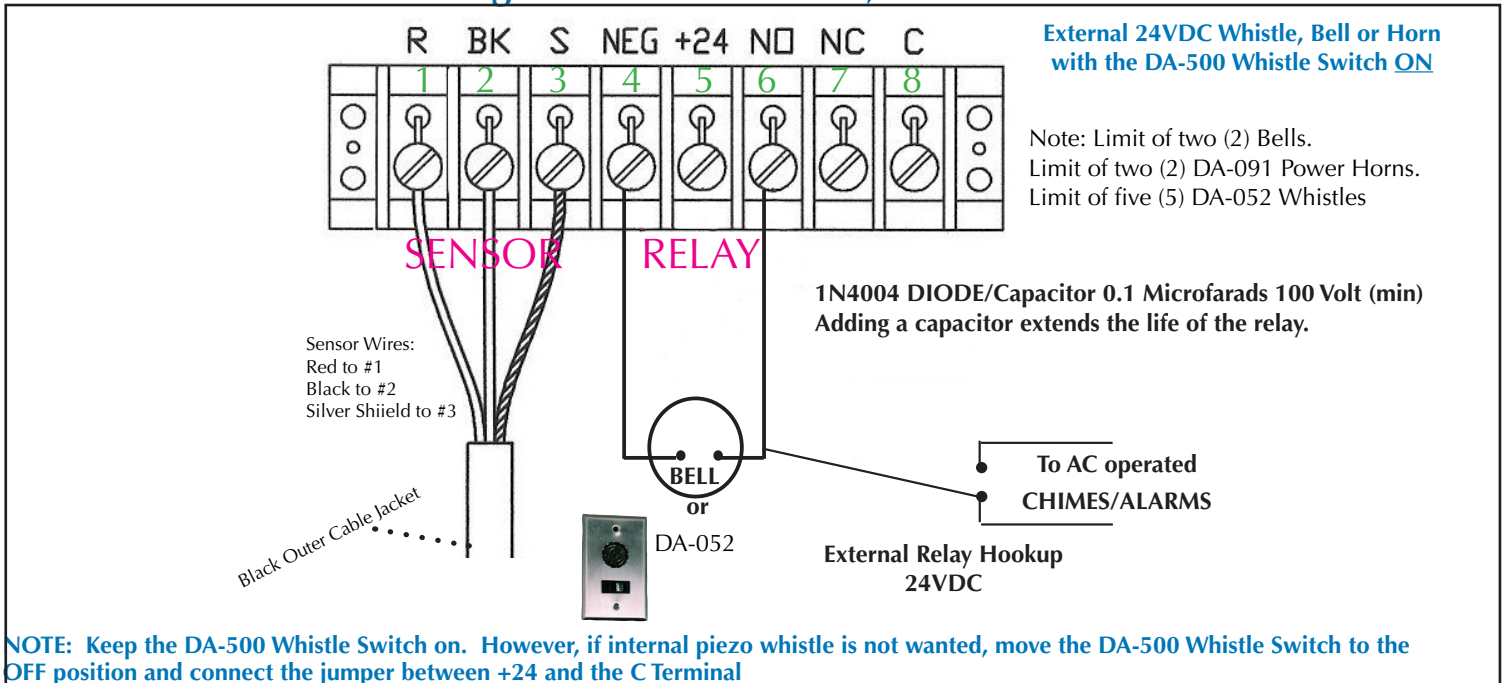

DA-500 and Connection Using Dry Contacts and External Power

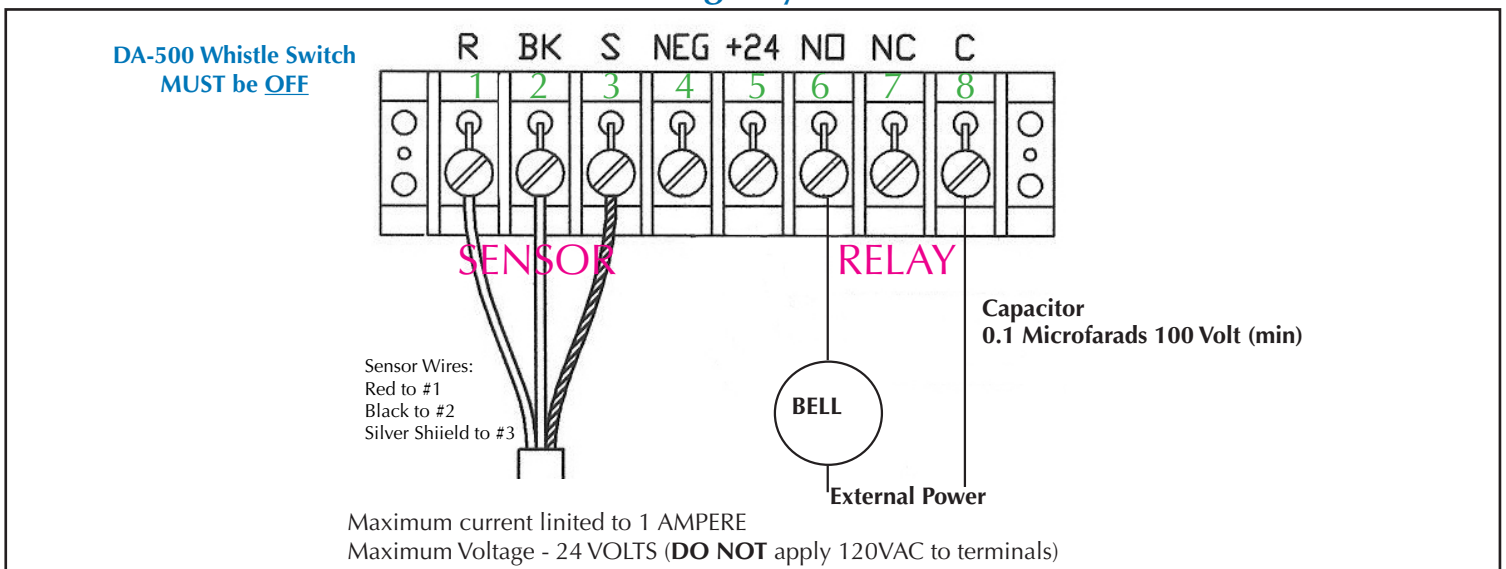

Accessories

WIRELESS DRIVE-ALERT ACCESSORIES:



DA-066MP DA-078 DA-100CP DA-REPEATER DA-606 DA-071 DA-072 DA-073 DA-ROCK1

- The **DA-066MP Remote Chime Transmitter** is used in combination with the wireless **DA-078 Remote Plug-in Chime(s)** in applications where more chimes are wanted in more rooms/areas. Unlimited quantities may be used.
- The **DA-100CP Long Distance Remote Chime** is actually a self-contained Control Panel/Receiver that receives a signal from up to 1000 feet of any of Mier's wireless Sensor/Transmitters, or a DA-REPEATER, and provides a pleasant tone as an alert. It also includes volume control.
- The **DA-REPEATER** can be attached to a DA-700 or DA-500 Control Panel/Receiver and repeats the signal to other wireless Control Panel/Receivers (DA-100CP, DA-700CP) up to 1000 feet away, or up to 3/4-mile with the use of a DA-660 Antenna (see previous page).
- The **DA-606LK Wireless Light Kit** comes with a **DA-606 Timer Control**, one **DA-071 Light-Switch**, and one **DA-072 Lamp Module**. Any number and combination of light-switches and lamp modules may be used. For heavy-duty applications the **DA-073 Heavy-Duty Outlet** includes a top receptacle that handles up to a maximum of 1800 watts or maximum of 15 amps.
- The **DA-ROCK1** is a popular accessory with all of our wireless systems, and is used to hide the DA-610 Sensor

HARD-WIRED DRIVE-ALERT ACCESSORIES:



DA-655 DA-500LKA DA-052V DA-505 DA-505W DA-050

- The **Hard-Wired DA-655 Chime with Volume Control** is our most popular accessory for the model DA-500 Drive-Alert in Drive-up Window or business applications!
- The **DA-500LKA** is a set of Form C Dry Contacts that can be attached to the DA-700 or DA-500 Control Panels.
- The **DA-052V Whistle with Volume Control** – is used with the DA-700 when a second whistle is desired (hard-wired installation)
- The **Hard-Wired DA-505 Timer Control** will turn on 10 amps of lights, sirens or bells from 1-45 minutes. The DA-505 unit simply plugs into a 120 VAC outlet and contains its own receptacle to provide power to lights or alarms.
- The **Hard-Wired DA-505 Timer Control** will turn on lights, sirens or bells from 1-45 minutes. The DA-505W is a “stand alone” unit that gets its power from the Drive-Alert, and provides a N.O., timed, dry contact to switch a load (lights, contactors, bells, etc) rated at 10 amps, 120 volts AC. The DA-505W is a terrific intermediate interface with a “healthy” large relay within, that may be used to control other functions such as triggering a large commercial lighting contactor, billboards, holiday lights, etc.
- The **DA-050 Power Pack** is a replacement power-pack/transformer for the Drive-Alerts.

If your Drive-Alert accessories do not look like these, you may have older models. Please call Mier's free tech support line at 800-473-0213

DA-500 Drive-Alert Frequently Asked Questions

Q: How many Sensor/Transmitters can be used?

A: Three hard-cabled sensors. However there is no way to discriminate which Sensor/Transmitter is causing the alert to sound.

Q: How many sound devices can be used?

A: See the following list and quantities supported:

•DA-063 8 inch Bell	QTY 2
•DA-052V Hard-Wired Remote Whistle	QTY 5
•DA-078 Wireless Plug-InChime	QTY Unlimited
•DA-071 Wireless Light Switch	QTY Unlimited
•DA-072 Wireless Lamp Module	QTY Unlimited
•DA-655 Wired Chime	QTY 3, with a maximum of 50 feet of wire
•Miscellaneous Sounder	QTY # That adds to 100mA(max) load

Q: Does the unit have the capability when it determines an alarm is to be sounded, to trigger another device.

A: Each unit DOES have this capability as the 3 contacts from the alarm relay are available for use at the Terminal Block (Terminals 6-8). In models that DO have an internal Whistle and corresponding switch these contacts normally switch +24 Volts but can become Form C dry contacts when the Whistle Switch is in the OFF position. In those models that DO NOT have an internal Whistle, and corresponding switch, these contacts will always be switching +24 Volts.

Q: Can a camera be activated by the Drive Alert.

A; Yes, by using the Form C dry contact mode or by buffering with an external relay in the non-dry contact mode.

Q: Can a gate be activated by the Drive Alert.

A: Yes, by using the Form C dry contact mode or by buffering with an external relay in the non-dry contact mode but safety care should be taken for the event a person or vehicle in the gate's path.

Q: Can vehicles be counted using the Drive Alert.

A: Yes, by using the Form C dry contact mode or by buffering with an external relay in the non-dry contact mode.

Q: Can the Drive Alert provide a contact closure for detection to open/lift an arm and then close it when the vehicle has cleared the area.

A: No, it does not provide intelligence beyond the simple sensing that the magnetic field has been disturbed. Once disturbed a closure occurs for a user defined time up to 12 seconds at which time the gate or arm will then return to its home position. For these types of functions external logic and timing is required.

Q: Can the Drive Alert sense which way the vehicle is traveling?

A: No, it does not include this capability and would require either external methods or the use of two systems and most likely external logic to sequence the two systems for this determination.

Q: How can I determine if something NOT a magnetic metal is moving?

A: Within the range of the sensor, attach a magnet or a metal that has magnetic characteristics such as steel. Now whenever it moves the sensor senses it, transmits to the Receiver/Control Panel and the alarm is set off.

Q: Does the Drive Alert sense people?

A: No, it doesn't sense people or animals, only changes that result in a magnetic field disturbance. IF detecting people or animals is needed with a Drive Alert, then a magnet or significant magnetic metal must be on the person/animal.



DA-500 Drive-Alert Troubleshooting Tree

- Step 1 - Check to make sure the Power Light is on. If not, replace the internal 1A fuse, or send to Mier Products for repair.
 Step 2 - Make sure the sensor is attached correctly and securely to the control panel.
 Step 3 - Make sure the sensor is located close enough to detect moving vehicles.
 Step 4 - Make sure the sensor is at least 20 feet away from underground or overhead power/phone lines or an invisible fence, and the control panel is at least 15 feet away from cellular or cordless phones, wireless routers, etc.
 Step 5 - Make sure the sensor is at least 50 feet away from the street/road traffic to prevent false alarms.
 Step 6 - Make sure there are no nicks or cuts in the cable allowing moisture to get inside and cause false alarms.

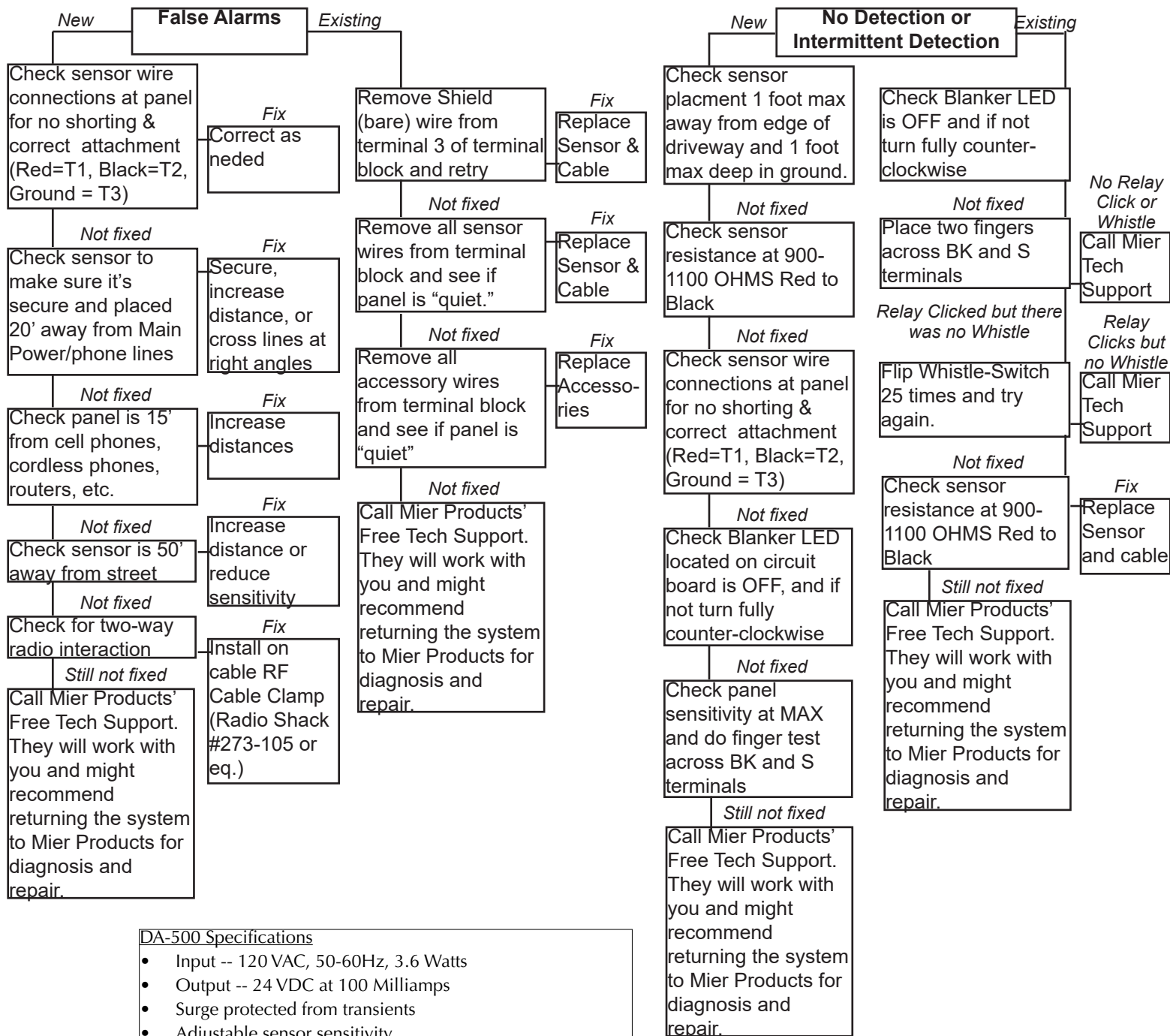

- DA-500 Specifications**
- Input -- 120 VAC, 50-60Hz, 3.6 Watts
 - Output -- 24 VDC at 100 Milliamps
 - Surge protected from transients
 - Adjustable sensor sensitivity
 - Adjustable time control for electronic whistle
 - Operating temperature -- 20 degree F to 160 degree F
 - Provisions for activating optional timer control
 - Weight -- six (6) pounds

Mier Products' Drive-Alert Technical Support

Mier Products, Inc. provides **free telephone and email lifetime technical support** for all of our Drive-Alert vehicle detection systems. Call us between the hours of 8:00 am and 5:00 pm EST, send an email, or download our Cut-Sheets, Instruction Manuals, or FAQs from our website.
800-473-0213 ~ info@mierproducts.com ~ www.mierproducts.com

Mier Products' Drive-Alert Warranty

Limited Warranty for Drive-Alert Models and Accessories Manufactured by Mier Products, Inc.

Mier Products, Inc.'s Limited Warranty Program for Drive-Alert Series of Vehicle Detection Systems and Drive-Alert Accessories protects the original owner for one year from the date of purchase against defects in original parts or workmanship. Mier Products, Inc. agrees to repair or replace parts (Mier's option) that are deemed defective by our Quality Control Team, without charge for parts or labor, if the defective unit is returned prepaid to Mier Products, Inc., Kokomo, IN, within the one-year period.

Close inspection and testing, at the time of receipt by the customer, will quickly determine product quality. Thus, Mier Products, Inc. recommends inspection of, and testing, the Drive-Alert models, direct burial cable, and accessories immediately upon receipt, *before installation or driving to an installation site*, and contacting Mier Products, Inc. if quality issues arise.

NOTE: Sensors and cables that have been buried are not covered. Wireless sensors that have been sitting in flooded areas or standing water are not covered.

Mier Products, Inc. does not assume responsibility for claims or damages caused by improper installation or use of these products, accessories, and/or products connected to or stored within them. Mier Products, Inc. does not assume responsibility for damages to these products or their accessories due to shipping damage or damage occurring while in a customer's warehouse and/or possession. Mier Products, Inc. does not assume responsibility for damage due to accident, faulty wiring, overload of Drive-Alert System or Drive-Alert accessory output, or components attached to the Drive-Alert parts. Drive-Alert models and accessories must be shipped, handled, stored, and installed with strict adherence to OEM installation instructions.

Drive-Alert accessories and parts built by other OEMs (including but not limited to chimes, lamp modules, light switches, bells, splice kits) are covered under their respective OEM warranties.

This warranty constitutes the entire warranty with respect to Mier's Drive-Alert Models and Accessories and IS IN LIEU OF ALL OTHERS, EXPRESSED OR IMPLIED, INCLUDING ANY WARRANTY OR MERCHANTABILITY AND WARRANTY OF FITNESS FOR A PARTICULAR PURPOSE AND IN NO EVENT IS MIER PRODUCTS, INC., OR IT'S DISTRIBUTOR, DEALER, OR OEM PARTNERS, RESPONSIBLE FOR ANY CONSEQUENTIAL DAMAGES OF ANY NATURE WHATSOEVER.

Any warranty OR sales questions should be directed to Mier Products at 800-473-0213, or via e-mail to info@mierproducts.com

Any repair work not covered by this Warranty is available for a nominal charge.

Products which customers wish to return for reasons other than Warranty must first call Mier Products, Inc. to receive a Return Material Authorization Number (RMA#). Returns are subject to a 15% re-stocking fee as well as return shipping. NOTE: Special Order products, such as Mier's Temperature Controlled Enclosure line, are non-cancellable and non-returnable.

