

Keystone Industrial DIN-Rail Mounting Module



Signamax Keystone Industrial DIN-Rail Mounting Modules afford an opportunity to combine advantages of regular keystone jack design and transmission performance with simplicity and usability of industrial DIN-rail mounting systems.

State-of-the-art module's design provides all kinds of features usually found in office work area solutions, – universal labeling, protection covers, "front access," "gravity compensation" for patch cords along with such important for the industrial applications aspects as toolless mounting and replacement of connector modules, quick access to any part of the assembly. Additionally, modules allow installing screened jacks without any extra efforts, parts, and tools.

KEY FEATURES

- Designed for standard 35-mm wide DIN rails ❶
- Side lids ❷ are removable facilitating installation of several modules in one continuous row ❸
- Accommodates all Signamax keystone jacks up to 17 mm (0.67 in) wide
- Bronze alloy spring ❹ serves two purposes – secure retention of all keystone jack types, and grounding contact and path for screened jacks
- Clear plastic labeling window ❺
- Front hinged hatch ❻ protects keystone jack from damage and contamination when it is not used
- Swinging cassette with latching mechanism ❼ allows quick and easy installation and removal of the keystone jack
- Installation does not require special tools or threaded fastening – the module snaps-on the DIN rail ❸
- Cable entry points are equipped with noses ❾ supporting required cable bend radii and protecting cables from deformation
- Equipment or patch cord connection angle provides for cord stress compensation caused by the cord's weight

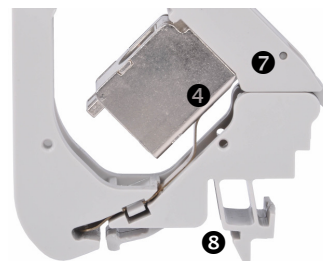
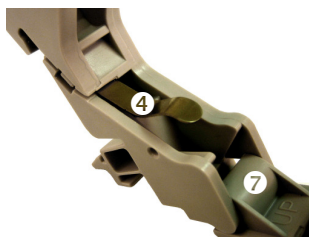
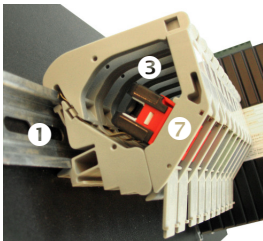
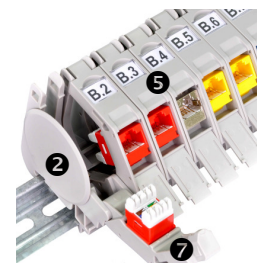
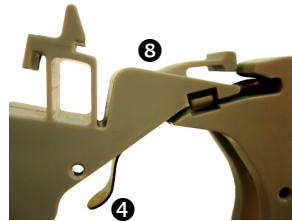
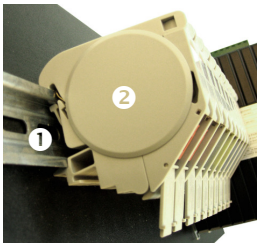
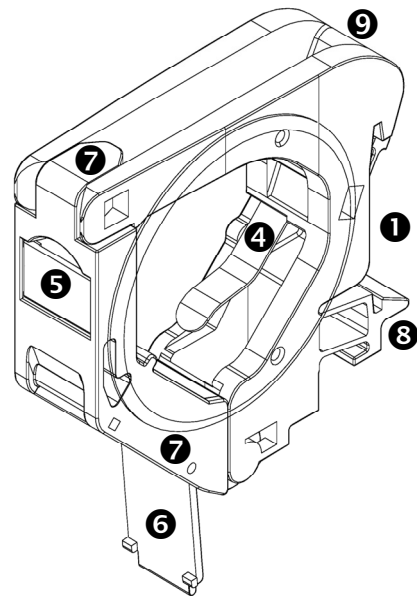

Keystone Industrial DIN-Rail Mounting Module

ORDERING INFORMATION

Keystone Industrial DIN-Rail Mounting Modules

Part Number	Description
-------------	-------------

KI-DIN-RMM-SL	Keystone Industrial DIN-Rail Mounting Module, 2 Side Lids
KI-DIN-RMM	Keystone Industrial DIN-Rail Mounting Module, w/o Side Lids

Standard color is Gray

SPECIFICATIONS

• CONSTRUCTION

Housing: high impact thermoplastic, UL94V-0 fire retardant
Jack spring wire: bronze alloy

• MECHANICAL

DIN rail: 35 mm (1.378 in)
Keystone module width: 17 mm (0.669 in) max

• MOUNTING DIMENSIONS:

KI-DIN-RMM-SL:
D 67.5 mm H 70.5 mm W 21.0 mm
D 2.66 in H 2.78 in W 0.83 in

KI-DIN-RMM:
D 67.50 mm H 70.50 mm W 18.0 mm
D 2.66 in H 2.78 in W 0.71 in

• ENVIRONMENTAL CONDITIONS

Storage: -40°C – +70°C (-40°F – +158°F)
Operation: -10°C – +60°C (+14°F – +140°F)
RH (operation): max non-condensing 93%

• COMPATIBILITY

Signamax MT-series unscreened keystone jacks
Signamax TL-series screened keystone jacks
Signamax KRJ45/xS unscreened feed-thru couplers

RELATED PRODUCTS

Product/Product Group	Spec Sheet #
Voice-Grade Unscreened High-Density MT-Series Keystone Jack _____	PSS.KJ126MT-C3U (B-OCT-11)
Category 5e Unscreened High-Density MT-Series Keystone Jack _____	PSS.KJ458MT-C5E (B-OCT-11)
Category 5e Screened Toolless Keystone Jack _____	PSS.KJS458TL-C5E (A-JUN-10)
Category 6 Unscreened High-Density MT-Series Keystone Jack _____	PSS.KJ458MT-C6C (B-OCT-11)
Category 6 Screened Toolless Keystone Jack _____	PSS.KJS458TL-C6C (A-JUN-10)
Category 6A Unscreened High-Density MT-Series Keystone Jack _____	PSS.KJ458MT-C6AC (A-JUL-10)
Category 6A Screened Toolless Keystone Jack _____	PSS.KJS458TL-C6AC (A-JUL-10)
Category 6 Keystone Feed-Thru Couplers _____	PSS.C6SL-KFTC (A-OCT-08)

SPECIFICATIONS