

HPFF8(E)/HPFF8CM(E)

Notification Appliance Circuit Expander
Instruction Manual

Fire Alarm & Emergency Communication System Limitations

While a life safety system may lower insurance rates, it is not a substitute for life and property insurance!

An automatic fire alarm system—typically made up of smoke detectors, heat detectors, manual pull stations, audible warning devices, and a fire alarm control panel (FACP) with remote notification capability—can provide early warning of a developing fire. Such a system, however, does not assure protection against property damage or loss of life resulting from a fire.

An emergency communication system—typically made up of an automatic fire alarm system (as described above) and a life safety communication system that may include an autonomous control unit (ACU), local operating console (LOC), voice communication, and other various interoperable communication methods—can broadcast a mass notification message. Such a system, however, does not assure protection against property damage or loss of life resulting from a fire or life safety event.

The Manufacturer recommends that smoke and/or heat detectors be located throughout a protected premises following the recommendations of the current edition of the National Fire Protection Association Standard 72 (NFPA 72), manufacturer's recommendations, State and local codes, and the recommendations contained in the Guide for Proper Use of System Smoke Detectors, which is made available at no charge to all installing dealers. This document can be found at <http://www.systemsensor.com/appguides/>. A study by the Federal Emergency Management Agency (an agency of the United States government) indicated that smoke detectors may not go off in as many as 35% of all fires. While fire alarm systems are designed to provide early warning against fire, they do not guarantee warning or protection against fire. A fire alarm system may not provide timely or adequate warning, or simply may not function, for a variety of reasons:

Smoke detectors may not sense fire where smoke cannot reach the detectors such as in chimneys, in or behind walls, on roofs, or on the other side of closed doors. Smoke detectors also may not sense a fire on another level or floor of a building. A second-floor detector, for example, may not sense a first-floor or basement fire.

Particles of combustion or "smoke" from a developing fire may not reach the sensing chambers of smoke detectors because:

- Barriers such as closed or partially closed doors, walls, chimneys, even wet or humid areas may inhibit particle or smoke flow.
- Smoke particles may become "cold," stratify, and not reach the ceiling or upper walls where detectors are located.
- Smoke particles may be blown away from detectors by air outlets, such as air conditioning vents.
- Smoke particles may be drawn into air returns before reaching the detector.

The amount of "smoke" present may be insufficient to alarm smoke detectors. Smoke detectors are designed to alarm at various levels of smoke density. If such density levels are not created by a developing fire at the location of detectors, the detectors will not go into alarm.

Smoke detectors, even when working properly, have sensing limitations. Detectors that have photoelectronic sensing chambers tend to detect smoldering fires better than flaming fires, which have little visible smoke. Detectors that have ionizing-type sensing chambers tend to detect fast-flaming fires better than smoldering fires.

Because fires develop in different ways and are often unpredictable in their growth, neither type of detector is necessarily best and a given type of detector may not provide adequate warning of a fire.

Smoke detectors cannot be expected to provide adequate warning of fires caused by arson, children playing with matches (especially in bedrooms), smoking in bed, and violent explosions (caused by escaping gas, improper storage of flammable materials, etc.).

Heat detectors do not sense particles of combustion and alarm only when heat on their sensors increases at a predetermined rate or reaches a predetermined level. Rate-of-rise heat detectors may be subject to reduced sensitivity over time. For this reason, the rate-of-rise feature of each detector should be tested at least once per year by a qualified fire protection specialist. Heat detectors are designed to protect property, not life.

IMPORTANT! Smoke detectors must be installed in the same room as the control panel and in rooms used by the system for the connection of alarm transmission wiring, communications, signaling, and/or power. If detectors are not so located, a developing fire may damage the alarm system, compromising its ability to report a fire.

Audible warning devices such as bells, horns, strobes, speakers and displays may not alert people if these devices are located on the other side of closed or partly open doors or are located on another floor of a building. Any warning device may fail to alert people with a disability or those who have recently consumed drugs, alcohol, or medication. Please note that:

- An emergency communication system may take priority over a fire alarm system in the event of a life safety emergency.
- Voice messaging systems must be designed to meet intelligibility requirements as defined by NFPA, local codes, and Authorities Having Jurisdiction (AHJ).
- Language and instructional requirements must be clearly disseminated on any local displays.
- Strobes can, under certain circumstances, cause seizures in people with conditions such as epilepsy.
- Studies have shown that certain people, even when they hear a fire alarm signal, do not respond to or comprehend the meaning of the signal. Audible devices, such as horns and bells, can have different tonal patterns and frequencies. It is the property owner's responsibility to conduct fire drills and other training exercises to make people aware of fire alarm signals and instruct them on the proper reaction to alarm signals.
- In rare instances, the sounding of a warning device can cause temporary or permanent hearing loss.

A life safety system will not operate without any electrical power. If AC power fails, the system will operate from standby batteries only for a specified time and only if the batteries have been properly maintained and replaced regularly.

Equipment used in the system may not be technically compatible with the control panel. It is essential to use only equipment listed for service with your control panel.

Telephone lines needed to transmit alarm signals from a premises to a central monitoring station may be out of service or temporarily disabled. For added protection against telephone line failure, backup radio transmission systems are recommended.

The most common cause of life safety system malfunction is inadequate maintenance. To keep the entire life safety system in excellent working order, ongoing maintenance is required per the manufacturer's recommendations, and UL and NFPA standards. At a minimum, the requirements of NFPA 72 shall be followed. Environments with large amounts of dust, dirt, or high air velocity require more frequent maintenance. A maintenance agreement should be arranged through the local manufacturer's representative. Maintenance should be scheduled as required by National and/or local fire codes and should be performed by authorized professional life safety system installers only. Adequate written records of all inspections should be kept.

Limit-D2-2016

Installation Precautions

Adherence to the following will aid in problem-free installation with long-term reliability:

WARNING - Several different sources of power can be connected to the fire alarm control panel. Disconnect all sources of power before servicing. Control unit and associated equipment may be damaged by removing and/or inserting cards, modules, or interconnecting cables while the unit is energized. Do not attempt to install, service, or operate this unit until manuals are read and understood.

CAUTION - System Re-acceptance Test after Software

Changes: To ensure proper system operation, this product must be tested in accordance with NFPA 72 after any programming operation or change in site-specific software. Re-acceptance testing is required after any change, addition or deletion of system components, or after any modification, repair or adjustment to system hardware or wiring. All components, circuits, system operations, or software functions known to be affected by a change must be 100% tested. In addition, to ensure that other operations are not inadvertently affected, at least 10% of initiating devices that are not directly affected by the change, up to a maximum of 50 devices, must also be tested and proper system operation verified.

This system meets NFPA requirements for operation at 0-49° C/ 32-120° F and at a relative humidity . However, the useful life of the system's standby batteries and the electronic components may be adversely affected by extreme temperature ranges and humidity. Therefore, it is recommended that this system and its peripherals be installed in an environment with a normal room temperature of 15-27° C/60-80° F.

Verify that wire sizes are adequate for all initiating and indicating device loops. Most devices cannot tolerate more than a 10% I.R. drop from the specified device voltage.

Like all solid state electronic devices, this system may operate erratically or can be damaged when subjected to lightning induced transients. Although no system is completely immune from lightning transients and interference, proper grounding will reduce susceptibility. Overhead or outside aerial wiring is not recommended, due to an increased susceptibility to nearby lightning strikes. Consult with the Technical Services Department if any problems are anticipated or encountered.

Disconnect AC power and batteries prior to removing or inserting circuit boards. Failure to do so can damage circuits.

Remove all electronic assemblies prior to any drilling, filing, reaming, or punching of the enclosure. When possible, make all cable entries from the sides or rear. Before making modifications, verify that they will not interfere with battery, transformer, or printed circuit board location.

Do not tighten screw terminals more than 9 in-lbs. Over-tightening may damage threads, resulting in reduced terminal contact pressure and difficulty with screw terminal removal.

This system contains static-sensitive components. Always ground yourself with a proper wrist strap before handling any circuits so that static charges are removed from the body. Use static suppressive packaging to protect electronic assemblies removed from the unit.

Follow the instructions in the installation, operating, and programming manuals. These instructions must be followed to avoid damage to the control panel and associated equipment. FACP operation and reliability depend upon proper installation.

Precau-D1-9-2005

FCC Warning

WARNING: This equipment generates, uses, and can radiate radio frequency energy and if not installed and used in accordance with the instruction manual may cause interference to radio communications. It has been tested and found to comply with the limits for class A computing devices pursuant to Subpart B of Part 15 of FCC Rules, which is designed to provide reasonable protection against such interference when devices are operated in a commercial environment. Operation of this equipment in a residential area is likely to cause interference, in which case the user will be required to correct the interference at his or her own expense.

Canadian Requirements

This digital apparatus does not exceed the Class A limits for radiation noise emissions from digital apparatus set out in the Radio Interference Regulations of the Canadian Department of Communications.

Le présent appareil numérique n'émet pas de bruits radioélectriques dépassant les limites applicables aux appareils numériques de la classe A prescrites dans le Règlement sur le brouillage radioélectrique édicté par le ministère des Communications du Canada.

HARSH™, NIS™, and NOTI-FIRE-NET™ are all trademarks; and Acclimate®, FlashScan®, Honeywell®, NOTIFIER®, ONYX®, ONYXWorks®, VeriFire®, and VIEW® are all registered trademarks of Honeywell International Inc. Microsoft® and Windows® are registered trademarks of the Microsoft Corporation. Chrome™ and Google™ are trademarks of Google Inc. Firefox® is a registered trademark of The Mozilla Foundation.

©2018 by Honeywell International Inc. All rights reserved. Unauthorized use of this document is strictly prohibited.

Software Downloads

In order to supply the latest features and functionality in fire alarm and life safety technology to our customers, we make frequent upgrades to the embedded software in our products. To ensure that you are installing and programming the latest features, we strongly recommend that you download the most current version of software for each product prior to commissioning any system. Contact Technical Support with any questions about software and the appropriate version for a specific application.

Documentation Feedback

Your feedback helps us keep our documentation up-to-date and accurate. If you have any comments or suggestions about our online Help or printed manuals, you can email us.

Please include the following information:

- Product name and version number (if applicable)
- Printed manual or online Help
- Topic Title (for online Help)
- Page number (for printed manual)
- Brief description of content you think should be improved or corrected
- Your suggestion for how to correct/improve documentation

Send email messages to:

FireSystems.TechPubs@honeywell.com

Please note this email address is for documentation feedback only. If you have any technical issues, please contact Technical Services.

Table of Contents

Section 1: System Overview	8
1.1: General	8
1.2: Features	8
1.3: Start-up Procedure	9
1.4: Jumpers	9
1.4.1: Charger Disable Jumper (J1)	10
1.4.2: Ground Fault Disable Jumper (J2)	10
1.5: LED Indicators	10
1.6: Specifications	10
Section 2: Installation	13
2.1: Backbox Mounting	13
2.2: Chassis-Mounting in FACP Cabinets	16
2.3: Chassis-mounting in CAB-4 and EQ Cabinets	17
2.3.1: CAB-4 Series Equipment Cabinets	17
2.3.2: EQ Series Equipment Cabinets	18
2.4: NAC Circuit Wiring	19
2.4.1: Four NACs Configured for Class B (Style Y)	19
2.4.2: Two NACs Configured for Class A (Style Z)	20
2.4.3: Mixing Class B and Class A NACs	21
2.4.4: HPP31076 Optional Class A (Style Z) Adapter	21
2.5: Mounting Addressable Modules	22
2.5.1: Mounting Modules from Honeywell Fire Systems	23
2.5.2: Mounting Six-Circuit Modules from Honeywell Fire Systems	24
2.6: Power-Limited Wiring Requirements	24
2.6.1: Power-Limited Wiring, Standard Chassis	25
2.6.2: Power-Limited Wiring, FACP Cabinet	26
Section 3: Programming Options	28
3.1: DIP Switch Settings	28
3.2: Programmable Features	29
3.2.1: Input/Output Functions	29
3.2.2: Synchronization Type	29
3.2.3: Trouble Reporting Delay with an AC Failure	29
3.2.4: Split Alarm and Silencing	30
Section 4: Trouble Supervision	31
4.1: Supervised Functions and Field Wiring	31
4.2: Trouble Reporting	31
4.2.1: Normal/Standby	31
4.2.2: Alarm	32
4.2.3: TB2: AC FAIL Contacts	32
4.2.4: TB2: TROUBLE Contacts	32
4.2.5: TB3: Initiating Device Inputs SIGNAL 1 and SIGNAL 2	32
4.2.6: Trouble Memory	32
4.2.7: Ground Fault Detection	33
4.2.8: NAC Overload Protection and Indication	33
Section 5: Applications	35
5.1: Controlling Four NAC Circuits from a Single Source	35
5.2: Controlling and Silencing Four NACs	36
5.3: Split Alarm and Selective Silence	37
5.3.1: Selective Silence	37
5.3.2: Split Alarm Mode	38
5.4: Connecting Multiple Units	39
Section 6: Power Supply Requirements	42
6.1: Overview	42
6.2: Calculating the AC Branch Circuit Current	42
6.3: Calculating the System Current Draw	42
6.3.1: Overview	42
6.3.2: How to Calculate System Current Draw	43
6.4: Calculating the Battery Size	44

6.4.1: NFPA Battery Requirements	44
6.4.2: Selecting and Locating Batteries	44
6.5: NAC Circuit Loop Wiring Requirements	44
Index	45

It is imperative that the installer understand the requirements of the Authority Having Jurisdiction (AHJ) and be familiar with the standards set forth by the following regulatory agencies:

- Underwriters Laboratories Standards
- NFPA 72 National Fire Alarm Code

Before proceeding, the installer should be familiar with the following documents.



NFPA Standards

NFPA 72 National Fire Alarm Code
NFPA 70 National Electrical Code



Underwriters Laboratories Documents:

UL 464 Audible Signaling Appliances
UL 864 Standard for Control Units for Fire Protective Signaling Systems
UL 1638 Visual Signaling Appliances
UL 1971 Signaling Devices for Hearing Impaired

Other:

NEC Article 250 Grounding
NEC Article 300 Wiring Methods
NEC Article 760 Fire Protective Signaling Systems
Applicable Local and State Building Codes
Requirements of the Local Authority Having Jurisdiction (LAHJ)

HPP Documents:

HPP Device Compatibility
HPFF12(E)/HPFF12CM(E) NAC Expander
HPP31076 Optional Class A (Style Z) Adapter

Document #54399
Document #53576
Document #53728

This product has been certified to comply with the requirements in the Standard for Control Units and Accessories for Fire Alarm Systems, UL 864, 9th Edition. Operation of this product with products not tested for UL 864, 9th Edition has not been evaluated. Such operation requires the approval of the local Authority Having Jurisdiction (AHJ).

Section 1: System Overview

The Honeywell Power Products FireForce 8 (HPFF8) is one of the most innovative fire alarm remote power supplies available that complies with UL 864 9th Edition. Designed with advanced switch-mode power supply technology and built with the latest surface-mount electronic manufacturing techniques, it incorporates several new features that demanding installers requested to speed them through installation and servicing.

The HPFF8 is an 8.0 A power supply for Notification Appliance Circuit (NAC) expansion to support ADA requirements and strobe synchronization (sync). It provides filtered 24 VDC power to drive four NAC outputs. The four-output circuits may be configured as: four Class B (Style Y); two Class A (Style Z); two Class B and one Class A; or four Class A with the optional HPP31076 Class A adapter installed. The input circuits, which control the power supply operation, are triggered by the reverse polarity of a NAC or by the reverse polarity of a 12 VDC or 24 VDC power source. The power supplies are compatible with 12 VDC or 24 VDC control panels. They contain an internal battery charger capable of charging up to 26.0 AH (amp hour) batteries.

The HPFF8 models are wall cabinet units that can accommodate up to two 18 AH batteries. They can be configured to internally house one addressable control or relay module, a six-circuit relay module, or a six-circuit control module. (Modules are available through authorized Honeywell Fire Systems distributors.)

The HPFF8CM is a chassis-mount model that can fit two 12.0 AH batteries. It is a multi-pack option that allows up to four CM units to be mounted in a compatible Fire Alarm Control Panel (FACP) cabinet. These separately sold cabinets are also referred to as the large equipment enclosure. (*Equipment enclosures are available through authorized Honeywell Fire Systems distributors.*)

The HPFF8 and HPFF8CM power supply models operate at 120 VAC/60 Hz.

The HPFF8E and HPFF8CME power supply models are export units that operate at 240 VAC/50 Hz.

1.1 General

The HPFF8 power supplies are used as remotely mounted power supplies and battery chargers. The Fire Alarm Control Panel (FACP) or initiating device is connected to the input circuit(s). When the control input circuit activates due to the reverse polarity of the signal from the initiating device, the power supply will activate its NAC outputs.

During the inactive or non-alarm state, the power supply supervises its NAC field wiring independently for short and open conditions. If a NAC fault is detected, the power supply will open the initiating device input signal to notify the FACP and the Normally-Closed Trouble contact. If an AC loss is detected, the power supply will open the initiating device input signal, Normally-Closed Trouble, and a dedicated AC Fail contact.

If an alarm condition occurs and the NAC outputs are activated, the supervision and charger are disabled and the NAC circuit is no longer supervised (except for excessive loading or shorts). Supervision of other power supply faults such as battery voltage, AC loss, and ground fault will continue and may be monitored via Trouble contacts.

1.2 Features

- The enclosures offered are self-contained, lockable cabinets.
 - If the local Authority Having Jurisdiction (AHJ) requires the fire protection system to have matching locks, the units' locks may be swapped in the field to accommodate Honeywell Fire Systems branded panels: Honeywell, Notifier, Gamewell-FCI, Silent Knight, Farenhyt, and Fire-Lite Alarms.
- 24 VDC remote power supply
- Outputs are completely power-limited
- Four output circuits:
 - Fully filtered power
 - Four 24 VDC Class B (Style Y), or two Class A (Style Z), or two Class B (Style Y) and one Class A (Style Z) NACs (special application)
 - Four 24 VDC Class A (Style Z) NACs (special application) with optional HP31076 Class A adapter
- Status LED indicators on control PCB:
 - Power On LED
 - Auxiliary Trouble LED
 - Battery Trouble LED
 - Ground Fault LED
 - Individual NAC Trouble LEDs
- Maximum current for any one NAC output circuit: 3.0 A
- Maximum current for Auxiliary output circuit: 2.0 A
- Maximum total continuous current available: 8.0 A for HPFF8, HPFF8E, HPFF8CM, and HPFF8CME
- NAC overload protection and indication:
 - Shorted or excessively loaded NAC outputs automatically protect themselves
 - Status LEDs will illuminate steady to indicate the circuit affected
- Integral supervised battery charger:
 - Capable of charging 7.0 AH to 26.0 AH batteries
 - For lead-acid batteries only
 - Battery Trouble LED blinks to indicate charger fault
- Fully supervised power supply, battery, and NACs
- Two independent optically-isolated input/control circuits, compatible with 12 VDC and 24 VDC control panel NACs

- Selectable strobe synchronization for NACs compatible with System Sensor, Cooper Wheelock, Faraday, Amseco, and Gentex notification appliances
- Selectable pass-through (slave) or filtered input
 - Pass-through (slave) input of steady, coded audible, and synchronized strobe signals to NAC outputs
 - Filtered for full-wave-rectified polarity-reversing inputs or reducing spurious noise to generate steady-on NAC outputs
- Silenceable with two independent alarm inputs or by passed-through synchronization protocol
- Split Alarm mode allows a combination of coded signals outputs and Selectable Silence on NAC pairs
- Selectable silence with two independent alarm inputs and the HPFF programmed in Split Alarm mode
- End-of-line resistor compare:
 - Attach a single reference resistor to match value of the NAC end-of-line resistor (ELR)
 - Provides use of a wide range of ELR resistors' values: 1.9K ohms to 25K ohms
 - Eases retrofit installations by matching existing ELR value without having to locate in the field (ELRs must be UL Listed)
- NAC Trouble memory:
 - Individual NAC Trouble LEDs blink if past troubles occurred
 - Aids installer or repair personnel to find the location of past troubles
- Fixed, clamp-style terminal blocks to accommodate 12AWG (3.31 mm²) to 22 AWG (0.326 mm²) wire
- Separate Trouble and AC Fail Form-C relay contacts
- Initiating device input signal is interrupted for Trouble indication at device or FACP.
- Optional two-hour delay:
 - In opening of Trouble contacts upon AC loss (AC Fail contact always transfers immediately upon AC loss)
 - In interruption of initiating device input signal for Trouble indication at device or FACP
 - UL 864 9th Edition requires 1-3 hour delay, therefore always programming for the two-hour delay is recommended
- Auxiliary output:
 - Continuous 24 VDC output (even in alarm): 2.0 A
 - Resettable fuse (PTC) limited
- Mounting locations on the Control circuit board for optional addressable relay and control modules

1.3 Start-up Procedure

1. Configure the power supply jumpers as described in Section 1.4, “Jumpers”, on page 9.
2. Install the power supply as described in Section 2, “Installation”, on page 13.
3. Program the power supply as described in Section 3, “Programming Options”, on page 28.
4. Wire the power supply circuits, referring to the options described in Section 4, “Trouble Supervision”, on page 31 and the application examples in Section 5, “Applications”, on page 35.
5. Connect the primary source wiring while observing the following:
 - HPFF8 and HPFF8CM: make certain the primary source is 120 VAC, 60 Hz, 3.6 A.
 - HPFF8E and HPFF8CME: make certain the primary source is 240 VAC, 50 Hz, 2.1 A.
 - Run a pair of wires (with earth ground conductor) from the protected premises' main breaker box to TB1 on the internal 24 VDC power supply circuit board.
 - For power supplies: use 14 AWG (2.089 mm²) wire with 600 V insulation.
 - Connect ground of the protected premise to ground stud of the enclosure using a ring terminal and keps nuts supplied in the hardware kit. Refer to Figure 2.19 on page 27 for proper earth ground connections.



WARNING: DISCONNECT POWER

MAKE CERTAIN THAT THE AC CIRCUIT BREAKER IS OFF BEFORE MAKING ANY WIRING CONNECTIONS BETWEEN THE CIRCUIT BREAKER AND THE POWER SUPPLY.

6. Apply power to the power supply using the following procedure:
 - Apply AC power by turning on the AC mains circuit breaker connected to the power supply.
 - Connect a properly charged battery to the TB1 on the unit's internal Control circuit board.

1.4 Jumpers

The HPFF power supplies are comprised internally of two basic components: a 24 VDC power supply and a Control circuit board. The HPFF8 models have an installed 8.0 A power supply. Jumpers are located on the control circuit board; see Figure 1.1, “Control Circuit Board”.

1.4.1 Charger Disable Jumper (J1)

The HPFF power supplies' battery charger capacity is 26 AH maximum using the integral charger with a maximum charging rate of 0.75 A. The integral charger on the Control circuit board must be disabled in certain situations by removing the charger-disable jumper. One situation is when system requires a common battery set, as is possible in the large equipment enclosure. Another situation is if the system requires a larger battery capacity than the integral charger can charge in the proper time. Larger capacity batteries can be used if they are housed in an external UL-Listed enclosure, along with a UL-Listed battery charger that can restore the full charge to the batteries in the proper time.

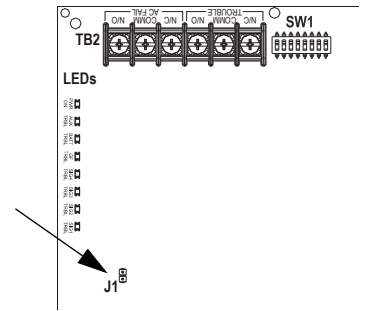

CAUTION: BATTERY CHARGER DISABLED

THE BATTERY CHARGER IS AUTOMATICALLY DISABLED DURING ALARM, SO BATTERIES WILL NOT BE CHARGED WHEN THE POWER SUPPLY IS IN THE ALARM STAGE.

Larger capacity batteries can be used if they are housed in an external UL-Listed enclosure, along with a UL-Listed battery charger suitable for fire alarm service and with sufficient capacity to restore the full charge in the required time. The alternate enclosure and battery charger shall be listed for Fire Protective Signaling use.

1.4.2 Ground Fault Disable Jumper (J2)

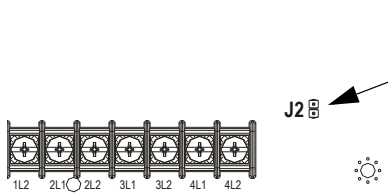

The Ground Fault detection circuit on the Control circuit board monitors the impedance from earth ground to any user wiring point, including +24 VDC. An exception is the initiating device signal inputs because they are optically-isolated from the rest of the circuitry and should be detected by the initiating device or FACP. Remove ground-fault disable jumper to disable the ground fault detection.

If the common circuitry of two or more HPFFs are connected together, or if the common of an HPFF is connected to the common of a system, such as a single battery connected to multiple units, then the ground fault jumpers must be removed from all but one of the units. The unit with the jumper installed provides the ground monitoring for

the whole system. If two or more units are connected together with ground fault monitoring enabled, then the monitoring circuits interfere with each other, and false ground faults will be generated.

1.5 LED Indicators

Indicator	Name	State	Trouble Condition
LED 1, 2, 3, 4	SIG(1, 2, 3, 4) TRBL	Blinking	NAC Trouble Memory
		Steady illumination	Open or shorted NAC
LED 5	GF TRBL	Steady illumination	An earth ground fault is present
LED 6	BAT TRBL	Blinking	Charger Fault
		Steady illumination	Low or missing battery
LED 7	AUX TRBL	Steady illumination	Excessive loading or shorted auxiliary output
LED 8	POWER ON	Blinking	Low (brownout) or missing AC input
		Steady illumination	Normal/Standby

Table 1.1 LED Indicators



NOTE: If all four SIG TRBL LEDs are illuminated steady, check if the reference ELR resistor is missing or doesn't match the ELR resistors used to terminate the Class B circuits. Otherwise, each NAC must have a trouble.

1.6 Specifications

Refer to Figure 1.1 and Figure 1.2 on page 12 for terminal locations.

Primary AC Power — TB1 (on 24 VDC power-supply circuit board)

- HPFF8 and HPFF8CM: 120 VAC, 60 Hz, 3.6 A
- HPFF8E and HPFF8CME: 240 VAC, 50 Hz, 2.1 A
- Wire size: 14AWG (2.08 mm²) with 600 V insulation

Initiating Device Signal Inputs — TB3 (on Control circuit board); terminals SIGNAL1: +IN, -IN, +OUT, -OUT, and SIGNAL2: +IN, -IN, +OUT, -OUT

- Supervised by FACP or initiating device, power-limited
- A supervisory relay must be used if initiating device is a power source

- Available for one of the following:
 - 4-wire inputs; or
 - 2-wire inputs and an ELR; or
 - facilitate multiple unit systems
- Trigger input voltage: 12 and 24 VDC
- Input trigger draw in alarm polarity:
 - 12 VDC, 5.68 mA maximum per input
 - 24 VDC, 12.26 mA maximum per input
- 12 AWG (3.31 mm²) to 18 AWG (0.821 mm²)

End-of-line Resistor Reference – TB3 (on Control circuit board); terminals REF+ and REF–

- Used for the ELR compare feature
- Range: 1.9K ohms to 25K ohms
- 12 AWG (3.31 mm²) to 22 AWG (0.326 mm²) with 600 V insulation

NAC Output Circuits — TB4 (on Control circuit board); terminals 1L1(+), 1L2(–), 2L1(+), 2L2(–), 3L1(+), 3L2(–), 4L1(+), and 4L2(–) — alarm polarity in parentheses (See page 11 for Auxiliary Input specifications on other TB4 terminals.)

- Supervised, special application, and power-limited
- Voltage rating: 24 VDC filtered
- Current:
 - Maximum for any one NAC circuit: 3.0 A
 - Maximum total continuous for all outputs: 8.0 A
- Output circuit types:
 - four Class B (Style Y); or
 - two Class A (Style Z);
 - two Class B (Style Y) and one Class A (Style Z) NACs; or
 - four Class A (Style Z) NACs with optional HPP31076 Class A adapter.
- 12 AWG (3.31 mm²) to 18 AWG (0.821 mm²).
- Refer to the *HPP Device Compatibility Document #54399* for listed compatible devices.

Trouble Contact Rating — TB2 (on Control circuit board); terminals TROUBLE: N/C, COM, and N/O (See below for other TB2 terminals.)

- Non-supervised
- Fail-safe Form-C relay
- Normally energized, transfers with NAC, battery, charger (in standby), AC loss, ground fault, and auxiliary output trouble
- 2.0 A @ 30 VDC
- AC loss trouble can be delayed for 2 hours (see Section 3, "Programming Options")
- 12 AWG (3.31 mm²) to 18 AWG (0.821 mm²)

AC Fail Contact Rating — TB2 (on Control circuit board); terminals AC FAIL: N/C, COM, N/O (See above for other TB4 terminals.)

- Non-supervised
- Fail-safe Form-C relay
- Normally energized, always transfers with AC loss
- 2.0 A @ 30 VDC
- 12 AWG (3.31 mm²) to 18 AWG (0.821 mm²)

Battery Charging Circuit — TB1 (on Control circuit board); terminals +BATT and –BATT

- Supervised, non-power-limited
- Supports lead-acid type batteries only
- Float charge voltage: 26.6 VDC
- Charger disabled if battery voltage falls below 15 VDC
- Maximum charge current: 0.75 A
- Battery fuse (F1): 15 A, 32 V
- Maximum battery capacity: 26.0 AH
- Minimum battery capacity: 7.0 AH
- Power supply draws a maximum standby current of 75 mA from batteries
- 12 AWG (3.31 mm²) to 18 AWG (0.821 mm²)

Auxiliary Output — TB4 (on Control circuit board); terminals +A and –A (See page 11 for NAC Output Circuits on other TB4 terminals.)

- Voltage checked for excessive loading, power limited (PTC), special application
- Voltage rating: 24 VDC continuous (even in alarm)
- Maximum for Auxiliary Output circuit: 2.0 A maximum (Subtract auxiliary load from total to determine available NAC load.)
- 12 AWG (3.31 mm²) to 18 AWG (0.821 mm²)
- For a list compatible optional modules that can be connected to the Auxiliary output, see the *HPP Device Compatibility Document #54399*.

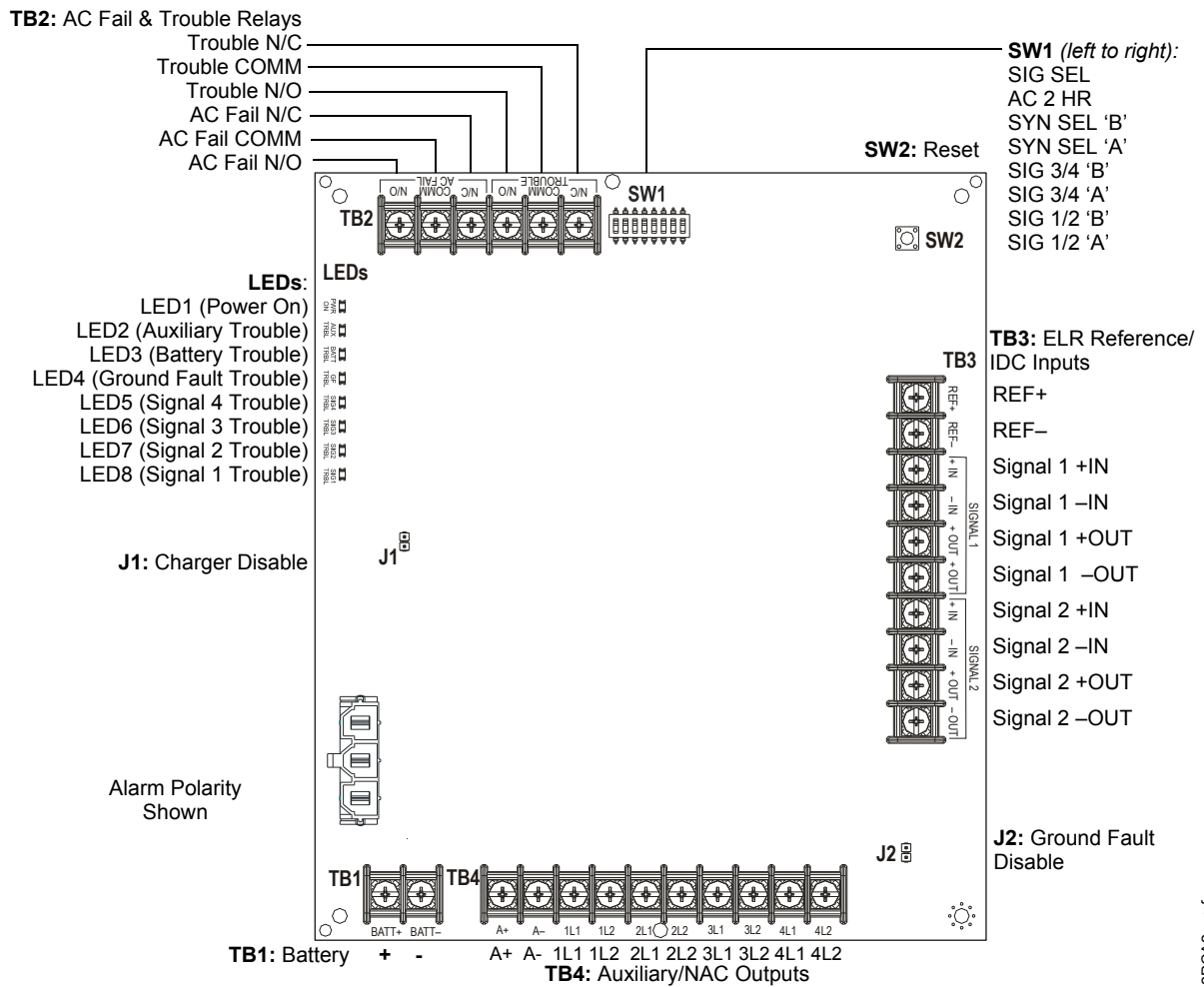

Figure 1.1 Control Circuit Board

HPFF812PCA2.wmf

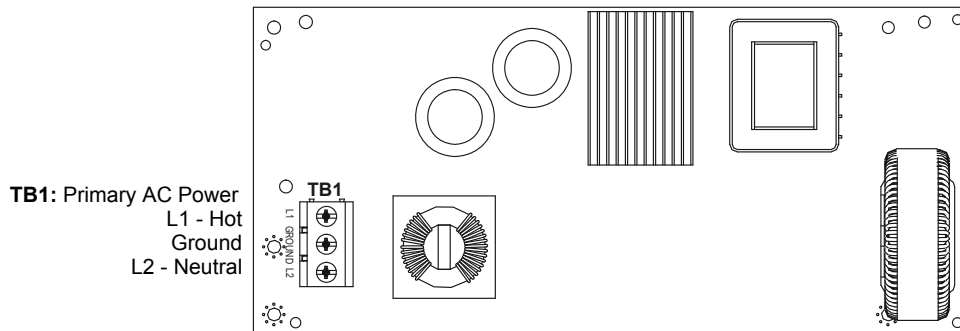

Figure 1.2 HPFF8 24 VDC Power Supply Circuit Board

FLPS-7b.wmf

Section 2: Installation

The standard cabinet may be either semi-flush or surface mounted. Fire Alarm Control Panel (FACP) cabinets can only be wall mounted. Each cabinet mounts using two or three key slots and two 0.250" (6.35 mm) diameter holes in the backbox. The key slots are located at the top of the backbox and the two securing holes at the bottom.

Carefully unpack the system and check for shipping damage. Mount the cabinet in a clean, dry, vibration-free area where extreme temperatures are not encountered. The area should be readily accessible with sufficient room to easily install and maintain the panel. Locate the top of the cabinet approximately 5 feet (1.5 m) above the floor with hinge mounting on the left. Determine the number of conductors required for the devices to be installed. Sufficient knockouts are provided for wiring convenience. Select the appropriate knockout(s) and pull the conductors into the box. All wiring should be in accordance with the National and/or Local codes for fire alarm systems and power supplies.

2.1 Backbox Mounting



CAUTION: STATIC SENSITIVE COMPONENTS

ALWAYS GROUND YOURSELF WITH A STATIC STRAP BEFORE HANDLING ANY BOARDS SO THAT THE STATIC CHARGES ARE REMOVED FROM THE BODY. USE STATIC SUPPRESSIVE PACKAGING TO PROTECT ELECTRONIC ASSEMBLIES.

To prevent damage to the circuit board and to facilitate backbox mounting, the chassis with the 24 VDC power supply and the Control circuit board can be easily removed. Loosen the two #8-32 nuts securing the top flanges of the chassis, then slide the chassis up to free it from the lower tabs. Place the chassis assembly in a safe location until it can be reinstalled in the backbox.

1. Mark and pre-drill a hole in the wall for the center top keyhole mounting bolt using the dimensions illustrated in Figure 2.2, "Standard Cabinet: Dimensions for Wall-mounting" on page 14 or Figure 2.3, "FACP Cabinet Mounting Details: Backbox-Mounting Holes and Chassis-Mounting Studs (EQBB-D4 shown)" on page 15.



NOTE: See the *CAB-4 Series Install Sheet* PN 15330 and *EQ Series Install Sheet* PN 53412 for door-mounting details and measurements for A-size, B-size, and D-size backboxes.

2. Install the center top fastener in the wall with screw head protruding.
3. Place backbox over the top screw, level and secure.
4. Mark and drill the left and right upper and lower mounting holes.
Note: outer holes (closest to sidewall) are used for 16" O.C. stud mounting.
5. Install remaining fasteners.

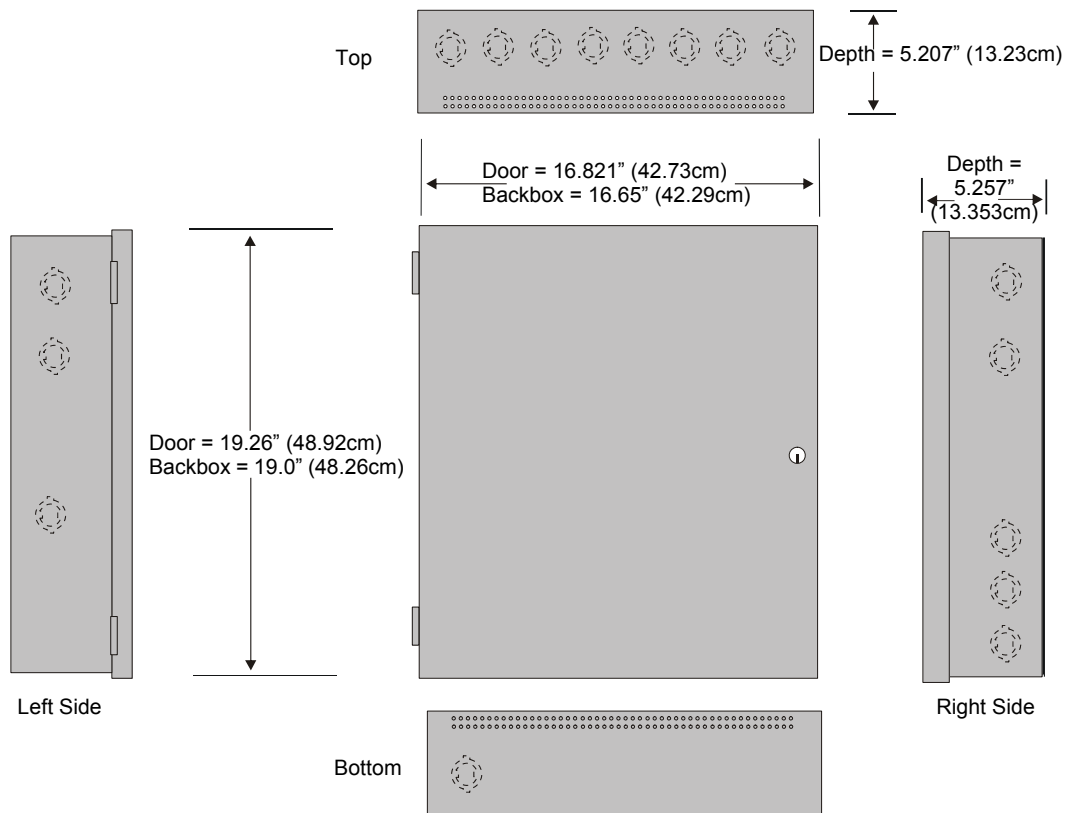

Figure 2.1 Standard Cabinet: Dimensions

ff8cab.vrnf

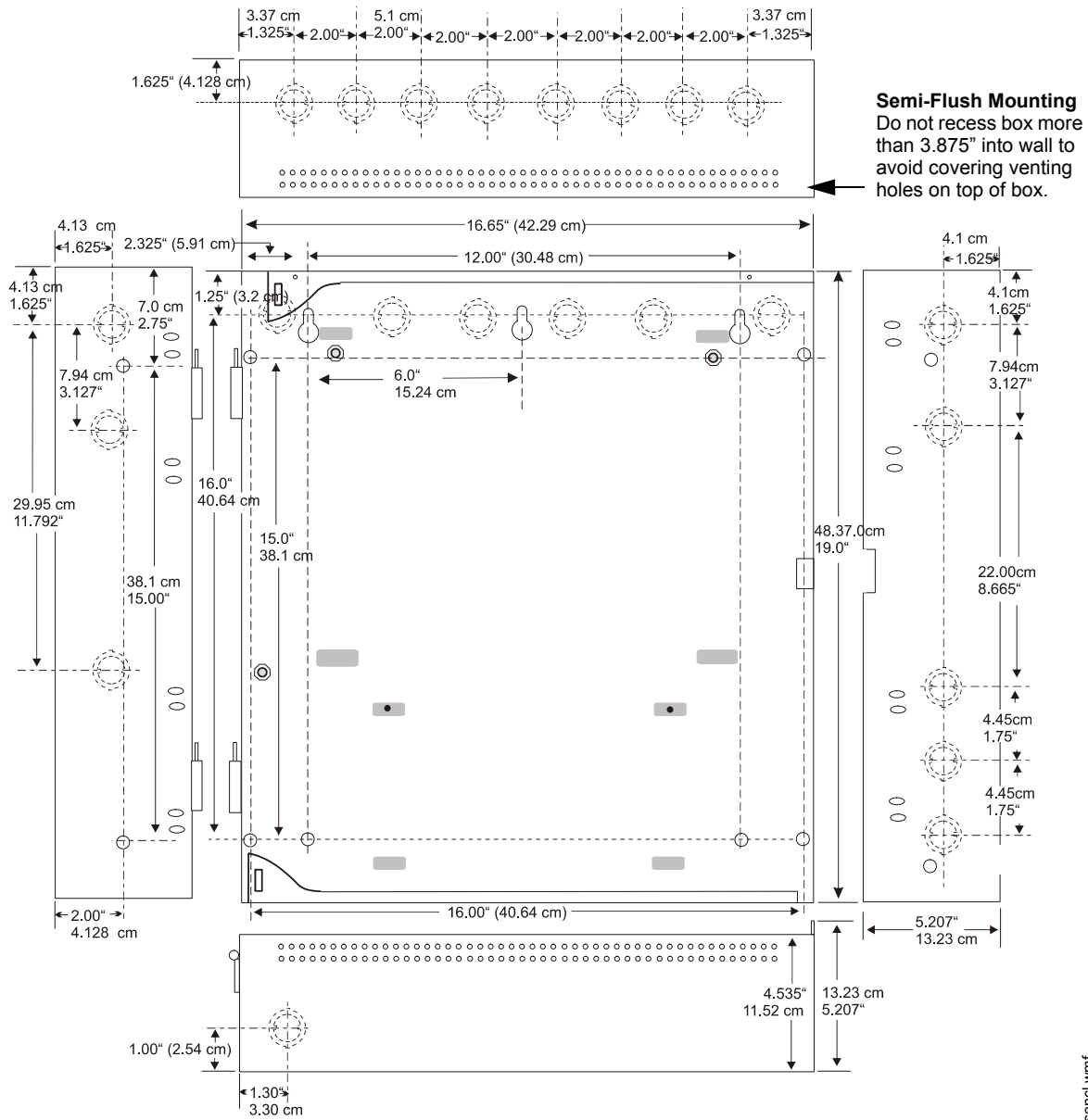
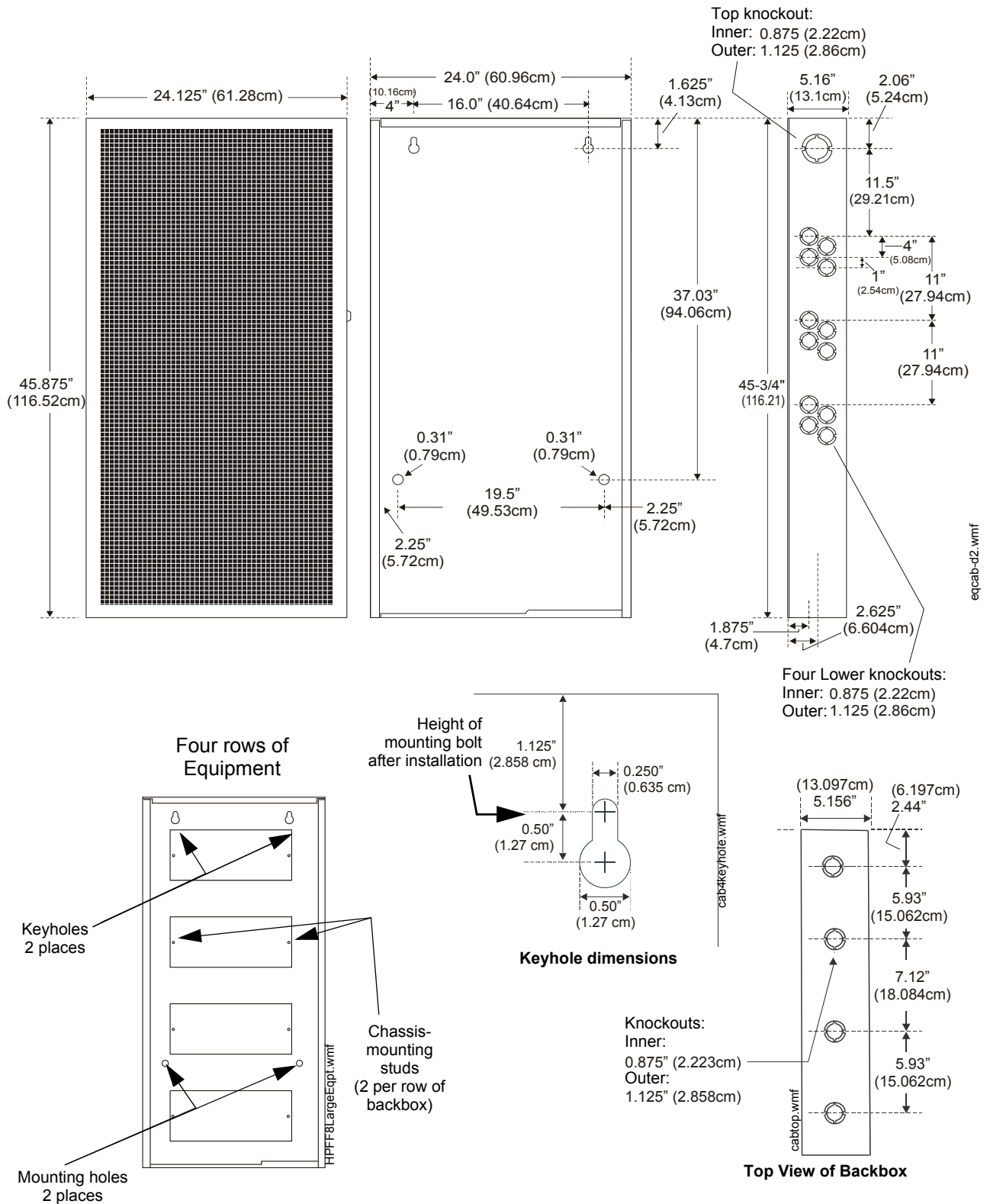

Figure 2.2 Standard Cabinet: Dimensions for Wall-mounting

92LudIsencI.wmf



NOTE: See CAB-4 Series Install Sheet PN 15330 and EQ Series Install Sheet PN 53412 for door-mounting details and measurements for A, B, and C size backboxes. This drawing shows EQBB-D4 knockout locations.

Figure 2.3 FACP Cabinet Mounting Details: Backbox-Mounting Holes and Chassis-Mounting Studs (EQBB-D4 shown)

2.2 Chassis-Mounting in FACP Cabinets

Up to four HPFF8CM units can fit into the FACP cabinet. Align the chassis with the backbox's mounting studs. Fasten securely with the hardware provided.

The Large Equipment Enclosure is made up of backbox EQBB-D4 with Notifier door EQDR-D4, or GW-FCI door FCI-VDR-D4B. Compatible Fire Alarm Control Panel cabinets include:

Number of units supported	CAB-4 series cabinets	EQ-series backbox/door
One	CAB-A4: SBB-A4 series backbox with DR-A4 series door assembly	EQBB-A4 with EQDR-A4 or FCI-VDR-A4B
Two	CAB-B4: SBB-B4 series backbox with DR-B4 series door assembly	EQBB-B4 with EQDR-B4 or FCI-VDR-B4B
Three	CAB-C4: SBB-C4 series backbox with DR-C4 series door assembly	EQBB-C4 with EQDR-C4 or FCI-VDR-C4B
Four	CAB-D4: SBB-D4 series backbox with DR-D4 series door assembly	EQBB-D4 with EQDR-D4 or FCI-VDR-D4B

Table 2.1 FACP Cabinets

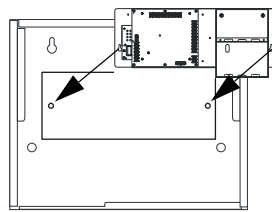

EQ4 and CAB-A4 Backboxes (one-row)

Note: Two-row and three-row mounting is equivalent. Drawings not to scale.

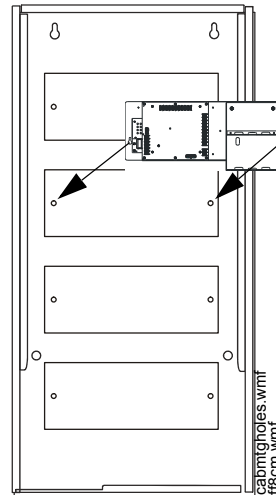

EQBB-D4 and CAB-D4 Backboxes (four-row)

Figure 2.4 Chassis-Mounting in FACP Cabinet (Overview)

See power-limited wiring Section 2.6.2, “Power-Limited Wiring, FACP Cabinet”, on page 26.

2.3 Chassis-mounting in CAB-4 and EQ Cabinets

2.3.1 CAB-4 Series Equipment Cabinets

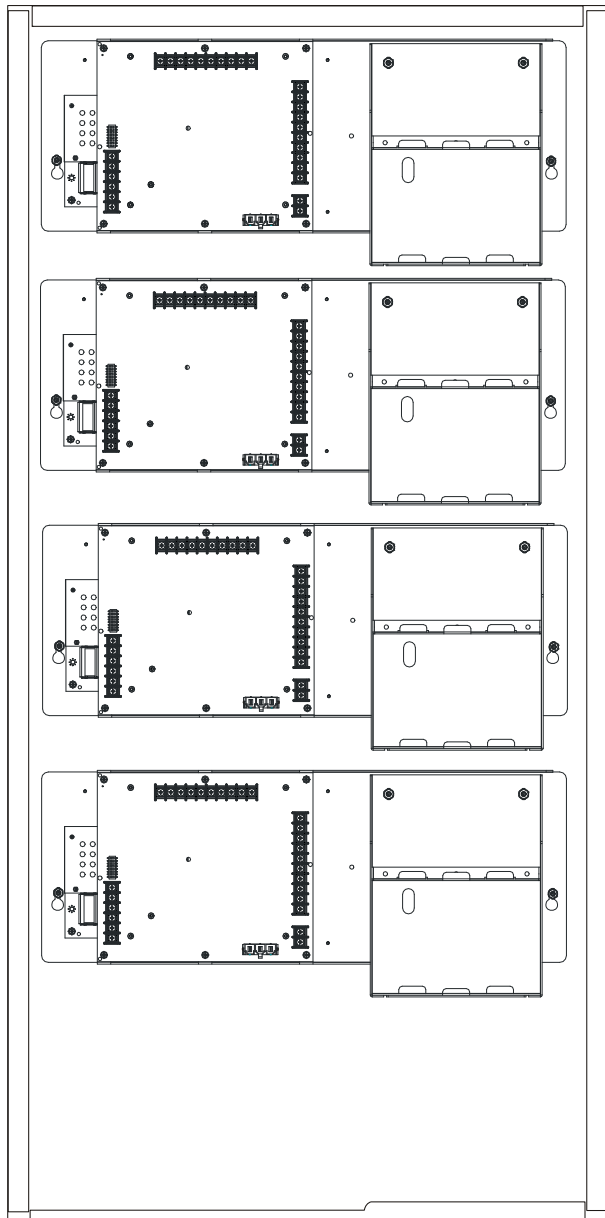

Figure 2.5 Four HPFF8CM Modules in a CAB-D4 Cabinet (SBB-D4 Backbox with DR-D4 Door)

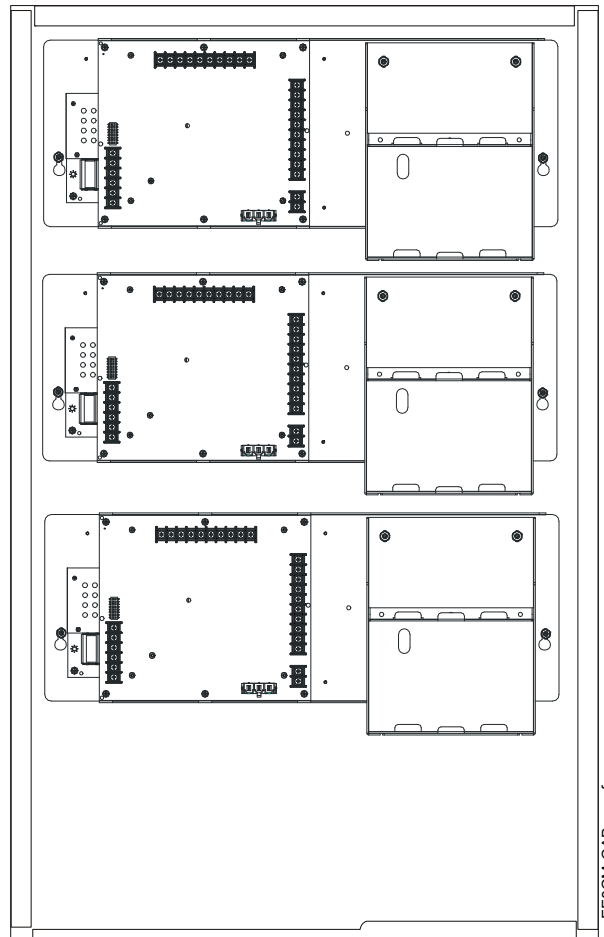

Figure 2.6 Three HPFF8CM Modules in a CAB-C4 Cabinet (SBB-C4 Backbox with DR-C4 Door)

2.3.2 EQ Series Equipment Cabinets

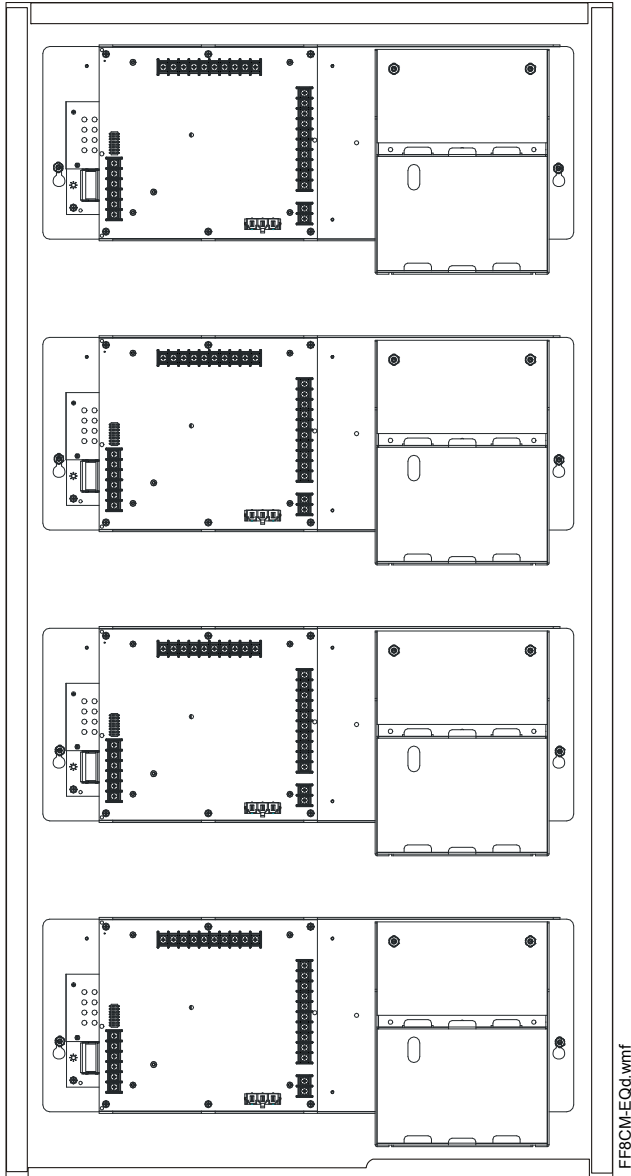

Figure 2.7 Four HPFF8CM Modules in an EQBB-D4 Cabinet (EQBB-D4 Backbox with EQDR-D4 Door)

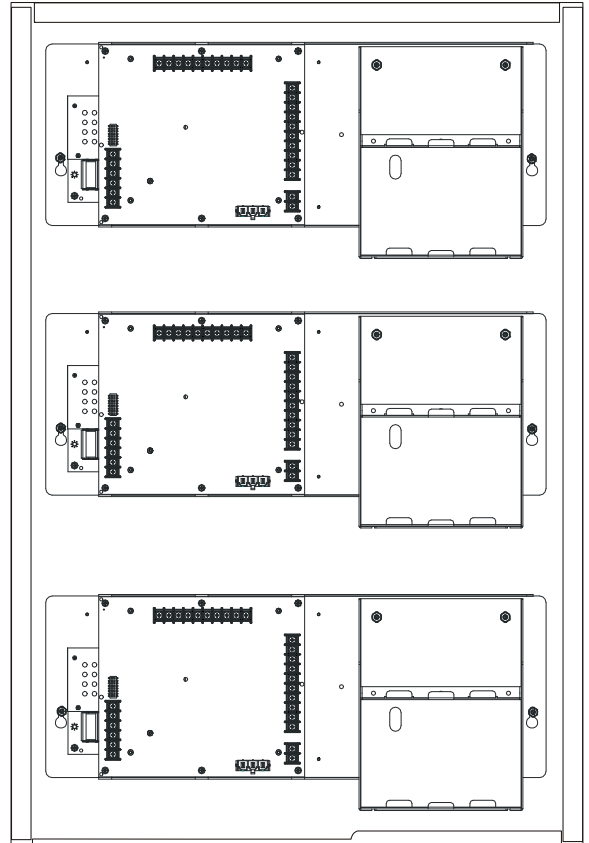

Figure 2.8 Three HPFF8CM Modules in an EQBB-C4 Cabinet (EQBB-C4 Backbox with EQDR-C4 Door)

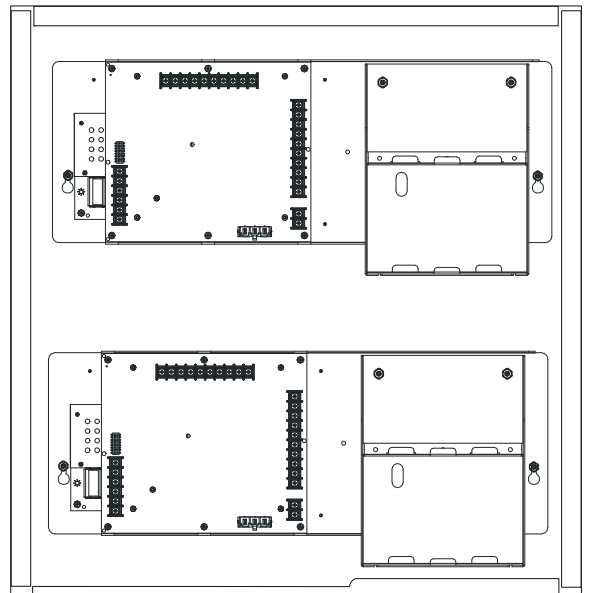

Figure 2.9 Two HPFF8CM Modules in an EQBB-B4 Cabinet (EQBB-B4 Backbox with EQDR-B4 Door)

2.4 NAC Circuit Wiring

For wiring sizes, see Section 6.5, “NAC Circuit Loop Wiring Requirements”.

2.4.1 Four NACs Configured for Class B (Style Y)

Figure 2.10 shows four NACs configured for Class B (Style Y).

- Trouble on NAC1 will illuminate LED1 SIG1 TRBL.
- Trouble on NAC2 will illuminate LED2 SIG2 TRBL.
- Trouble on NAC3 will illuminate LED3 SIG3 TRBL.
- Trouble on NAC4 will illuminate LED4 SIG4 TRBL.

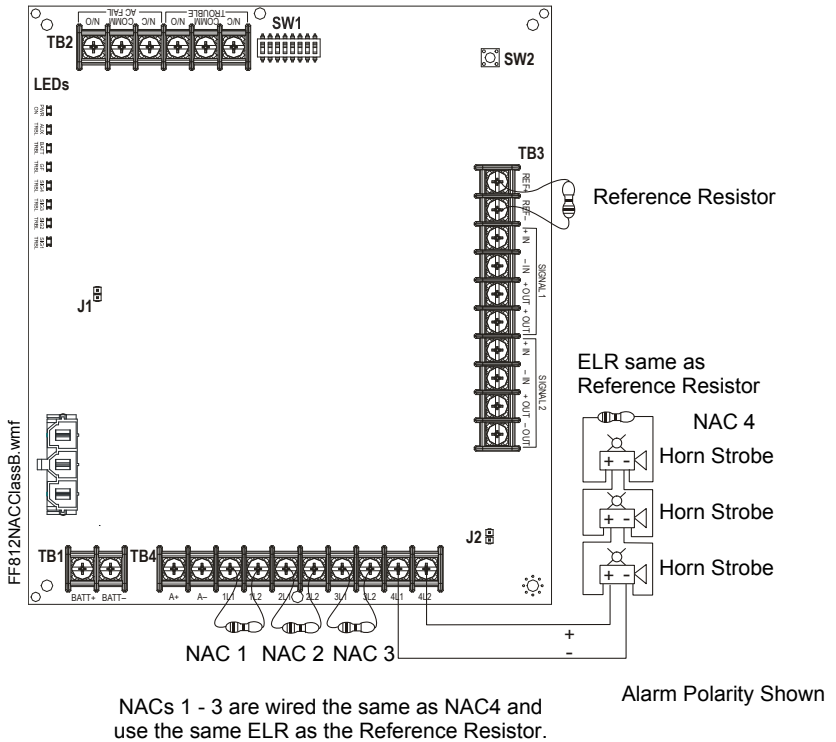

Figure 2.10 Four NACs in Class B (Style Y)



NOTES:

1. Typical ELRs for new installations can be 3.9k or 4.7k ohm.
2. The same gauge wire must be used if two conductors are connected to the same terminal of any terminal block.
3. Do not complete a continuous circuit around the screw terminal. There must be two separate wires on either side of the screw at the terminal block. “T-tapping” is absolutely NOT ALLOWED.

2.4.2 Two NACs Configured for Class A (Style Z)

Figure 2.11 shows two NACs configured for Class A (Style Z).

- Trouble on NAC1 will illuminate LED1 SIG1 TRBL and LED2 SIG2 TRBL
- Trouble on NAC2 will illuminate LED3 SIG3 TRBL and LED4 SIG4 TRBL

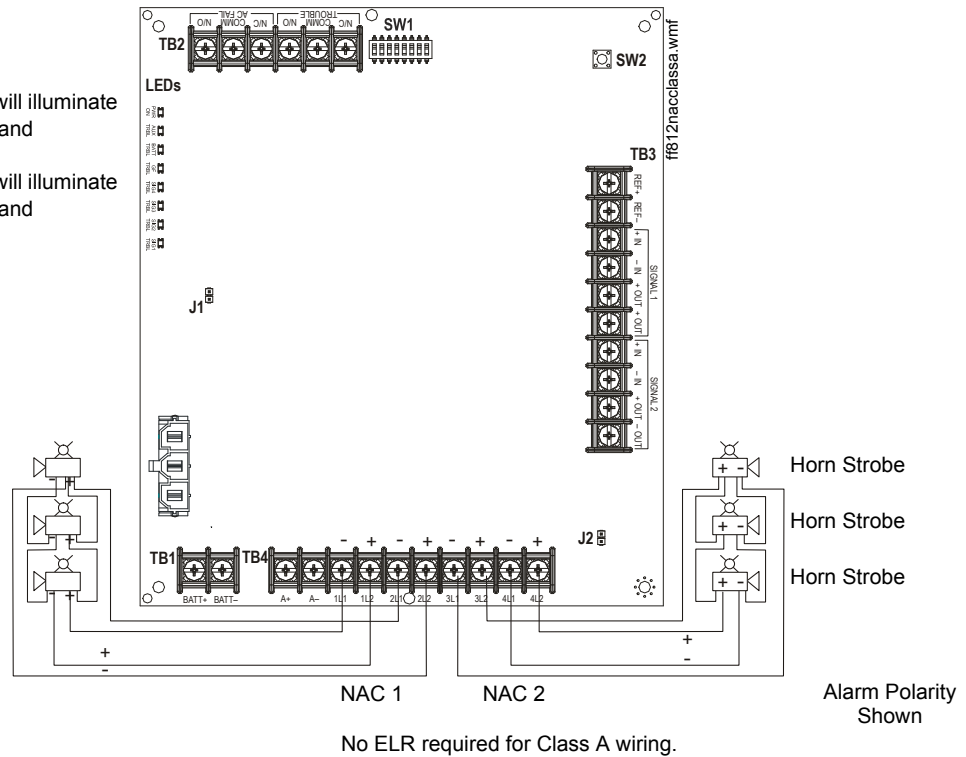

Figure 2.11 Two NACs in Class A (Style Z)



NOTES:

1. Typical ELRs for new installations can be 3.9k or 4.7k ohm.
2. The same gauge wire must be used if two conductors are connected to the same terminal of any terminal block.
3. Do not complete a continuous circuit around the screw terminal. There must be two separate wires on either side of the screw at the terminal block. "T-tapping" is absolutely NOT ALLOWED.

2.4.3 Mixing Class B and Class A NACs

Figure 2.12 shows two NACs configured for Class B (Style Y) and one NAC configured for Class A (Style Z).

- Trouble on NAC1 will illuminate LED1 SIG1 TRBL
- Trouble on NAC2 will illuminate LED2 SIG2 TRBL
- Trouble on NAC3 will illuminate LED3 SIG3 TRBL and LED4 SIG4 TRBL

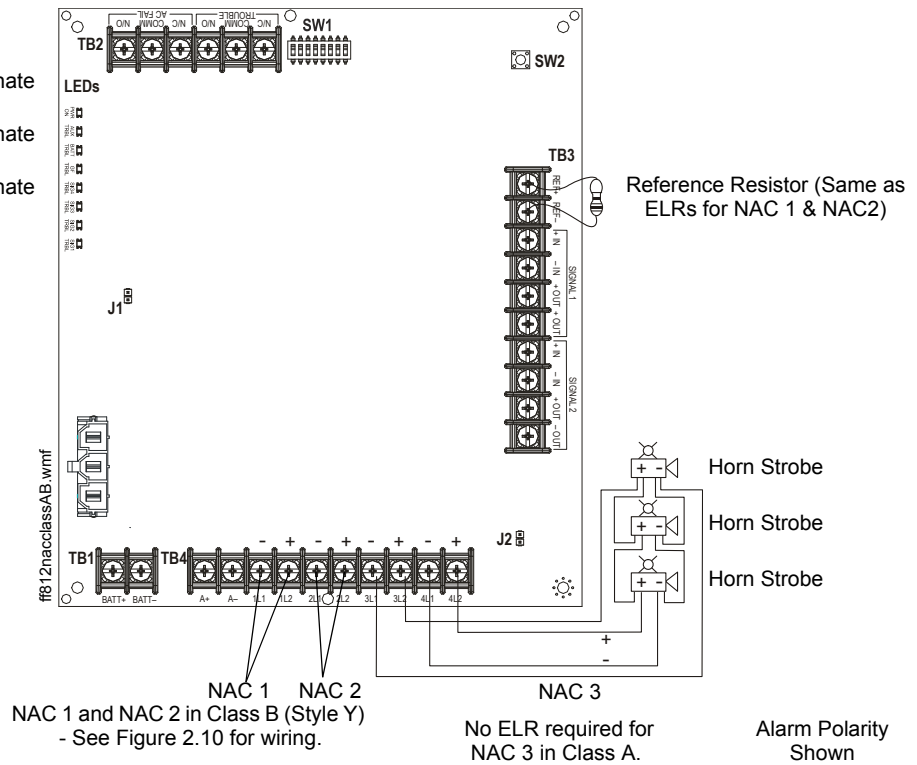

Figure 2.12 Configuring Two Class B NACs and One Class A NAC on One HPFF8



NOTES:

1. Typical ELRs for new installations can be 3.9k or 4.7k ohm.
2. The same gauge wire must be used if two conductors are connected to the same terminal of any terminal block.
3. Do not complete a continuous circuit around the screw terminal. There must be two separate wires on either side of the screw at the terminal block. "T-tapping" is absolutely NOT ALLOWED.

2.4.4 HPP31076 Optional Class A (Style Z) Adapter

The HPP31076 is an optional adapter to connect four Class A (Style Z) NAC circuits. It mounts directly onto the terminal block TB4 of the Control circuit board. The adapter kit includes two plastic standoffs to provide support. The same gauge wire must be used if two conductors are connected to the same terminal of any terminal block.



NOTE: Only use batteries with a maximum height of 4 inches in applications that require this adapter in the standard enclosure. Otherwise, there is insufficient space to connect NAC field wiring, and a separate NFPA and UL 864 rated enclosure is required.

- Trouble on NAC1 will illuminate LED1 SIG1 TRBL
- Trouble on NAC2 will illuminate LED2 SIG2 TRBL
- Trouble on NAC3 will illuminate LED3 SIG3 TRBL
- Trouble on NAC4 will illuminate LED4 SIG4 TRBL

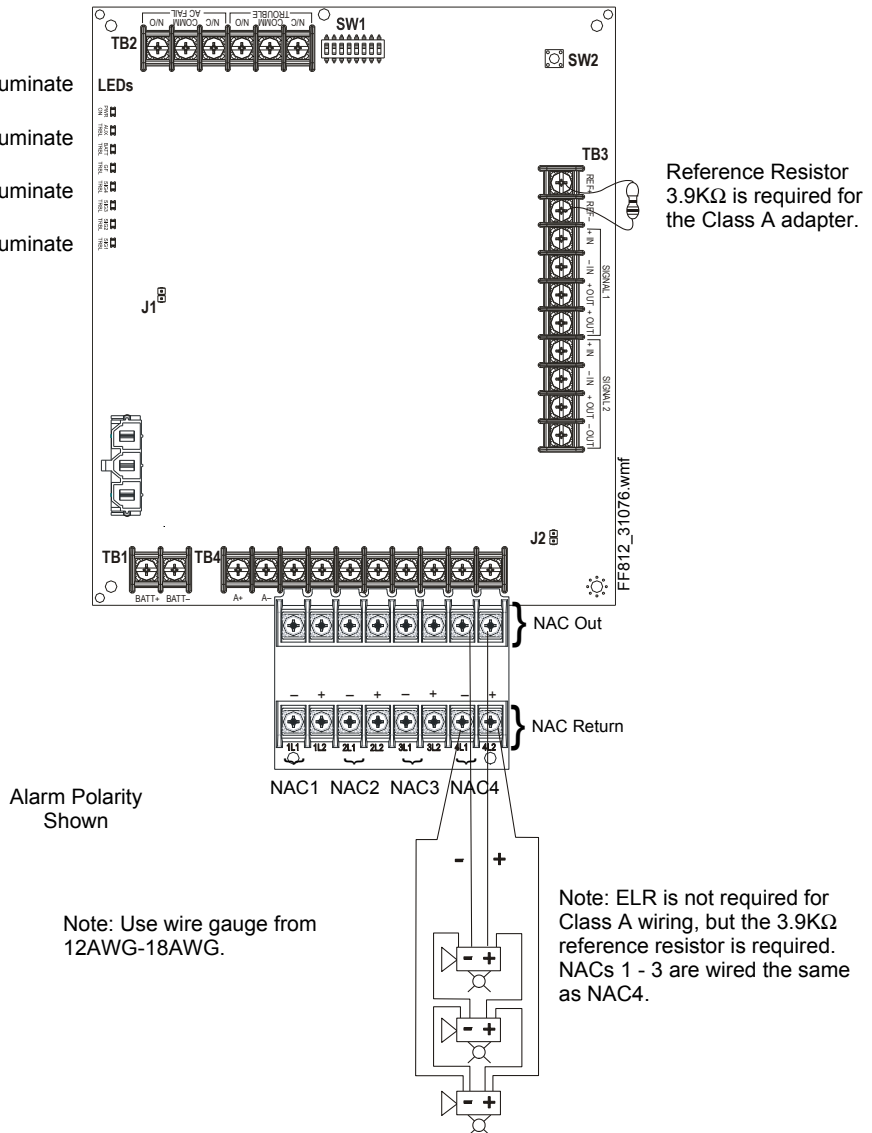

Figure 2.13 Four Class A (Style Z) NACs with HPP31076 Adapter



NOTES:

1. Typical ELRs for new installations can be 3.9k or 4.7k ohm.
2. The same gauge wire must be used if two conductors are connected to the same terminal of any terminal block.
3. Do not complete a continuous circuit around the screw terminal. There must be two separate wires on either side of the screw at the terminal block. "T-tapping" is absolutely NOT ALLOWED.

2.5 Mounting Addressable Modules

The HPFF8 and HPFF8E are designed to mount Honeywell Fire Systems addressable control or relay modules on the Control circuit board inside the power supply cabinet. This allows power to be fed from the Auxiliary output directly to the module, if needed, without running the power wires outside the cabinet. For a list of compatible optional modules that can be connected to the Auxiliary output, refer to the *HPP Device Compatibility Document*. Two single-output modules may be mounted directly above each other if required by applications such as Split Alarm or Selective Silence. Alternately, two outputs of a six-output addressable module can also be used and mounted on the Control board.



NOTE: An optional module mounting kit (P/N 90475) is required to install an addressable module on the Control circuit board. The kit includes four male/female standoffs as well four mounting screws. The standoffs install directly onto pems that are factory installed in the Control circuit board.

2.5.1 Mounting Modules from Honeywell Fire Systems

Addressable modules can be mounted directly to the Control circuit board as shown in Figure 2.14 for the wall cabinet. This allows wiring to remain in the cabinet. Two modules can be mounted on top of each other if the application requires two independent inputs, such as silencing. Alternately, two outputs of a six-output addressable module can also be used. The six-output module can also be mounted directly on the Control board.

Mounting addressable modules on the Control circuit board is also possible in the HPFF8CM and HPFF8CME units. However, the six-output module has to be mounted in an optional multi-module chassis if used in the large cabinet enclosure. See Section 2.6, “Power-Limited Wiring Requirements”.

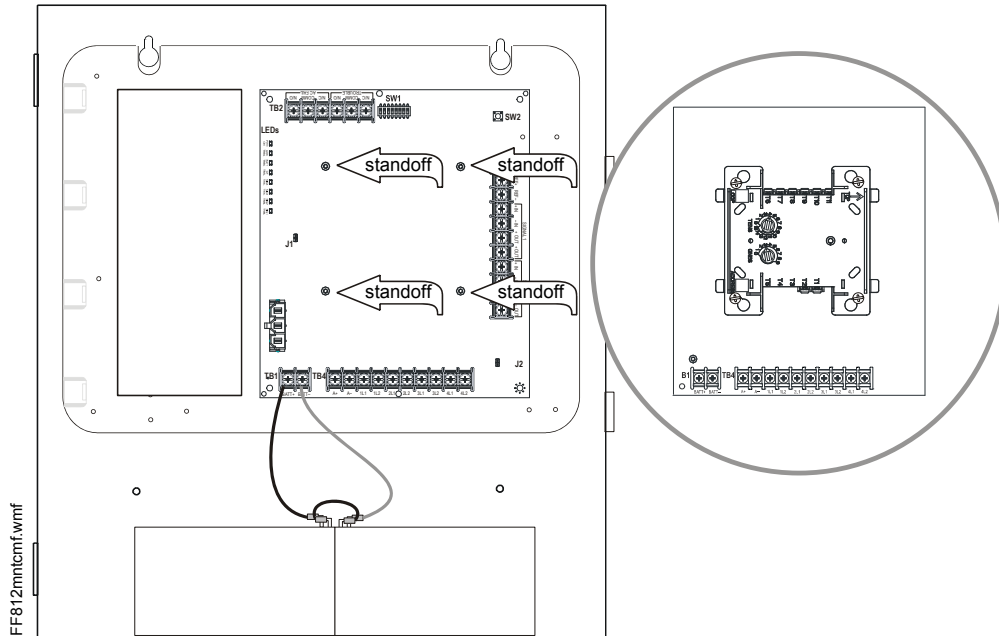

Figure 2.14 Mounting Details for Control & Relay Modules from Honeywell Fire Systems

2.5.2 Mounting Six-Circuit Modules from Honeywell Fire Systems

Six-output addressable modules can be mounted directly to the control circuit board as shown in Figure 2.15 for the wall cabinet. This allows wiring to remain in the cabinet. However, the six-output module cannot be mounted as shown in the HPFF8CM or HPFF8CME's units when used in the large equipment enclosure. An optional multi-module chassis is available from Honeywell Fire Systems. See Section 2.6, "Power-Limited Wiring Requirements".

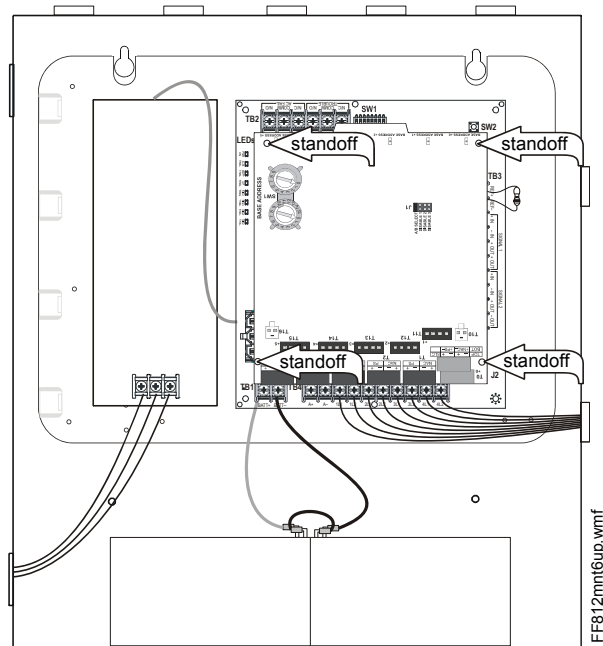

Figure 2.15 Mounting Details for Six-Output Modules from Honeywell Fire Systems

2.6 Power-Limited Wiring Requirements

Power-limited and nonpower-limited circuit wiring must remain separated in the cabinet. All power-limited wiring must remain at least 0.25" away from any nonpower-limited circuit wiring. Furthermore, all power-limited circuit wiring and nonpower-limited circuit wiring must enter and exit the cabinet through different conduits. An example of this is shown below. Your specific application may require different conduit knockouts to be used in the standard cabinet. Any conduit knockouts may be used. For power-limited applications, use of conduit is optional.

Connect the incoming earth ground wire to supplied cable #71073 with a wire nut. Position the ring terminal end over the grounding stud. Secure with one of the keps nuts. Place the ring terminal from the other supplied ground cable #71073 over the ground stud and secure with the second keps nut. Wire the ground cable to the middle position of TB1 on the 24VDC power supply circuit board. This connection is vital in reducing the panel's susceptibility to transients generated by lightning and electrostatic discharge. Apply AC power to the panel only after the system is completely installed and visually checked. *Note that AC power must be applied to the panel before installing the battery interconnect cable.*

2.6.1 Power-Limited Wiring, Standard Chassis

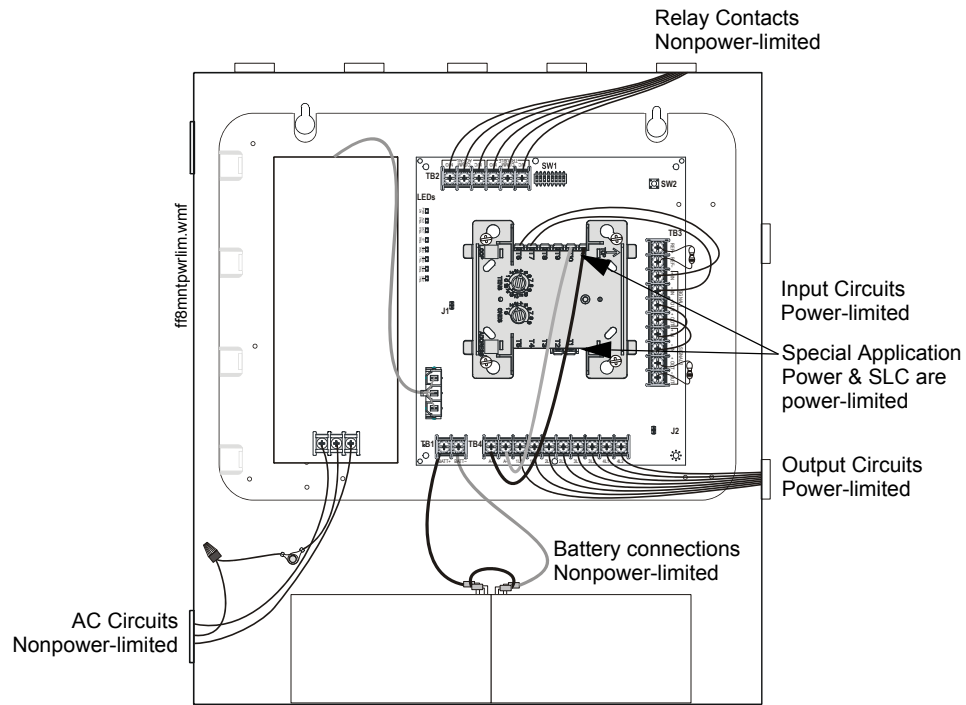

Figure 2.16 Power-Limited Wiring Example: Single-input Control Module

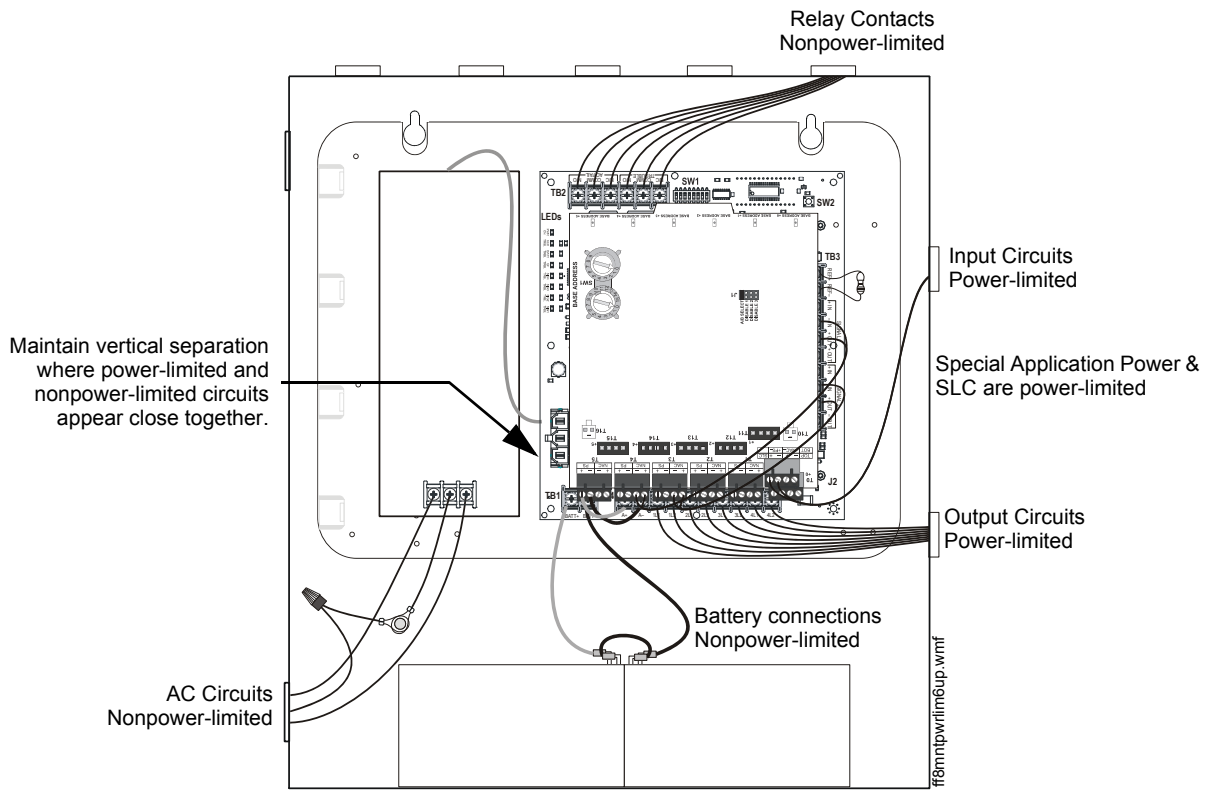

Figure 2.17 Power-Limited Wiring Example: Multi-Module

2.6.2 Power-Limited Wiring, FACP Cabinet

Figures 2.18 and 2.19 show the most complicated wiring example — a four-row cabinet. Cabinets with fewer rows follow the same wiring requirements.

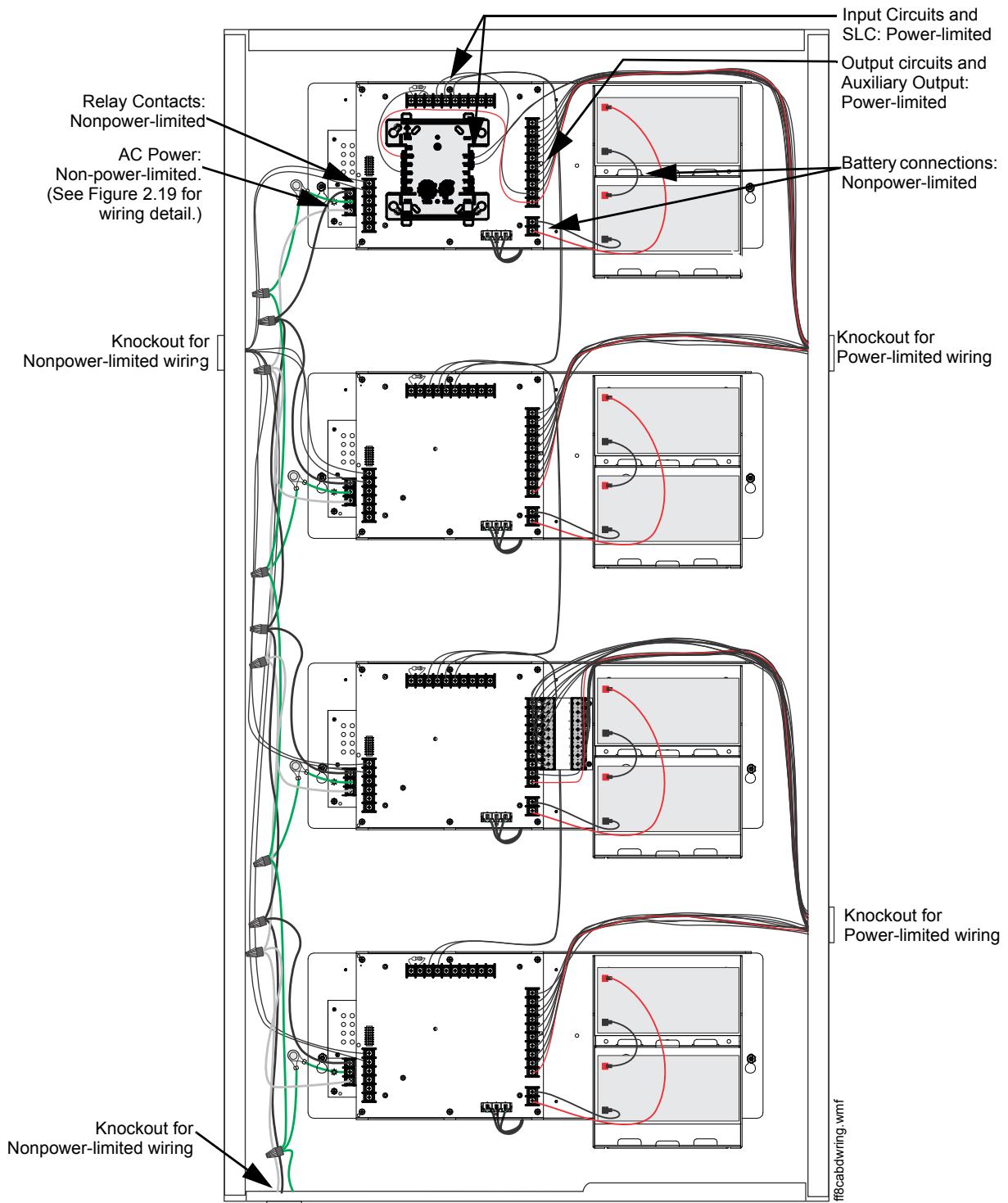

Figure 2.18 Power-Limited Wiring Example: EQBB-D4



NOTE: Maintain vertical separation where power-limited and nonpower-limited circuits appear to “cross” (e.g. Relay Contacts and AC Power).

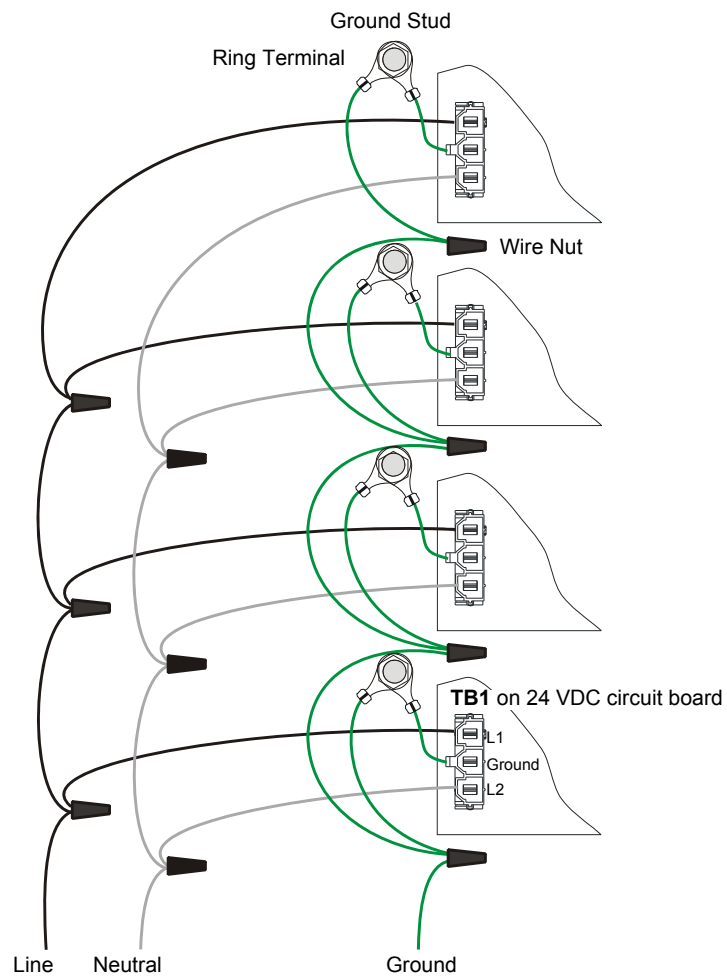

Figure 2.19 Nonpower-Limited Wiring Example: EQBB-D4 AC Wiring (Expanded)

Section 3: Programming Options

This section describes the programming options available via DIP switch settings. The HPFF can be field-programmed using DIP switch SW1 on the Control circuit board. Refer to the following illustration for switch location and DIP switch settings for ON and OFF positions.

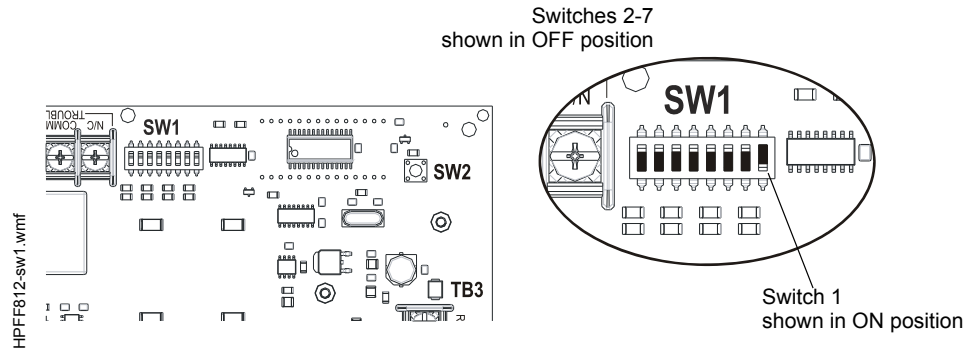

Figure 3.1 Field-Programming DIP Switches

3.1 DIP Switch Settings

The following table lists the programmable features and the switch settings required to select a particular feature. A detailed description of each is presented in the following pages.

	SW1 DIP Switch
1 SIG 1/2 "A" 2 SIG 1/2 "A"	1 OFF, 2 OFF = Pass-through (Slave) (of Steady On, sync, or coded; DO NOT use with full-wave rectified input). 1 ON, 2 OFF = Temporal. 1 OFF, 2 ON = Sync generator (see switches 5 & 6). 1 ON, 2 ON = Pass-through (Slave) Filtered (use for full-wave rectified inputs).
3 SIG 3/4 "B" 4 SIG 3/4 "B"	3 OFF, 4 OFF = Pass-through (Slave) (of Steady On, sync, or coded; DO NOT use with full-wave rectified input). 3 ON, 4 OFF = Temporal. 3 OFF, 4 ON = Sync generator (see switches 5 & 6). 3 ON, 4 ON = Pass-through (Slave) Filtered (use for full-wave rectified inputs).
5 SYN SEL "B" 6 SYN SEL "A"	5 OFF, 6 OFF = Cooper Wheelock 5 ON, 6 OFF = System Sensor 5 OFF, 6 ON = Amseco and Faraday 5 ON, 6 ON = Gentex
7 AC 2HR	OFF - No delay in Trouble reporting with an AC failure. ON - 2 hour delay in Trouble reporting with an AC failure. See Sections 3.2.3 and 3.2.4 for further details of TB2 immediate AC Fail and programmed no delay/delayed Trouble contacts.
8 SIG SEL	This switch works in conjunction with the initiating device signal input(s) and switches 1 through 6 to determine General Alarm*, Split Alarm**, or Silencing***. 8 ON = Split Alarm** • NAC outputs 1 and 2 are controlled by Signal Input 1. • NAC outputs 3 and 4 are controlled by Signal Input 2. 8 OFF, Signal Input 1 ON, Signal Input 2 ON = General Alarm* on all four NAC outputs. 8 OFF, Signal Input 1 ON, Signal Input 2 OFF = Silencing*** of all four NAC outputs. *General Alarm is visual strobe and audible horn activation. **Split Alarm is Signal Input 1 controlling NAC outputs 1 and 2, and Signal Input 2 controlling NAC outputs 3 and 4. ***Silencing is visual strobe activation but audible horn is silenced for the initiating device.

Table 3.1 DIP Switch Settings

3.2 Programmable Features

3.2.1 Input/Output Functions

DIP switches 1 through 4 are used to determine the input to output functions of the HPFF power supplies. The NAC outputs are programmed in pairs. DIP switches 1 and 2 are used to determine the input to output functions for NAC outputs 1 and 2. DIP switches 3 and 4 are used determine the input to output functions for NAC outputs 3 and 4.

NAC Outputs 1 & 2		
DIP Switch 1	DIP Switch 2	Function
OFF	OFF	Pass-through (Slave) (of Steady On, sync, or audible coded; DO NOT use with full-wave rectified input).
ON	OFF	Temporal generator.
OFF	ON	Sync generator (see Synchronization Type below).
ON	ON	Pass-through (Slave) Filtered (use for full-wave rectified inputs).

Table 3.2 Input/Output Configurations for NACs 1 & 2

NAC Outputs 3 & 4		
DIP Switch 3	DIP Switch 4	Function
OFF	OFF	Pass-through (Slave) (of Steady On, sync, or audible coded; DO NOT use with full-wave rectified input).
ON	OFF	Temporal generator.
OFF	ON	Sync generator (see Synchronization Type below).
ON	ON	Pass-through (Slave) Filtered (use for full-wave rectified inputs).

Table 3.3 Input/Output Configurations for NACs 3 & 4

The pass-through (Slave) feature passes any signal on the initiating device inputs to the NAC outputs. These signal inputs are independent in pass-through, so visual sync protocol and audible coded signals may be passed simultaneously. The signal types may include steady-on, march time, temporal or audible coded signals.

The temporal generator feature is used to have the power supply generate a temporal audible code.

The filtered feature is used to provide a steady-on output with full-wave rectified unfiltered input, and can be used to reduce or eliminate spurious outputs that are caused by noise on the inputs.

3.2.2 Synchronization Type

Synchronization is a feature that controls the activation of notification appliances in such a way that all devices turn on and off at exactly the same time. Unsynchronized strobe activation can be a potential hazard and can cause confusion. The HPFF power supplies can be programmed to operate with a variety of manufacturers' devices.

DIP switches 5 and 6 are used to select the synchronization type when switches 1 & 2 and 3 & 4 are programmed for the power supply to be a sync generator.

DIP Switch 5	DIP Switch 6	Synchronization Type
OFF	OFF	Cooper Wheelock devices
ON	OFF	System Sensor devices
OFF	ON	Amseco and Faraday devices
ON	ON	Gentex devices

Table 3.4 Synchronization Type for DIP Switches 5 and 6

3.2.3 Trouble Reporting Delay with an AC Failure

There are three ways to report trouble of AC loss or brownout. The transfer of TB2's AC FAIL contacts, TB2's TROUBLE contacts, and the opening of the FACP or initiating device SIGNAL 1's and SIGNAL 2's connections on TB3.

Both SIGNAL 1's and SIGNAL 2's +IN to +OUT connections are opened to disconnect Class B ELRs or the positive wire run of Class A configuration. They remain closed in the alarm state, even if a trouble condition exists, to pass the alarm signal if multiple units are connected. Therefore, supervised monitoring TB2's AC FAIL and TROUBLE contacts is necessary for UL 864 9th Edition compliance.

- DIP switch 7 set to the ON position will delay the transfer of the TB2's TROUBLE contacts and the opening of connections on TB3 for 2 hours (unless in alarm state), upon an AC loss or brownout.
- DIP switch 7 set to the OFF position will have no delay in the transfer of the TB2's TROUBLE contacts and the opening of ELR connections on TB3 (unless in alarm state), upon an AC loss or brownout.

TB2's AC FAIL contacts will always immediately transfer if an AC loss or brownout occurs, regardless of DIP switch 7 setting. These contacts can be used for local reporting to the protected premises, in compliance with UL 864 9th Edition.

The DIP switch 7 setting of a 2 hour delay of TB2 TROUBLE contacts can be used for remote station, central station, or proprietary protected premises reporting, in compliance with UL 864 9th Edition.



NOTE: For UL 864 9th Edition compliance, always use supervised monitoring of TB2's AC FAIL and TROUBLE contacts and set DIP switch 7 for a delay.

3.2.4 Split Alarm and Silencing

DIP switch 8, in conjunction with initiating device signal inputs and DIP switches 1 through 6, is used to program the features of General Alarm, Split Alarm, or Silencing.

- DIP switch 8 set to the ON position will split the NAC outputs to pairs. NAC outputs 1 & 2 are controlled by Signal Input 1 and NAC outputs 3 & 4 are controlled by Signal Input 2. The output pairs will be selectively silenced if DIP switches 1 through 6 are set for Pass-through (Slave) and FACP input is wired and programmed for that operation.
- DIP switch 8 set to the OFF position and at least one of the NAC outputs are programmed for synchronization, Signal Input 1 & 2 ON will generate a General Alarm on all four NAC outputs. General Alarm is activation of both visual strobe and audible horns.
- DIP switch 8 set to the OFF position and at least one of the NAC outputs are programmed for synchronization, Signal Input 1 ON and Signal Input 1 OFF will silence all four NAC outputs while keeping visual strobe activation.



NOTE: See Sections 5.1 and 5.2 for proper alarm input wiring when DIP switch 8 is programmed in the OFF position.

Section 4: Trouble Supervision

4.1 Supervised Functions and Field Wiring

- Field-wiring fault (short or open) on the NAC outputs of the power supply
- AC failure or brownout at the power supply
- Battery failure (no battery or battery voltage less than 20.5 VDC) condition at the power supply
- Battery charger failure on the power supply
- Ground fault condition
- +/- Reference Resistor



NOTE: The trouble contacts AC FAIL and TROUBLE on TB2 and initiating device inputs SIGNAL1 and SIGNAL2 on TB3 are not supervised by the HPFF8, but are used for supervision of the HPFF8 by the FACP.

4.2 Trouble Reporting

4.2.1 Normal/Standby

Normal / Standby			Trouble contacts			LED		Reset?
Fault			TB2: AC FAIL	TB2: TROUBLE	TB3: +IN & +OUT			
Field Wiring (NAC & +/-REF)	Short or Open	Present	(Note ¹)	(Note ²)	open	LED1: SIG1 TRBL	Steady illumination	Auto
						LED2: SIG2 TRBL	Steady illumination	Auto
						LED3: SIG3 TRBL	Steady illumination	Auto
						LED4: SIG4 TRBL	Steady illumination	Auto
	Past (Trouble Memory)	(Note ¹)	(Note ¹)	closed	LED1: SIG1 TRBL	Blink	SW1 or Power cycle	
					LED2: SIG2 TRBL	Blink	SW1 or Power cycle	
					LED3: SIG3 TRBL	Blink	SW1 or Power cycle	
					LED4: SIG4 TRBL	Blink	SW1 or Power cycle	
Ground Fault			(Note ¹)	(Note ¹)	open	LED5: GF TRBL	Steady illumination	Auto
Battery	No Battery or <20.5 VDC		(Note ¹)	(Note ²)	open	LED6: BATT TRBL	Steady illumination	Auto
Battery Charger	Fault		(Note ¹)	(Note ²)	open	LED6: BATT TRBL	Blink	Auto
	Battery not reach float (Note ³)		(Note ¹)	(Note ²)	open	LED6: BATT TRBL	Steady illumination	Auto
Auxiliary output	Excessive load or short		(Note ¹)	(Note ²)	open	LED7: AUX TRBL	Steady illumination	Auto
AC	Loss or Brownout	No Delay	immediate transfer	no delay transfer	no delay open	LED8: PWR ON	Blink	Auto
		Delay	immediate transfer	2hr delayed transfer	2hr delayed open	LED8: PWR ON t	Blink	Auto

1. No transfer and COMM & N/C are shorted.
2. The shorted contacts of COMM & N/C transfer to COM & N/O.
3. A battery fail indication can also occur if there was an AC failure within the first 24 hours after initial power-up and the battery voltage had been discharged to a voltage between 20.5- 26.5 VDC. The BATT TRBL battery trouble LED may illuminate steady, after a certain delay during charging, to indicate the battery was discharged and may not support a full alarm load. The delay is based on operational conditions (time remaining in the first 24 hours, time in stand-by, and time in alarm) and will extinguish if the battery charging has time to reach its float voltage.

4.2.2 Alarm

Alarm			Trouble contacts					
Fault			TB2: AC Fail	TB2: TROUBLE	TB3: +IN & +OUT	LED		Reset?
Field Wiring (NAC & +/- REF)	Short or Open	Excessive Load (Two re-tries of >4 Amps)	(Note 1)	(Note 2)	closed	LED1: SIG1 TRBL	Steady Illumination	SW1 or Power cycle
						LED2: SIG2 TRBL	Steady Illumination	SW1 or Power cycle
						LED3: SIG3 TRBL	Steady Illumination	SW1 or Power cycle
						LED4: SIG4 TRBL	Steady Illumination	SW1 or Power cycle
Ground Fault		(Note 1)	(Note 2)	closed	LED5: GF TRBL	Steady Illumination	Auto	
Battery	No battery or <20.5 VDC		(Note 1)	(Note 1)	closed	LED6: BATT TRBL	(Note 4)	(Note 4)
Battery Charger	Fault		(Note 1)	(Note 1)	closed	LED6: BATT TRBL	(Note 4)	(Note 4)
	Battery not reach float (Note 3)		(Note 1)	(Note 1)	closed	LED6: BATT TRBL	(Note 4)	(Note 4)
Auxiliary Output	Excessive load or short		(Note 1)	(Note 1)	closed	LED7: AUX TRBL	Steady Illumination	Auto
AC	Loss or Brownout	No Delay	Immediate transfer	No delay transfer	closed	LED8: PWR ON	Blink	Auto
		Delay	Immediate transfer	2hr delayed transfer	closed	LED8: PWR ON	Blink	Auto

1. No transfer and COMM & N/C are shorted.
2. The shorted contacts of COMM & N/C transfer to COM & N/O.
3. A battery fail indication can also occur if there was an AC failure within the first 24 hours after initial power-up and the battery voltage had been discharged to a voltage between 20.5- 26.5 VDC. The BATT TRBL battery trouble LED may illuminate steady, after a certain delay during charging, to indicate the battery was discharged and may not support a full alarm load. The delay is based on operational conditions (time remaining in the first 24 hours, time in stand-by, and time in alarm) and will extinguish if the battery charging has time to reach its float voltage.
4. Battery Charger disabled during alarm.

4.2.3 TB2: AC FAIL Contacts

TB2's AC FAIL contacts are not supervised by the HPFF power supply, but will be supervised by the FACP. The normally shorted COMM and N/C contacts will transfer to the COMM and N/O contacts being shorted, only when an AC failure occurs. The transfer always occurs immediately and will not be delayed even if DIP switch 7 is in the ON position. These contacts should be used for local reporting of an AC failure for compliance of UL 864 9th Edition.

4.2.4 TB2: TROUBLE Contacts

TB2's TROUBLE contacts are not supervised by the HPFF power supply, but will be supervised by the FACP. The normally shorted COMM and N/C contacts will transfer to the COMM and N/O contacts being shorted when a fault condition occurs. The transfer will not be delayed except if the fault is an AC failure and DIP switch 7 is in the ON position. The transfer will be delayed for 2 hours in this case. These contacts should be used for delayed remote reporting of an AC failure for compliance of UL 864 9th Edition.

4.2.5 TB3: Initiating Device Inputs SIGNAL 1 and SIGNAL 2

TB3's alarm SIGNAL 1 and SIGNAL 2 inputs are not supervised by the HPFF power supply. They will be supervised by the FACP or initiating device. The four connections +IN, -IN, +OUT, and -OUT are used to connect either from a two-wire/Class B (Style Y) NAC with an end-of-line resistor (ELR) or a four-wire/Class A (Style Z) NAC.

Both SIGNAL 1's and SIGNAL 2's +IN to +OUT connections are opened to disconnect Class B ELRs or the positive connection of Class A input. However, they will always remain closed* in the alarm state, even if a trouble condition exists. The alarm signal will then be passed if multiple units are connected.



NOTE: *TB3's SIGNAL 1 and SIGNAL 2 connections remain closed in the alarm state. Always use supervised monitoring of TB2's TROUBLE and AC FAIL contacts to annunciate troubles at the FACP.

4.2.6 Trouble Memory

The HPFF has NAC Trouble Memory by storing the NAC output number(s) when a trouble has been experienced. The unit will then blink the corresponding yellow SIG TRBL LED(s) when all the troubles are cleared. This helps the installer or repair personnel to find the cause of intermittent troubles.

The NAC Trouble Memory is permanently latched. To clear it, the AC must be cycled and the battery momentarily disconnected, or just press SW2 (microprocessor reset) on the control PCB.

If the panel is in alarm, an excessively loaded or shorted NAC is the only trouble condition that will cause the Trouble contacts to transfer.

If the current in any NAC exceeds 3.5 A due to excessive loading, the unit disables its output for approximately 8 seconds. The unit will then attempt to re-engage the NAC output(s), and will disable it if the 3.5 A is exceeded again. If an overload condition exceeding 4.0 A exists for more than two re-engagements, the unit will illuminate the corresponding yellow SIG TRBL LED(s) steady and generate a general trouble. This is a latched overload condition, but the unit will keep attempting to re-engage the NAC output. The general trouble transfers only the Trouble contact until the alarm condition clears.

4.2.7 Ground Fault Detection

A ground fault trouble will be generated if there is 76 K ohms or lower between Earth Ground and the field wiring, except the initiating device SIGNAL 1 and SIGNAL2 inputs and TB2 AC FAIL and TROUBLE contacts. The signal inputs are optically-isolated from the HPFF's circuitry and will be supervised by the FACP. TB2's contacts are dry contacts and will be supervised by the FACP.

4.2.8 NAC Overload Protection and Indication

If the current in any NAC exceeds 3.5 A due to excessive loading, the unit disables its output for approximately 8 seconds. The unit will then attempt to re-engage the NAC output(s), and will disable it if the 3.5 A is exceeded again. If an overload condition exceeding 4.0 A exists for more than two re-engagements, the unit will illuminate the corresponding yellow SIG TRBL LED(s) steady and transfer the TB2's TROUBLE contacts. This is a latched overload condition, but the unit will keep attempting to re-engage the NAC output while in alarm.

To clear the permanently latched overload condition, the AC must be cycled and the battery momentarily disconnected, or just press SW2 (microprocessor reset) on the Control circuit board.

Notes

Section 5: Applications

5.1 Controlling Four NAC Circuits from a Single Source

In this application, all four NACs (Notification Appliance Circuits) are controlled by a single input from a FACP (Fire Alarm Control Panel) as illustrated in Figure 5.1. The FACP could be replaced by a supervised addressable control module associated with a fire alarm control panel.

If the Programming DIP Switches are set as shown below, all four NACs will follow (Pass-through/Slave) the signal from the FACP.

SW1-8	SW1-7	SW1-6	SW1-5	SW1-4	SW1-3	SW1-2	SW1-1
OFF	N/A	OFF	OFF	OFF	OFF	OFF	OFF

All four NAC outputs will follow FACP output. FACP output can be steady on, coded, temporal, sync, etc.

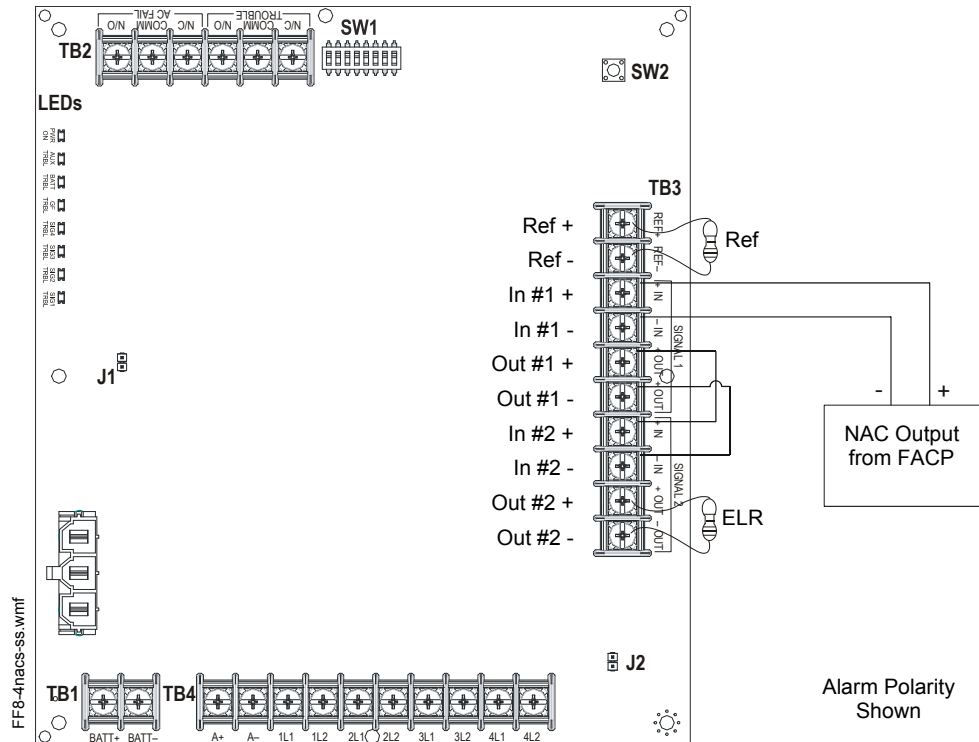

Figure 5.1 Controlling Four NAC Circuits from a Single Source

Notes for Figure 5.1:

1. When the power supply is in normal/standby state, a trouble will result in an open circuit condition on the FACP's NAC circuit (monitored by End-of-Line Resistor across TB3). The HPPF's alarm input circuit will always remain closed in the alarm state. Therefore, the Trouble contacts at TB2 need to be used to report troubles to the FACP during an alarm. See Section 4.1, "Supervised Functions and Field Wiring".
2. The FACP's NAC circuit can be steady on, coded, temporal, Sync, etc.
3. The value of the ELR (End-of-Line Resistor) across TB3 terminals SIGNAL 2 +OUT & -OUT depends on the FACP used.
4. For a list of compatible devices, refer to the *HPP Device Compatibility Document*.
5. The same gauge wire must be used if two conductors are connected to the same terminal of any terminal block.
6. Do not complete a continuous circuit around the screw terminal. There must be two separate wires on either side of the screw at the terminal block. "T-tapping" is absolutely NOT ALLOWED.

5.2 Controlling and Silencing Four NACs

In this application, the power supply has been set as a master with synchronized, silenceable outputs (see SW1 switch settings in following illustration). The four NAC (Notification Appliance Circuits) output circuits can be silenced in the sync generation mode by removing alarm input from Signal Input 2. This can be accomplished using two addressable modules as illustrated in Figure 5.2.

The FACP must be capable of a visual annunciation to the silencing status of the output or zone(s) to which the HPFF unit(s) are connected. The addressable modules are shown to demonstrate the use of a remotely mounted device associated with an addressable fire alarm control panel. The module could be replaced with any circuit capable of polarity reversal, such as an FACP NAC.

Two independent inputs are required for silencing. Two separate addressable modules can be used as shown in Figure 5.2, mounted on the control board (one on the other) or in a separate UL-Listed panel. Alternately, two outputs of a six-output addressable module can also be used and mounted on the Control board (see Section 5.3, “Split Alarm and Selective Silence”).

SW1-8	SW1-7	SW1-6	SW1-5	SW1-4	SW1-3	SW1-2	SW1-1
OFF	NA	OFF	ON	ON	OFF	ON	OFF

All four NAC outputs will have silenceable sync for System Sensor devices.

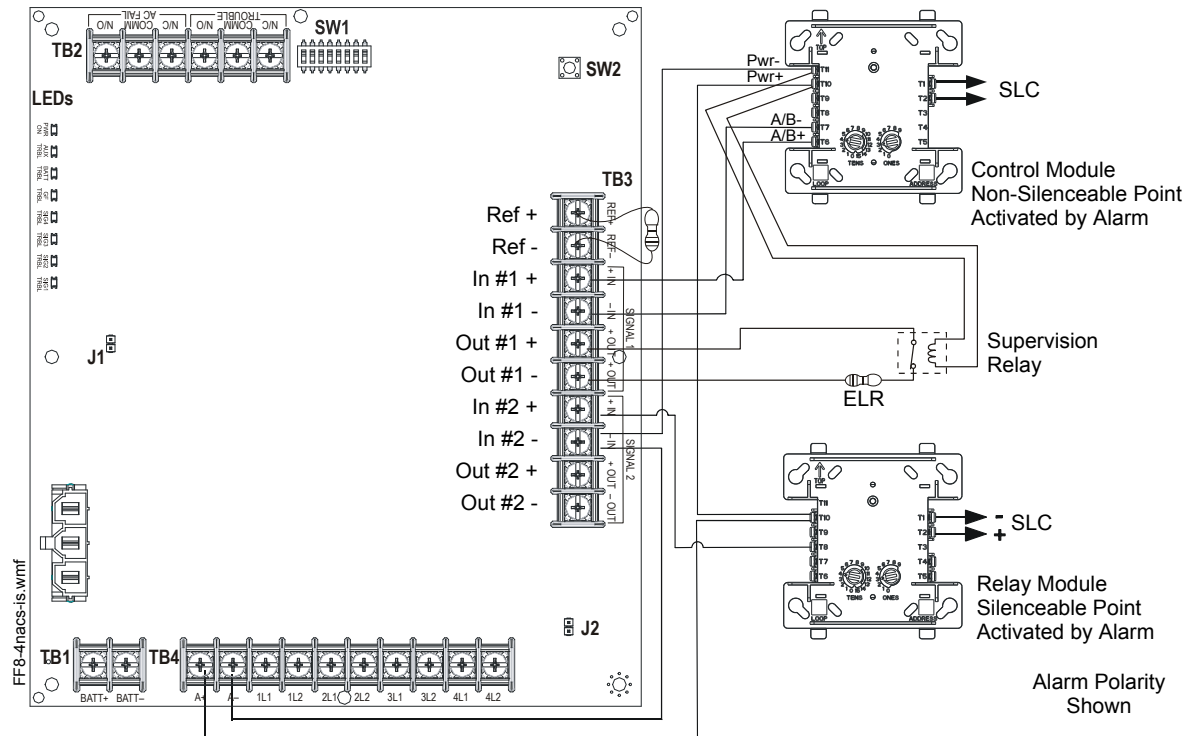

Figure 5.2 Controlling and Silencing Four NACs

Notes for Figure 5.2:

1. When the power supply is in normal/standby state, a trouble will result in an open circuit condition on the control module output circuit (monitored by the End-of-Line Resistor on TB3). The HPFF's alarm input circuit will always remain closed in the alarm state. Therefore, the Trouble contacts at TB2 need to be used to report troubles to the FACP during an alarm. Refer to Section 4.1 on page 31.
2. The addressable relay module must be programmed as a silenceable point at the FACP to allow silencing of horn/strobe devices.
3. The addressable control module must be programmed as a non-silenceable point at the FACP.
4. Do not loop wires under screw terminals. Break wires to maintain proper supervision.
5. The value of the ELR (End-of-Line Resistor) across TB3 terminals depends on the control module used.
6. For a list of compatible devices, refer to the *HPP Device Compatibility Document*.
7. The same gauge wire must be used if two conductors are connected to the same terminal of any terminal block.
8. Do not complete a continuous circuit around the screw terminal. There must be two separate wires on either side of the screw at the terminal block. “T-tapping” is absolutely NOT ALLOWED.

5.3 Split Alarm and Selective Silence

Selective silence can only be accomplished if the sync protocol from the FACP is passed through the HPFF8, which is configured for Split Alarm. The selective silencing is accomplished in pairs of NACs 1&2 and 3&4.

5.3.1 Selective Silence

In this application, the power supply and FACP have been configured for selective silence as illustrated in Figure 5.3. The sync protocol has to be passed through the HPFF8 from the FACP to selectively silence the NACs. The FACP must be capable of a visual annunciation to the silencing status of the output or zone(s) to which the HPFF unit(s) are connected.

If the Programming DIP Switches are set as shown below, all four NACs will follow (Pass-through/Slave) the signal from the FACP including which NAC output pair will be silenced.

SW1-8 ON	SW1-7 NA	SW1-6 OFF	SW1-5 OFF	SW1-4 OFF	SW1-3 OFF	SW1-2 OFF	SW1-1 ON
NAC 1 & 2 will NOT be silenced; NAC 3 & 4 will be silenced.							

Two independent inputs are required for silencing. Two separate addressable modules can be used as shown in Figure 5.2, mounted on the control board (one on the other) or in a separate UL-Listed panel. Alternately, two outputs of a six-output addressable module can also be used and mounted on the Control board as shown in Figure 5.4.

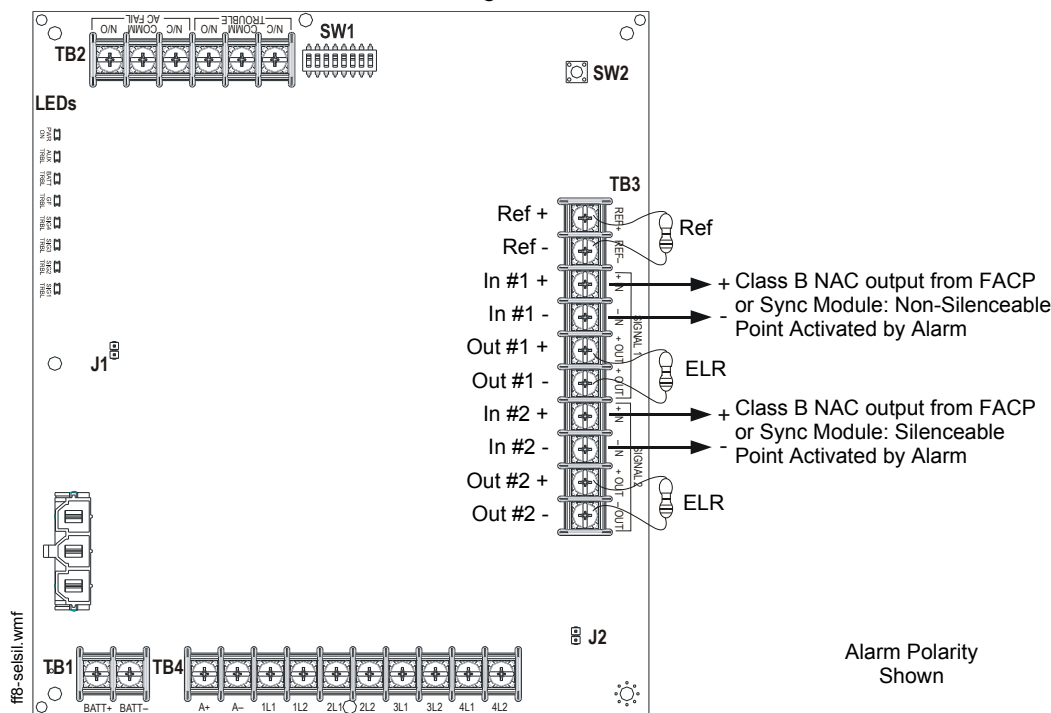

Figure 5.3 Wiring for Selective Silence

Notes for Figure 5.3:

1. When the power supply is in normal/standby state, a trouble will result in an open circuit condition on the control module output circuit (monitored by the End-of-Line Resistors on TB3). The HPFF’s alarm circuit will always remain closed in the alarm state. Therefore, the Trouble contacts at TB2 need to be used to report troubles to the FACP during an alarm. See Section 4.1, “Supervised Functions and Field Wiring”.
2. The FACP NAC outputs must be programmed as a silenceable points and the HPFF8 programmed for Selective/Split Alarm to allow selective silence of horn/strobe devices.
3. The value of the ELRs (End-of-Line Resistors) on TB3 depends on the FACP used.
4. For a list of compatible devices, refer to the *HPP Device Compatibility Document*.
5. The same gauge wire must be used if two conductors are connected to the same terminal of any terminal block.
6. Do not complete a continuous circuit around the screw terminal. There must be two separate wires on either side of the screw at the terminal block. “T-tapping” is absolutely NOT ALLOWED.

5.3.2 Split Alarm Mode

The Split Alarm mode shows the versatility of the HPFF8. A combination of coded signals can be generated by or passed-through to the NAC output circuit pairs of 1&2 and 3&4.

In this application, the power supply has been configured for Split Alarm mode. Control Input #1 (TB3, Terminals 3 & 4) is connected to an addressable control module which will control power supply output circuits 1 & 2. Control Input #2 (TB3, Terminals 7 & 8) is connected to an addressable relay module which controls output circuits 3 & 4.

If the programming DIP switches are set as shown below the power supply is set as a Sync Generator with two synchronized (System Sensor protocol) and two non-synchronized outputs. Control module #1 will cause the synchronized power supply output circuits 1 & 2 to turn on. Control module #2 will activate a Temporal Signal on output circuits 3 & 4.

SW8 ON	SW7 N/A	SW6 OFF	SW5 ON	SW4 OFF	SW3 ON	SW2 ON	SW1 OFF
NAC outputs circuits 1 & 2 will have sync for System Sensor device. NAC outputs circuits 3 & 4 will have a Temporal signal.							

Two independent inputs are required for Split Alarm. Two separate addressable modules can be used as shown in Figure 5.2, mounted on the control board (one on the other) or in a separate UL-Listed panel. Alternately, two outputs of a six-output addressable module can also be used and mounted on the control board shown in Figure 5.4.

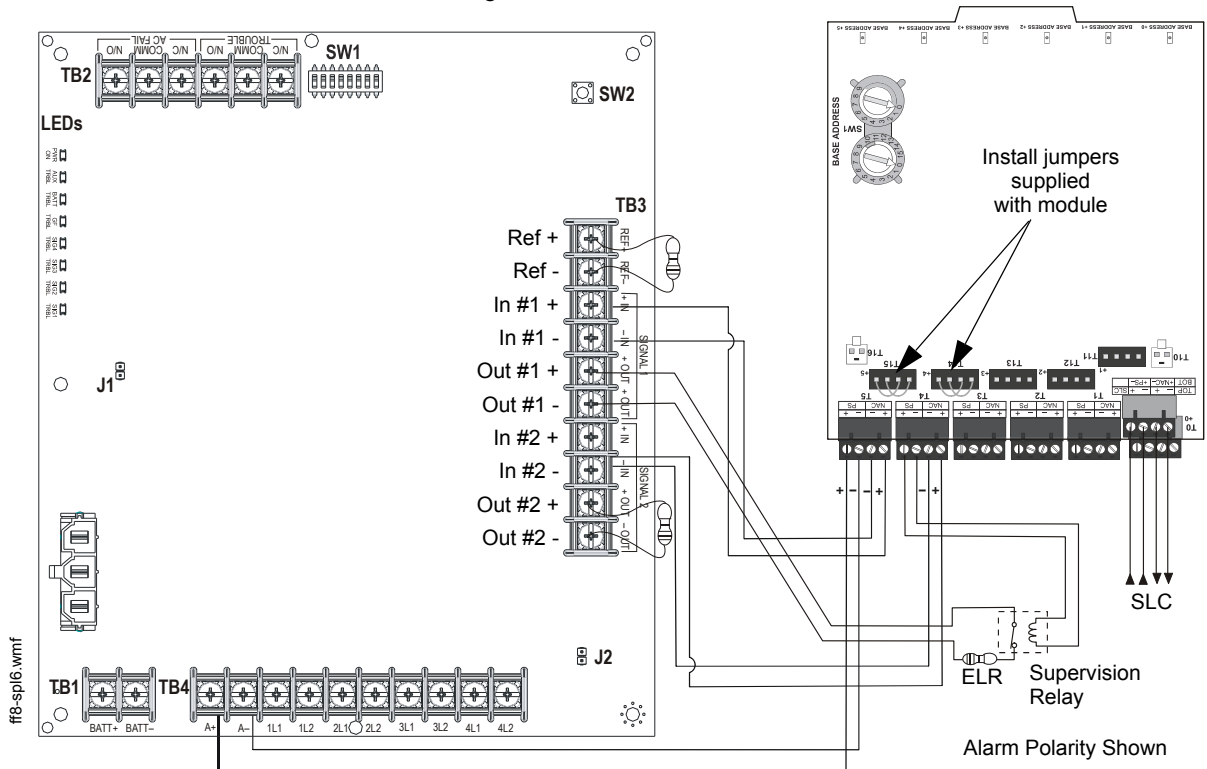

Figure 5.4 Wiring for Split Alarm Mode

Notes for Figure 5.4:

1. When the power supply is in normal/standby state, a trouble will result in an open circuit condition on the control module output circuit (monitored by the End-of-Line Resistors on TB3). The HPFF's alarm circuit will always remain closed in the alarm state. Therefore, the Trouble contacts at TB2 need to be used to report troubles to the FACP during an alarm. Refer to Section 4.1 on page 31.
2. Do not loop wires under screw terminals. Break wires to maintain proper supervision.
3. The value of the ELRs (End-of-Line Resistors) across TB3 terminals depends on the control module used.
4. For a list of compatible devices, refer to the *HPP Device Compatibility Document*.
5. The same gauge wire must be used if two conductors are connected to the same terminal of any terminal block.
6. Do not complete a continuous circuit around the screw terminal. There must be two separate wires on either side of the screw at the terminal block. "T-tapping" is absolutely NOT ALLOWED.

5.4 Connecting Multiple Units

Two or more HPFF8s can be connected to each other to provide additional NAC extenders for a system; see wiring in Figures 5.5–5.10. Maintain separation of power-limited and nonpower-limited wiring as discussed in Section 2.6 on page 24.



NOTE: Multiple units should not be connected in a “daisy chain” fashion. DO NOT connect a NAC output of one unit to the initiating device signal input of the next unit. The synchronization signal will not pass unimpeded through multiple units with this wiring method.

HPFF8 System Connections

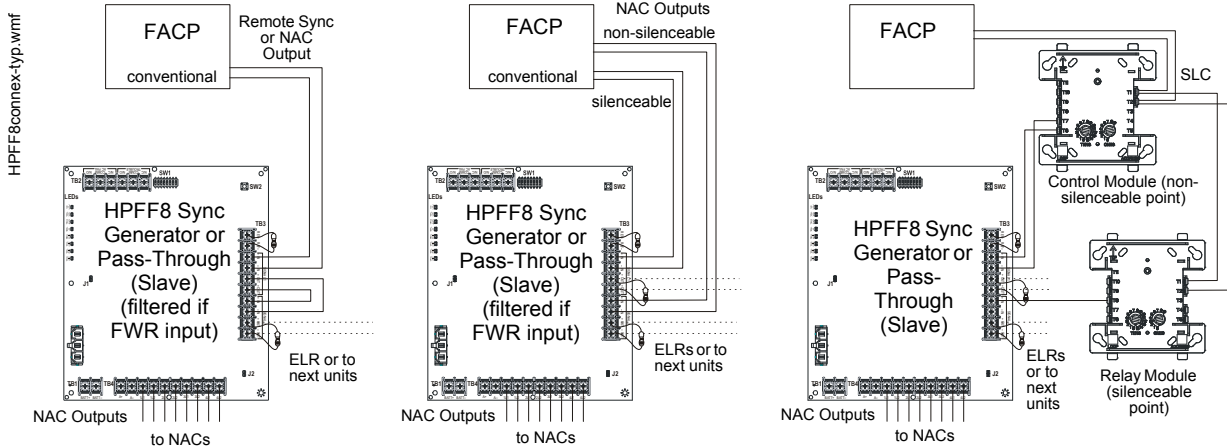

Figure 5.5 Typical System Connections

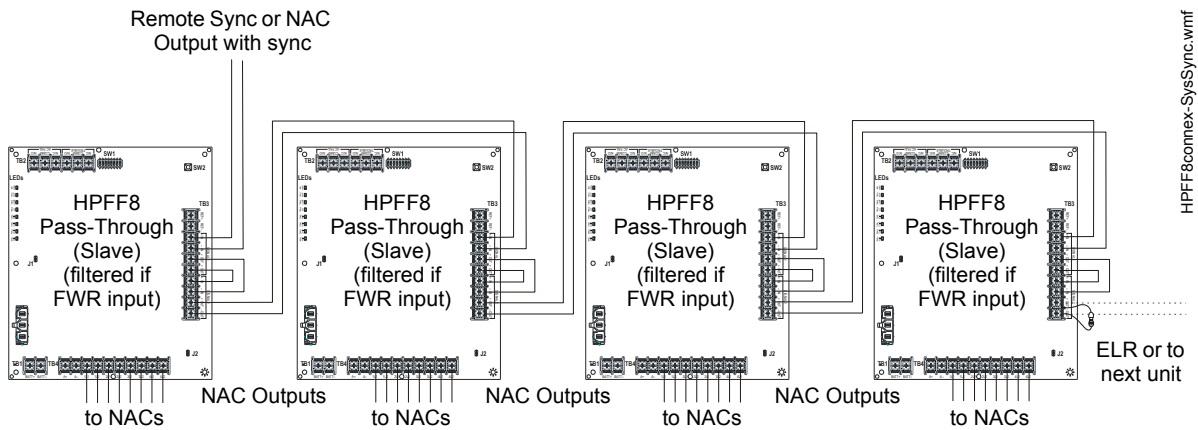

Figure 5.6 System Sync Connections

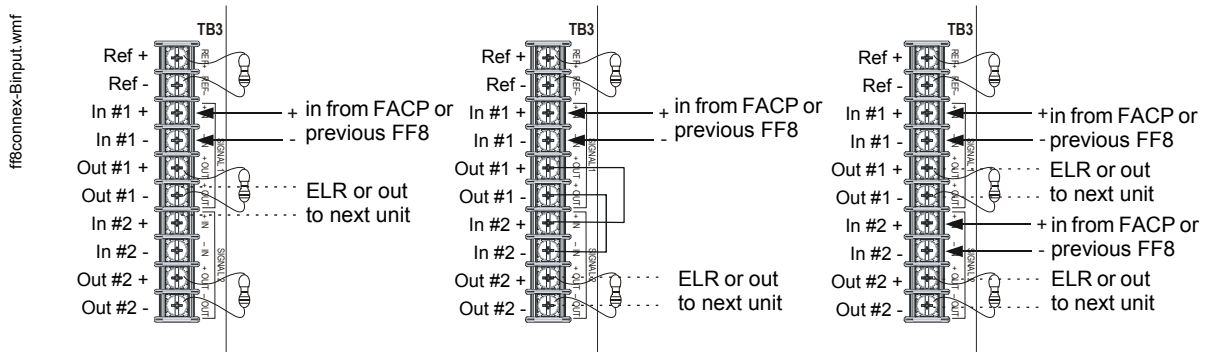

Figure 5.7 Class B Input Connections

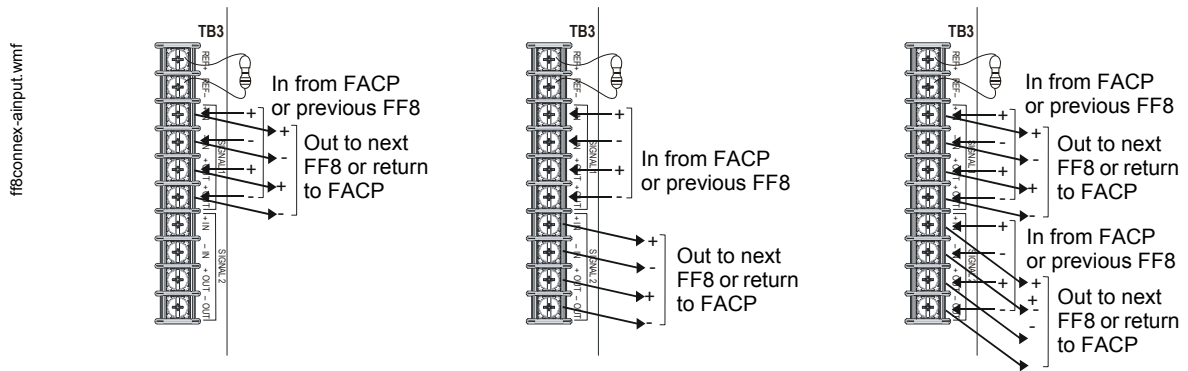

Figure 5.8 Class A Input Connections

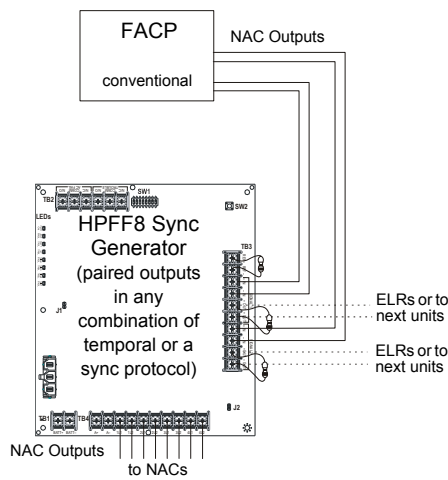

Figure 5.9 Split Alarm Connections

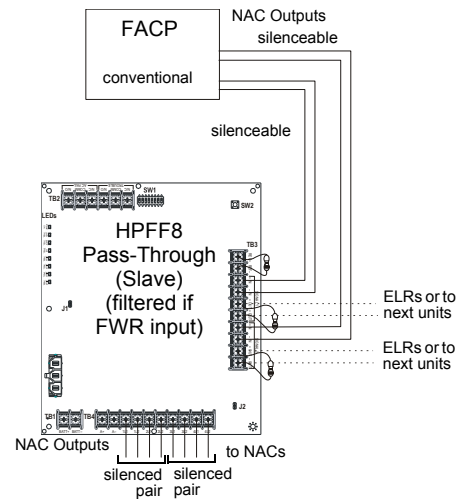

Figure 5.10 Selective Silencing Connections

Notes for Figures 5.5–5.10:

1. The FACP's NAC output must be regulated (not Full Wave Rectified [FWR]) if the HPFF8 is programmed for Sync Generator.
2. The number of possible units that can be interconnected depends on the current capability of the FACP output. Each HPFF8 input draws 12.26 mA at 24 VDC.
3. The total line impedance for interconnected units cannot be such that it creates a voltage drop > 2 VDC.
 $Z_{line\ total} = 2V / (1\ Unit + 1\ ELR)$
 Example: $Z_{line\ total} = 2V / (12.26\ mA + (24-2) / 4.7K) = 118.1\ ohms$

Notes

Section 6: Power Supply Requirements

6.1 Overview

This section contains instructions and tables for calculating power supply currents in standby and alarm conditions. This is a four step process, consisting of the following:

1. Calculating the total amount of AC branch circuit current required to operate the system
2. Calculating the power supply load current for non-alarm and alarm conditions and calculating the secondary (battery) load
3. Calculating the size of the batteries required to support the system if an AC loss occurs
4. Selecting the proper batteries for your system.

This section also contains related calculations for NAC circuits; see Section 6.5, “NAC Circuit Loop Wiring Requirements”.

6.2 Calculating the AC Branch Circuit Current

The power supply requires connection to a separate, dedicated AC branch circuit, which must be labeled FIRE ALARM. This branch circuit must be connected to the line side of the main power feed of the protected premises. No other non-fire alarm equipment may be powered from the fire alarm branch circuit. The branch circuit wire must run continuously, without any disconnect devices, from the power source to the power supply. Overcurrent protection for this circuit must comply with Article 760 of the National Electrical codes as well as local codes. Use 14 AWG (2.08 mm²) wire with 600 volt insulation for this branch circuit.

Use Table 6.1 to determine the total amount of current, in AC amperes, that must be supplied to the system.

Device Type	Number of Devices		Current Draw (AC Amps)		Total Current per Device
HPFF8/HPFF8CM			3.6 A		
or	#	X	or	=	
HPFF8E/HPFF8CME			2.1		
()	()	X	()	=	
()	()	X	()	=	
Sum Column for AC Branch Current Required					=

Table 6.1 120/240 VAC Branch Circuit Requirements

6.3 Calculating the System Current Draw

6.3.1 Overview

The power supply must be able to power all internal and external devices continuously during the non-alarm condition. To calculate the non-alarm condition load on the power supply when primary power is applied, use the Calculation Column 1 in Table 6.4. The power supply must support a larger load current during an alarm condition. To calculate the fire alarm load on the power supply, use the Calculation Column 2 in Table 6.4. The secondary power source (batteries) must be able to power the system during primary power loss. To calculate the non-alarm condition load on the power supply when primary power is applied, use the Calculation Column 3 in Table 6.4.

When calculating current draw and the battery size, note the following:

- *Primary* refers to the main AC power source for the power supply.
- *Secondary* refers to the Power supply's backup batteries.
- All currents are given in amperes (A). Table 6.2 shows how to convert milliamperes and microamperes to full amperes.

To convert...	Multiply	Example
Milliamperes (mA) to amperes (A)	mA x 0.001	3 mA x 0.001 = 0.003 A
Microamperes (µA) to amperes (A)	µA x 0.000001	300 µA x 0.000001 = 0.0003 A

Table 6.2 Converting to Full Amperes

The following table shows the maximum number of Notification Appliances that can be connected to the NAC outputs per manufacturer. These maximum numbers are equivalent to the full 12 Amps capability of the power supply. The maximum number of devices will have to be reduced if an Auxiliary load is present, see Table 6.4.

Device Manufacturer		Maximum Number of Devices
Cooper Wheelock		200 total 50 for 3.0 Amp loaded NAC
System Sensor	SpectrAlert Advanced	184 total 46 for 3.0 Amp loaded NAC
	SpectrAlert	200 total 50 for 3.0 Amp loaded NAC
Amseco		136 total 34 for 3.0 Amp loaded NAC
Faraday		132 total 33 for 3.0 Amp loaded NAC
Gentex		144 total 36 for 3.0 Amp loaded NAC

Table 6.3 Maximum Number of Notification Appliances per Extender

6.3.2 How to Calculate System Current Draw

Use Table 6.4 to calculate current draw as follows:

1. Enter the quantity of devices in all three columns.
2. Enter the current draw where required. Refer to the specifications of compatible devices for their current draw.
3. Calculate the current draws for each in all columns.
4. Sum the total current for each column.
5. Copy the totals from Column 2 and Column 3 to Table 6.4.

Following are the types of current that can be entered into Table 6.4 on page 43.

- **Calculation Column 1** — The primary AC supply current load that the power supply must support during a non-alarm condition, with AC power applied
- **Calculation Column 2** — The primary AC supply current load that the power supply must support during an alarm condition, with AC power applied
- **Calculation Column 3** — The standby current drawn from the batteries in a non-alarm condition during a loss of AC

Table 6.4 contains three columns for calculating current draws. For each column, calculate and enter the total (in amperes) in the bottom row. When finished, copy the totals from Calculation Column 2 and Calculation Column 3 to Table 6.5.

Device Type	Calculate Column 1 Primary, Non-Alarm Current (Amps RMS)		Calculate Column 2 Primary, Fire Alarm Current (DC Amps)		Calculate Column 3 Secondary, Non-Alarm Current (DC Amps)	
	Qty	X (current draw) = Total	Qty	X (current draw) = Total	Qty	X (current draw) = Total
Main Circuit Board		=[0.207]		=[0.206]		= [0.075]
Trouble Contacts (coil current)	1	X [0.0659] =	1	X [0.0659] =		= 0.0
NAC Output #1 ¹			[]	X[] =		
NAC Output #2			[]	X[] =		
NAC Output #3			[]	X[] =		
NAC Output #4			[]	X[] =		
Auxiliary Output Current Draw from TB4 ² Terminals +A & -A			[]	X[] =	[]	[] =
			[]	X[] =	[]	[] =
			[]	X[] =	[]	[] =
Sum each column for total:	Primary Non-Alarm =		Primary Alarm³=		Secondary Non-Alarm =	
1. Current limitation on TB4 NAC circuits is 3.0 Amps per NAC. 2. Current limitation on TB4 AUX Output is 2.0 Amps. 3. Total current draw cannot exceed 12.0 Amps in alarm.						

Table 6.4 System Current Draw Calculations

6.4 Calculating the Battery Size

Use Table 6.5 to calculate the total Standby and Alarm load in amperes hours (AH). This total load determines the battery size (in AH) required to support the power supply under the loss of AC. Complete Table 6.5 as follows:

1. Enter the totals from Table 6.4, Calculation Columns 2 and 3 where shown.
2. Enter the NFPA Standby and Alarm times. Refer to “NFPA Battery Requirements.”
3. Calculate the ampere hours for Standby and Alarm conditions, then sum the Standby and Alarm ampere hours.
4. Multiply the sum by the derating factor of 1.2 to calculate the proper battery size (in AH).
5. Write the ampere-hour requirements on the Protected Premises label located inside the cabinet door.

Secondary Standby Load (total from Table 6.4 Calculation Column 3) []	Required Standby Time (24 or 60 hours) X []	=	AH
Primary Alarm Load (total from Table 6.4 Calculation Column 2) []	Required Alarm Time (for 5 min., enter 0.084, for 10 min., enter 0.168) X []	=	AH
Sum of Standby and Alarm Ampere Hours		=	AH
Multiply by the Derating Factor		X 1.2	
Battery Size, Total Ampere Hours Required		=	AH

Table 6.5 Total Secondary Power Requirements at 24 VDC

6.4.1 NFPA Battery Requirements

NFPA 72 Local and Propriety Fire Alarm Systems require 24 hours of standby power followed by 5 minutes in alarm

6.4.2 Selecting and Locating Batteries

Select batteries that meet or exceed the total ampere hours calculated in Table 6.5. The power supply can charge 7 AH to 26 AH batteries.

The standard HPFF wall cabinet is capable of housing batteries up to 18 AH. Larger capacity batteries can be used if they are housed in an external UL-Listed enclosure, along with a UL-Listed battery charger with sufficient capacity to restore the full charge to the batteries in the required time. To use an external battery charger, remove the control board’s jumper at J1 CHARGER DISABLE and connect an external battery to the battery terminals on the control PCB. The alternate enclosure and battery charger shall be listed for Fire Protective Signaling use.

The HPFF8CM is a chassis mount (CM) model that can fit two 12AH batteries. It is used for a multi-pack option that allows up to four HPFF8 units mounted in large equipment enclosures.



NOTE: The HPFF8 cannot be mounted in the top position of the large equipment enclosure.

6.5 NAC Circuit Loop Wiring Requirements

Make sure these requirements are met:

1. For any NAC circuit with a full load (up to 3 Amps), the total wire resistance must be less than or equal to 0.66 Ohms.
and
2. The NAC loop current draw multiplied by total wire resistance on any single NAC circuit cannot exceed 2.0 volts.



NOTE: For loads smaller than 3 Amps, use the second calculation.

Index

A

AC branch circuit 42
AC fail 8, 9, 11, 12, 28, 29, 30, 31, 32, 33
AC fail contact rating 11
AC loss 8, 9, 11, 29, 31, 32, 42
AC power
 wiring 10, 25, 26, 27
addressable control or relay modules 22–24
applications
 connecting multiple units 39
 controlling and silencing 4 NACs 36
 four NAC circuits controlled by a single source 35
 selective silence 37
 split alarm mode 38
auxiliary output TB4 on control circuit board 11

B

backbox 13
 dimensions 13, 14, 15
batteries
 selection and placement 44
battery
 using one battery with multiple HPFFs 10
battery charging circuit (TB1 on control circuit board) 11
brownout 10
brownout (see AC loss)

C

cabinet 13, 16
 dimensions 13, 14, 15
calculating
 AC branch circuit current 42
 battery size 44
 fire alarm load 42
 power supply currents 42
 power supply requirements
 procedures 42
 system current draw 42, 43
charger disable jumper (J1) 10
chassis
 removing 13
chassis-mounting 16
class A (style Z) 20
class A (style Z) adapter 21
class B (style Y) 21
class B (style Y) 19
clearing the permanently latched overload condition 33
conduit knockouts 24
contact ratings 11
control panel circuit board 12
converting milliamperes and microamperes to full amperes 42
current draw calculations 42

D

delay 28

delayed trouble reporting 29
dimensions
 cabinet 13, 14, 15
DIP switch settings 28, 29
 selective silence 37
 split alarm and silencing 30
 split alarm mode 38
 synchronization 29

E

EQBB-D4 see cabinet
excessive loading 33

F

features 8
field programming 28
filtered feature 29
fire alarm control panel cabinet, see large equipment enclosure
form-C relay contacts (also see trouble and AC fail) 9

G

ground fault detection 33
ground fault disable jumper (J2) 10
ground monitoring 10

H

HPFF8CM installation 16
HPP31076 21

I

initiating device signal inputs (TB3 on control circuit board) 10
input/output functions 29
installation 13

J

jumpers
 charger disable (J1) 10
 ground fault disable (J2) 10
 jumper locations on control circuit board 12

L

large equipment enclosure see cabinet
latched overload condition 33
LEDs 19, 20, 21, 22
 LED diagram 12
 LED indicators 10

M

module mounting kit (P/N 90475) 22
mounting 13, 14, 16
 addressable modules 22–24
 control and relay modules (single-input) 23
 six-circuit modules 24
multi-module, see six-circuit modules

multiple units 10, 11, 39

N

NAC output circuits (TB4 on control circuit board) 11
NAC output programming 29
NAC overload protection and indication 33
NAC synchronization 29
NAC trouble memory 32
NACs
 applications 36
 maximum number per manufacturer 43
 programming 29, 30
 wiring 19–22
NFPA battery requirements 44
notification appliance circuits see NACs

O

overcurrent protection requirements 42
overload condition 33

P

pass-through feature 29
power supply circuit board 12
power-limited wiring requirements 24–27
primary power (defined) also see AC power
primary power supply (defined) 42
programming DIP switches, see Dip switch settings
programming input/output functions 29

S

secondary power supply (defined) 42
selecting and locating batteries 44
selective silence 37
semi-flush mounting 14
SIGNAL 1, SIGNAL 2 32
silencing 30
silencing, see selective silence
slave feature 29
specifications 10–12
split alarm 30
split alarm mode 38
standards 7
start-up procedure 9
style Y NACs 19, 21
style Z NACs 20
supervised
 field wiring 31
 functions 31
switch diagram 12
switches 28, 29
sync generator 29
synchronization 29
system current draw calculations 42, 43
system overview 8

T

TB3 32

TB4 11

temporal generator feature **29**

terminal block diagram **12**

trouble **8, 9, 11, 12, 29, 30, 31, 32, 33**

conditions **10**

history **32**

reporting **31–33**

trouble contact rating **11**

trouble memory **32**

trouble reporting **28**

trouble reporting delay **29**

trouble supervision **31**

troubleshooting **10, 31**

false ground faults **10**

LEDs **19, 20, 21, 22**

two-hour delay **9**

U

UL power-limited wiring requirements **24–27**

W

wall-mounting **14**

wiring

AC branch circuit **42**

also see NAC wiring

connecting multiple units **39**

control panel circuit board **12**

NAC applications **35, 36**

NACs **19, 20, 21**

separating power-limited from non-power-limited circuits **24–27**

split alarm mode **38**

system sync **39**

wire specifications **10–12**

wiring size **44**

Honeywell Power Products

12 Clintonville Road
Northford, CT 06472-1610
877.HPP.POWR
www.honeywellpower.com

53499 | B4 | 09-13
©2018 Honeywell International Inc.

Honeywell