



Control[®] 30 Three-Way High Output Indoor/Outdoor Monitor Speaker

Professional Series

Key Features:

- ▶ Extended bandwidth, extremely smooth frequency response.
- ▶ Fully outdoor-capable design, featuring WeatherMax™ multi-layer grille.
- ▶ 120° x 110° HF coverage.
- ▶ 150 Watt transformer for 70V or 100V lines, with 4Ω thru.
- ▶ SonicGuard® overload protection.
- ▶ 250 mm (10 in) fiberglass/Kevlar® cone LF woofer, with neodymium magnet coaxial 125 mm (5 in) anodized aluminum cone MR, and 25 mm (1 in) titanium diaphragm compression driver.
- ▶ Includes InvisiBall® mounting hardware, plus ten 6 mm attachment points for suspension and optional U-bracket.
- ▶ Sealed input panel cover and screw-down input terminals.

Applications

The Control 30 utilizes high power components, computer optimized horn and coaxial component design, patent-pending cabinet manufacturing techniques, and a complex network to achieve smooth high fidelity performance, extended bandwidth and well-controlled, defined coverage from a compact loudspeaker.

A symmetrical mid-high frequency horn allows use of the speaker in either vertical or horizontal orientation. Smooth frequency response and cone-midrange performance ensures excellent sound character throughout the frequency band, over the entire listening area.

The top-quality line distribution transformer, designed for minimal insertion loss and reduced saturation, allows use of either 70V or 100V distributed speaker lines. In bypass position, the 4 ohm impedance allows use of multiple speakers on a loudspeaker line.

The included InvisiBall mounting method is simple to install, aims easily and provides a high degree of theft deterrence. InvisiBall allows horizontal rotation of up to 41° off-axis and vertical rotation of up to 36° (horn end inward) or 23° (woofer end inward). Attachment points for the optional MTC-30UB (-WH) U-bracket allows for compact installation and is particularly useful for low profile underbalcony applications.

Weather resistance has been maximized. The neodymium magnet LF woofer has a fiberglass and Kevlar composite cone, the surround is pure butyl rubber, and the basket is rear loaded to minimize exposure. The MR cone of the coaxial mid-high driver is anodized aluminum with a formulation EPDM rubber surround, and the HF compression driver's diaphragm is pure titanium. The coaxial component is protected by an acoustically transparent screen. The grille is thermoset composite coated and stands up very well to UV as well as humidity. The grille is backed with our WeatherMax multi-layer foam, which prevents the direct incursion of water. Nickel/zinc rust-resistant terminals ensure a secure input connection. An MTC-PC2 sealed-entrance cover is included to further protect the speaker's terminals.

JBL's exclusive SonicGuard overload protection is virtually inaudible to the listener, ensuring reliability while providing full fidelity sound.

Available in black or white (-WH), the cabinet will accept a variety of paints to match any décor.



Specifications:

Frequency Range (-10 dB):	38 Hz – 17 kHz
Frequency Response (± 3 dB):	40 Hz – 16 kHz
100 Hr Power Capacity:	500 Watts Continuous Program Power
	250 Watts Continuous IEC Pink Noise
Maximum SPL @ 1m ³ :	Short-Term: 123 dB, Long-Term: 117 dB
Nominal Sensitivity:	93 dB, 2.83V @ 1m (3.3 ft)
Nominal Coverage Angle:	120° H x 110° V
Directivity Factor (Q):	5.2, averaged 500 Hz to 10 kHz
Directivity Index (DI):	7.1 dB, averaged 500 Hz to 10 kHz
Nominal Impedance:	4 ohms
Crossover Type:	3rd order Low Pass LF, 2nd order High Pass/3rd order Low Pass MF, 3rd order High Pass, HF, plus conjugate shaping circuitry.
Transformer Taps:	70V: 150W, 75W, 38W, 19W 100V: 150W, 75W, 38W Thru Position: 4Ω nominal
Recommended High-Pass:	See Chart
Transducers:	
Low Frequency:	250 mm (10 in) fiberglass/Kevlar® cone with pure butyl rubber surround, 50 mm (2 in) voice coil on fiberglass former, neodymium magnet
Mid Frequency:	125 mm (5 in) anodized aluminum cone with EPDM rubber (Terpolymer of Ethylene and Propylene) surround, 25 mm (1 in) voice coil on fiberglass former
High Frequency:	25 mm (1 in) compression driver, pure titanium diaphragm with patented JBL diamond surround
Physical:	
Enclosure Material:	High Impact PolyStyrene (HIPS) with 10% glass fill plus patent-pending internal 5 mm foamed polyurethane secondary mold
Grille:	Thermoset composite coated steel, WeatherMax multi-layer foam
Overload Protection:	SonicGuard full range power limiting to protect network and transducers.
Environmental:	IEC 529 IP-X5 rating. Exceeds Mil Spec 810 for humidity, salt spray, temperature & UV. Passes Mil-Std-202F for salt spray.
Termination:	Screw-down terminal strip, zinc plated copper base, nickel plated metal screws/washers. Accepts up to 9 mm outside 4 mm inside open lug (#6, #8 or #10 lug), plus bare wire (up to 12 AWG/2.5 mm ²).
Safety Agency Rating:	Transformer is listed per UL1876
Colors:	Black or white (-WH)
Dimensions (H x W x D):	593 x 372 x 345 mm (23.3 x 14.6 x 13.5 in)
Weight (ea):	18.9 kg (42 lb)
Shipping Weight (ea):	20.3 kg (45 lb)
Included Accessories:	1 pc MTC-PC2 input panel cover, InvisiBall mounting base, 6 mm x 305 mm InvisiBall Hex wrench.
Optional Accessories:	MTC-30CM (-WH) to install speaker down from the ceiling. MTC-30UB (-WH) U-Bracket

¹In Half Space

²Continuous Pink Noise rating is IEC-shaped pink noise with a 6 dB crest factor for 100 hours continuously. Continuous Program Power is defined as 3 dB above the Continuous Pink Noise Rating and is a conservative expression of the system's ability to handle normal speech and music program material.

³Calculated from sensitivity and power handling, exclusive of power compression.

⁴Half-space, averaged 100 Hz to 10 kHz

⁵500 Hz to 10 kHz

JBL continually engages in research related to product improvement. Changes introduced into existing products without notice are an expression of that philosophy.

► Control 30 Three-Way High Output Indoor/Outdoor Monitor Speaker

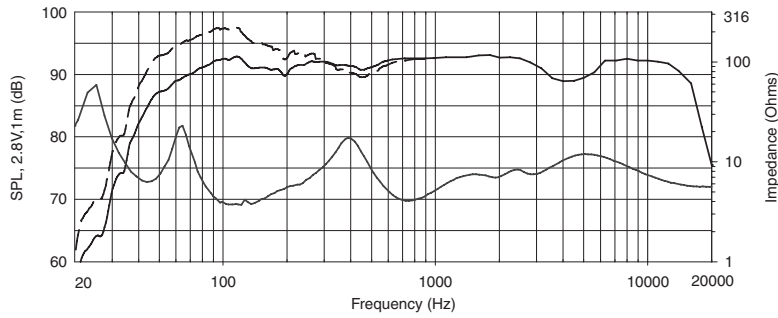

Frequency Response, on axis in half-space (2π , dotted line) and full space (4π , solid line) at thru (4Ω) setting, Input Impedance.

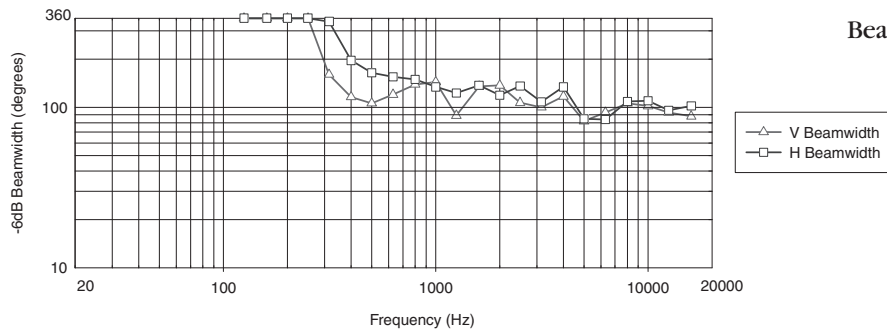

Beamwidth vs. Frequency

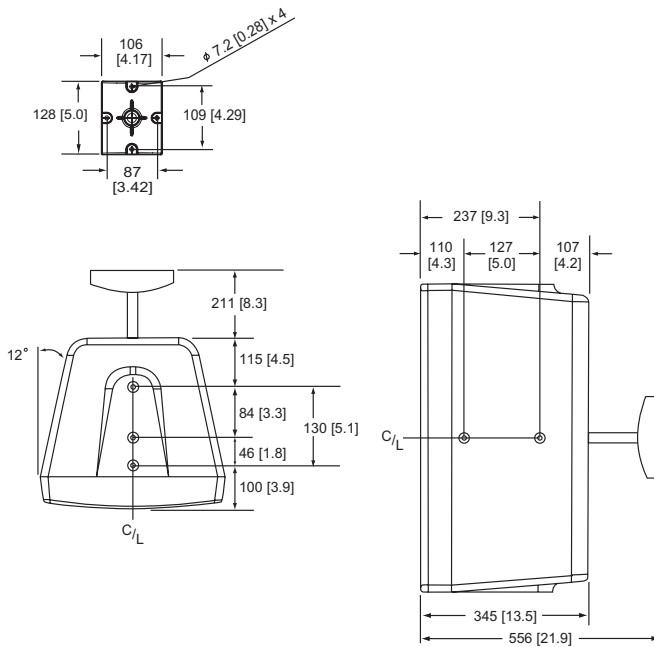

Directivity Index, Q

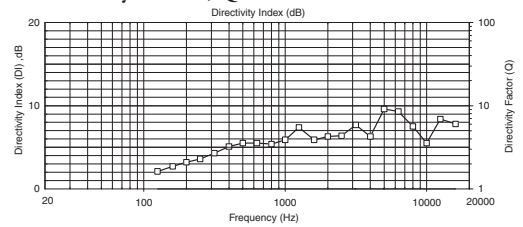

Horizontal Off Axis Frequency Response

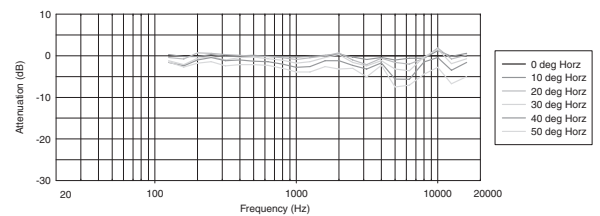

Vertical Off Axis Frequency Response (up)

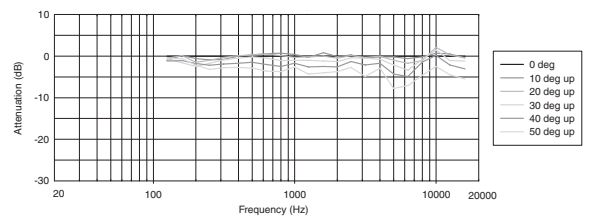

Vertical Off Axis Frequency Response (down)

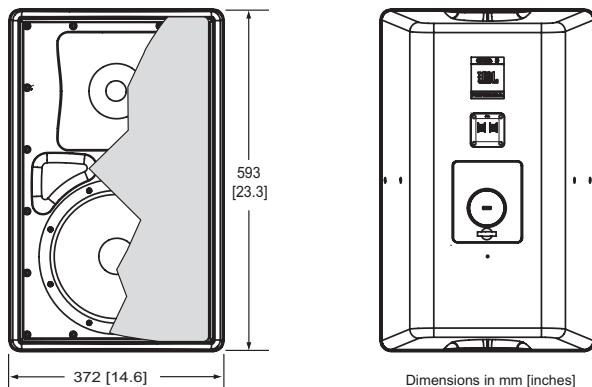
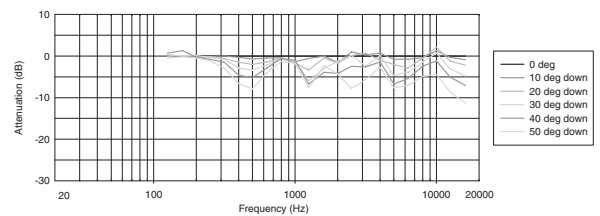

Horizontal 1/3 Octave Polars

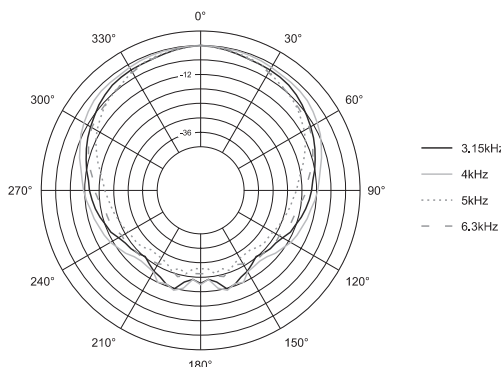
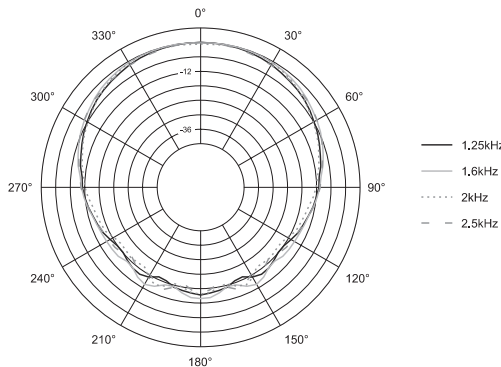
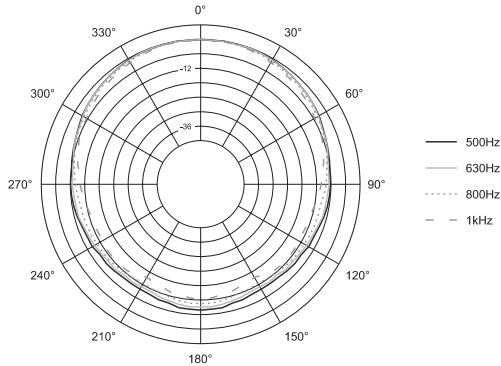
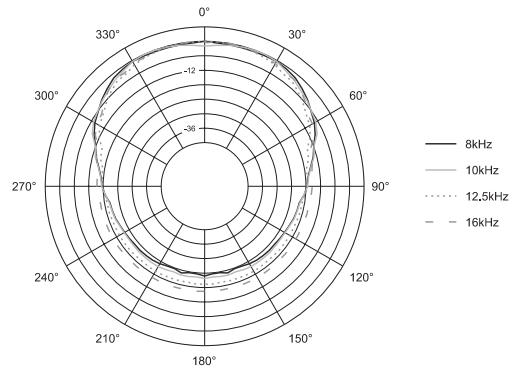
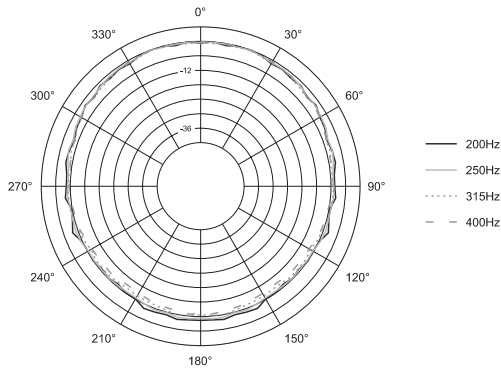

Architectural Specifications:

The loudspeaker shall consist of a 250 mm (10 in) low frequency transducer, a coaxial 125 mm (5 in) mid frequency transducer with a 25 mm (1 in) compression driver, and frequency dividing network. The low frequency driver's voice coil shall be 50 mm (2 in) in diameter and the mid frequency driver's voice coil shall be 25 mm (1 in) in diameter.

Performance specifications of a typical unit shall be as follows: Usable frequency response shall extend from 38 Hz to 17 kHz (10 dB below rated sensitivity, half-space, no external equalization). Rated power shall be at least 500 watts continuous program power for 100 continuous hours duration (defined as 3 dB above a test signal of filtered random pink noise conforming to IEC268-5). Measured sensitivity shall be at least 93 dB-SPL (at 1m [3.3 ft] with 2.83V input, avg. 100 Hz to 10 kHz).

The input shall be switchable for use either at nominal 4 ohms, or on a 70.7V or 100V distributed speaker line via built-in transformer. Selectable taps shall nominally be 150W, 75W, or 38W on a 70.7V or 100V distributed line, plus 19W on 70.7V line only.

The system shall be protected against damage from occasional over-powering via full range limiting, which shall be inaudible during activation. The coaxial mid-high driver shall be horn loaded to cover 120 degrees horizontal by 110 degrees vertical with a high degree of accuracy.

The cabinet shall be molded High Impact PolyStyrene (HIPS) with ten percent glass fill, and a 5 mm internal foamed polyurethane secondary mold. The grille shall be backed by multi-layer foam and be secured via screws to keep it in place when facing downward. The cabinet and grille shall be paintable.

The low frequency transducer shall have a neodymium magnet, a cone of woven fiberglass and Kevlar® and butyl rubber surround, with the frame protected from direct weather exposure. The mid frequency transducer element of the coaxial mid-high driver shall have an anodized aluminum cone with an EPDM rubber (a Terpolymer of Ethylene and Propylene) surround, with the frame protected from direct weather exposure. The compression driver shall be constructed with a titanium diaphragm for weather resistance. The coaxial mid-high driver shall be protected with a secondary acoustically transparent screen. The system shall withstand Mil Spec 810 testing with specified durations with no effect on its acoustical performance or structural integrity; salt spray (method 509.3), temperature (method 501.3 and 502.3), humidity (method 507.3) and ultraviolet (method 505.3). Further, it shall pass Mil-Std-202F (method 101D) for salt spray. The system shall have an IEC 529 splashproof rating of IP-X5.

For theft deterrence, the installation access area shall be hidden behind a snap-out cover on the front grille. The included ball mechanism shall be internal to the cabinet. The cabinet shall have ten (10) 6 mm mounting points including 3 on each side and 3 on top and bottom and an accessory U-bracket shall be available. The grille logo shall be rotatable for proper orientation with loudspeaker mounted horizontally or vertically.

The external wiring connectors shall be screw-down terminals. Overall cabinet dimensions shall be no greater than 593 high x 372 mm wide x 345 mm deep (23.3 x 14.6 x 13.5 in) and shall weigh no more than 18.9 kg (42 lb). The finish shall be lightly textured black or white.

The system shall be the JBL Model Control 30 (or Control 30-WH) with included InvisiBall® (mounting system).

► Control 30 Three-Way High Output Indoor/Outdoor Monitor Speaker

Vertical 1/3 Octave Polars

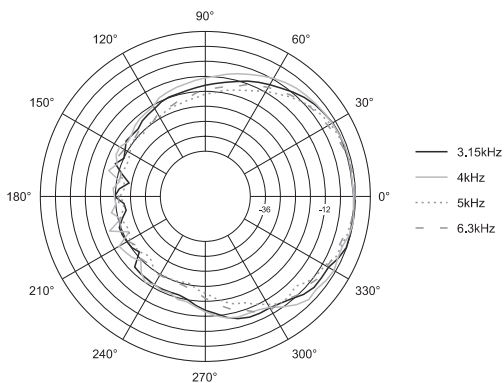
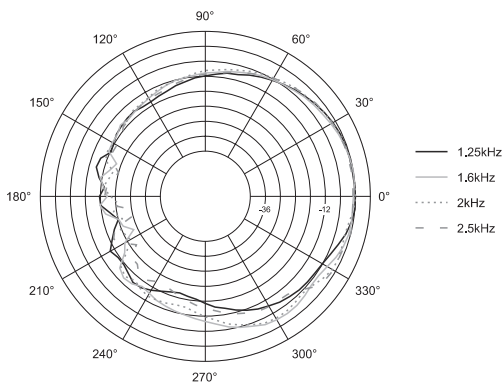
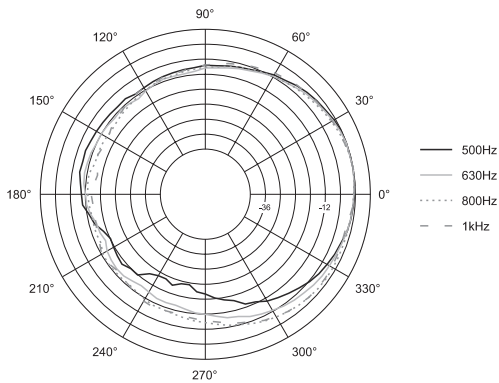
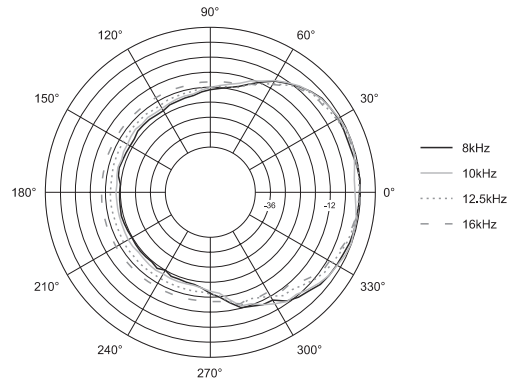
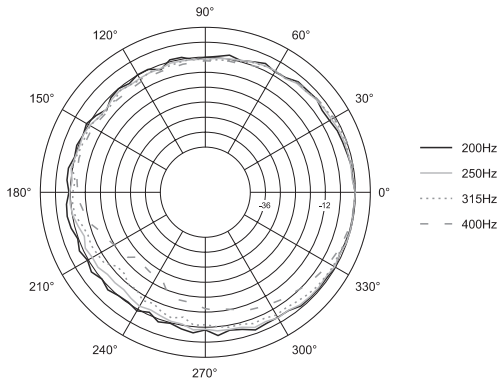

High-Pass Frequency Recommendations

The line-matching transformer in the Control 30 has been designed to minimize saturation; however, it is recommended that the system be high-passed to prevent very low-frequency content from overloading the transformer and/or the driving amplifier at high signal levels. The high-pass requirements vary according to the tap settings and number of speakers connected in parallel. The following chart will eliminate risk of saturation, even at full voltage (70V or 100V) peaks. Reducing the drive voltage will enable a corresponding reduction of high-pass frequency (24 dB/octave high-pass slope).

High Pass Recommendations for Control 30

	1 or 2 speakers	3 or more speakers
19 Watt Tap	30 Hz	35 Hz
38 Watt Tap	35 Hz	40 Hz
75 Watt Tap	60 Hz	70 Hz
150 Watt Tap	80 Hz	100 Hz
4 Ohm Setting	No High-Pass required	



JBL Professional
 8500 Balboa Boulevard, P.O. Box 2200
 Northridge, California 91329 U.S.A.

■ A Harman International Company
 © Copyright 2007 JBL Professional

SS Control 30
 CRP 5M
 07/07