

INSTRUCTION SHEET

PDS SERIES

SINGLE CIRCUIT POWER SEQUENCER



FRONT VIEW

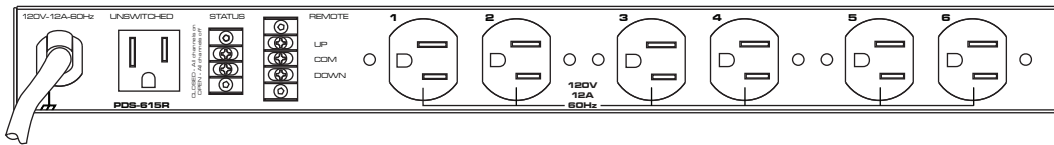

REAR VIEW

(PDS-615R Shown)

THANK YOU

Thank you for purchasing the PDS Series Single Circuit Power Sequencer. Please read these instructions thoroughly before installing this product.

PRODUCT FEATURES

- Six-step sequencing to six rear outlets
- Monitor sequencing with the front panel LED indicators
- Up to three PDS units can be daisy chained together to act as a single, 18 step unit

IMPORTANT SAFETY INSTRUCTIONS

READ AND SAVE THESE INSTRUCTIONS!
CONSERVER CES INSTRUCTIONS!

- Contains switched receptacle(s). To reduce risk of shock, disconnect the device from the power source before servicing any connected equipment

Contient de(s) receptacle(s) commuté(s). Pour réduire les risques d'électrocution, débranchez l'appareil de la source d'alimentation avant l'entretien de tout équipement connecté

- Do not overload the wall outlet where this device is being connected. Do not overload this device. Ensure the total load to this device does not exceed that which is listed in the specifications section of this manual

Ne surchargez pas le réceptacle de mur ou le circuit qui fournit l'énergie à ce appareil. Ne pas surcharger cette appareil. S'assurer que la charge totale à cet appareil ne dépasse pas celle qui est répertoriée dans la section des spécifications de ce manuel

- Ensure this device is connected to a properly grounded AC power source. Ensure the device is plugged into a source providing the required 120V. Do not use a plug adapter that defeats the ground pin of the AC plug

Assurez-vous cet appareil est connecté à une source d'alimentation C/A avec mise à la terre. Assurez-vous cet appareil est branché sur une source d'alimentation fournissant les nécessaires 120V. Ne pas utiliser un adaptateur qui contrecarre la broche de terre de la prise du cordon d'alimentation

- There are no user-serviceable components within this device. Removal of the cover from this device may present a shock hazard, and void the warranty

Il n'ya pas de composants réparables par l'utilisateur au sein de cet appareil. Retrait de la couverture de cet appareil peut présenter un danger d'électrocution et annuler la garantie

- To be used indoors in a dry location only

Pour être utilisé en intérieur dans un endroit sec seulement

- Do not operate with a damaged cord or plug

Ne pas faire fonctionner avec un cordon ou une prise endommagée

- Clean only with dry cloth

Nettoyer avec un chiffon sec seulement



DANGER HAZARDOUS VOLTAGE/DANGER HAUTE TENSION

The lightning flash with the arrowhead symbol, within an equilateral triangle is intended to alert the user to the presence of uninsulated dangerous voltage within the product's enclosure that may be of sufficient magnitude to constitute a risk of electric shock to persons.

L'éclair avec le symbole de flèche dans un triangle équilatéral est destiné à alerter l'utilisateur de la présence d'une tension dangereuse non isolée dans l'enceinte du produit qui peut être d'une ampleur suffisante pour constituer un risque de choc électrique pour les personnes.



CAUTION/ATTENTION

The exclamation point within an equilateral triangle is intended to alert the user to the presence of important operating and maintenance (servicing) instructions in the literature accompanying the appliance.

Le point d'exclamation dans un triangle équilatéral est destiné à alerter l'utilisateur de la présence d'importantes instructions d'opération et de maintenance (entretien) dans la documentation accompagnant l'appareil.

IMPORTANT NOTES

NOTE: The MAINS plug or an appliance coupler is used as the disconnect device, the disconnect device shall remain readily operable. The socket-outlet shall be installed near the equipment and shall be easily accessible.

REGULATORY COMPLIANCE

The product meets the requirements of the following standards:

- UL 60065, 7th Ed,
- CAN/CSA-C22.2 No. 60065, R2012
- UL/CSA 60950-1, 2nd Ed
- UL 1419, 3rd Ed



CONNECTIONS, CONTROLS AND INDICATORS

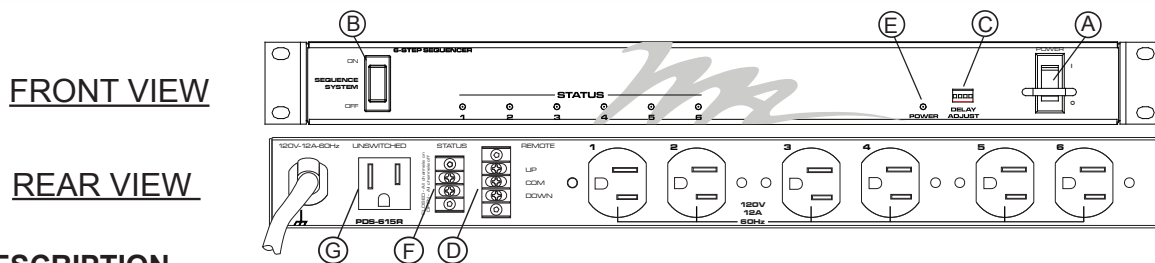

DESCRIPTION

The PDS single circuit series are power sequencers that provide sequenced AC power to 6 individual outlets located on the rear of the unit, and feature sequence interval and delay start times. The maximum cumulative load is 12 amps at 120 volts for the PDS-615R, and 16 amps at 120 volts for the PDS-620R.

(A) MASTER SWITCH:

The red Master Switch located on the front panel provides power to the control circuitry and also serves as the main circuit breaker. This switch will illuminate when in the on position and AC power is present.

(B) SYSTEM SWITCH:

This momentary switch initiates system power up and power down. When the Master Switch is on, depressing the top of this switch initiates the power up sequence, with power to each outlet indicated by the corresponding Status indicator light. The rear outlets will activate in order beginning with outlet #1 and ending with outlet #6, at a user definable interval (See DIP Switch Settings chart). Depressing the bottom of the System Switch initiates the power down sequence in reverse order, beginning with outlet #6 and ending with outlet #1. Turning the Master Switch off removes power from all outlets simultaneously, including the uncontrolled outlet ((G)) on the rear of the unit.

(C) DELAY ADJUST DIP SWITCH:

These switches allow for more complex system design by providing user control over two important functions; delay start time (the time from when the sequence is initiated to the time the first outlet receives power), and sequence interval time (how much time elapses between individual outlets receiving power). These DIP switches and the functions they control allow up to three sequencers to be "chained" together (providing up to 18 channels)

(D) REMOTE TERMINAL BLOCK:

This three position terminal block on the rear of the unit is parallel to the System Power Up/Down Switch on the front panel. An installer provided SPDT CENTER OFF (single-pole, double-throw, center position off) momentary switch can be connected for remote initiation of system sequencing. An installer provided "key" switch can also be used where extra security is required. Up to three sequencers can be controlled with one remote switch, or by the front panel system switch of the any sequencer, by wiring all Remote Terminal Blocks in parallel. (see wiring diagram)

(E) GREEN POWER INDICATOR:

This indicator lights when the Master Power Switch is on. When the Delay Start feature is selected via the Delay Adjust DIP Switches, this light will blink to indicate that the unit has received a command to initiate a sequence up or down. This light will blink for the duration of the selected delay start time. (from time sequence is initiated to the time the first outlet actually receives power).

(F) STATUS INDICATION TERMINAL BLOCK:

Dry relay contact closure closed when channels 1 through 6 are on. Contact open when channels 1 through 6 are off.

(G) 120V/12A CONVENIENCE OUTLET (NOT CONTROLLED):

On when "Master Switch" is on.

POWER

PDS-615R

- 120 Volt AC
- 12 Amp circuit
- 9' Power cord (14/3)
- Standard NEMA 5-15 plug

PDS-620R

- 120 Volt AC
- 16 Amp circuit
- 9' Power cord (12/3)
- Standard NEMA 5-20 plug

OUTPUT

- 7 Rear outputs (1 uncontrolled)
- 12 Amps total load (max PDS-615R)
- 16 Amps total load (max PDS-620R)
- 120 Volt AC

PROGRAMMING

- Sequence delay start and interval between outlets timing functions controlled via front mounted dip switch.

DIMENSIONS

- 19" Wide
- 1.75" High (1 space)
- 8.75" Deep

CONSTRUCTION

- 18 Gauge steel
- Black powder coat finish

INTERCONNECTION

- Rear remote control terminal block provides remote system power up/down. Multiple units may be chained together via simple parallel control wiring.
- Rear status terminal block, indicates sequence complete. (Relay contact closure)

PROTECTION

- 15 (PDS-615R) or 20 (PDS-620R) Amp circuit breaker located on front panel. (master switch)

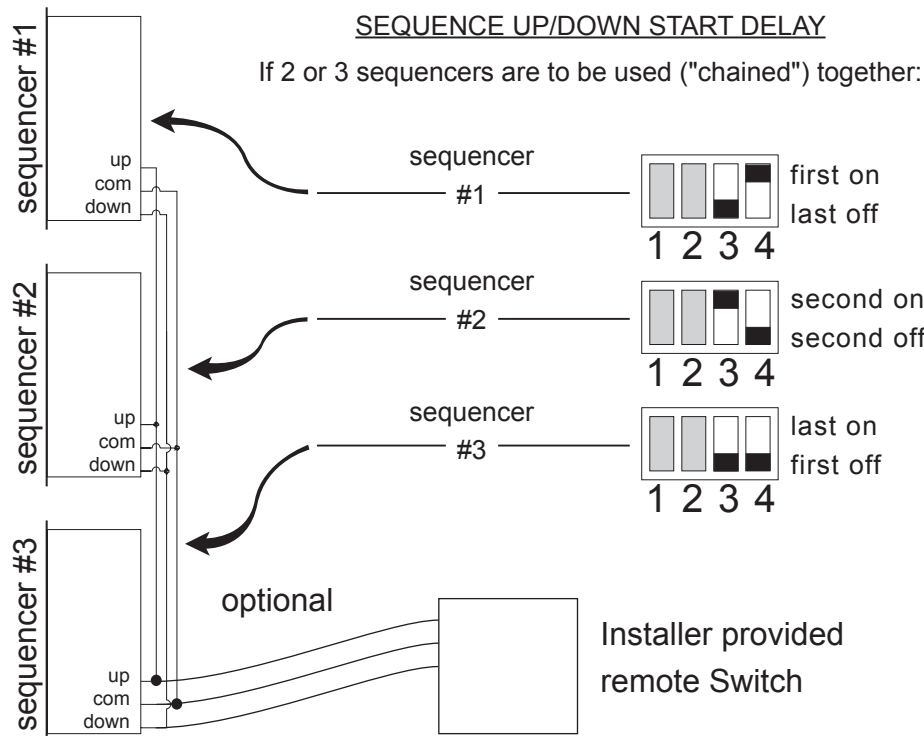

DIP SWITCH SETTINGS:

DELAY BETWEEN SEQUENCES

.75 second interval between each outlet power up/down



1.5 second interval between each outlet power up/down



2.25 second interval between each outlet power up/down



7 second interval between each outlet power up/down



- 1) Wire all rear terminal blocks in parallel, for multiple sequence operation.
- 2) Front system power up/down switch is wired in parallel with rear remote terminal block. When wired together as shown, pressing front System Power UP/DOWN switch on ANY sequencer will initiate system sequencing.
- 3) If remote power UP/DOWN is required, wire dry contacts in parallel. (single pole, double throw, center off, momentary switch)
- 4) Initiating system sequencing remotely: Sequencing can be initiated by either momentary dry contact or maintained dry contact. Use of a maintained dry contact for system power up will reinitiate sequence after power is restored from a power outage. When using maintained (not momentary) dry contact for remotely controlling system sequencing, the front System Power UP/DOWN switches will be over-ridden.

NOTE: A flashing power (green) LED indicates that the system sequencing has begun.



Middle Atlantic Products

what great systems are built on™

middleatlantic.com ■ 800.266.7225

WARRANTY

Middle Atlantic Products (the "Company") warrants the PDS Power Series Single Circuit Power Sequencer to be free from defects in material or workmanship under normal use and conditions for a period of (3) years from the date of shipment by the company.

The Company's entire liability to the purchaser, and the purchaser's (or any other party's) sole and exclusive remedy, under this warranty shall be limited, at the Company's option, to either (a) return of and refund of the price paid for, or (b) repair or replacement at the Company's factory of the products purchased, or any part or parts thereof, which the Company has determined to be defective after inspection thereof at the Company's factory.

This warranty does not cover damage due to acts of God, accident, misuse, abuse or negligence by parties other than the Company, or any modification or alteration of the products. In addition, this warranty does not cover damage due to improper handling, assembly, installation or maintenance.

THIS WARRANTY IS IN LIEU OF ALL OTHER WARRANTIES OF ANY KIND, EITHER EXPRESSED OR IMPLIED, INCLUDING, BUT NOT LIMITED TO, IMPLIED WARRANTIES OF MERCHANTABILITY AND FITNESS FOR A PARTICULAR PURPOSE.

TO THE MAXIMUM EXTENT PERMITTED BY APPLICABLE LAW, IN NO EVENT SHALL THE COMPANY BE LIABLE FOR ANY SPECIAL, INCIDENTAL, INDIRECT, OR CONSEQUENTIAL DAMAGES WHATSOEVER (INCLUDING, WITHOUT LIMITATION, DAMAGES FOR LOSS OF BUSINESS PROFITS, BUSINESS INTERRUPTION OR ANY OTHER PECUNIARY LOSS) ARISING OUT OF THE USE OF THE PRODUCTS PURCHASED, EVEN IF THE COMPANY HAS BEEN ADVISED OF THE POSSIBILITY OF SUCH DAMAGES. THE COMPANY'S LIABILITY TO THE PURCHASER (OR ANY OTHER PARTY) HEREUNDER, IF ANY, SHALL IN NO EVENT EXCEED THE PURCHASE PRICE OF THE PRODUCTS PAID TO THE COMPANY.

Corporate Headquarters

Corporate Voice 973-839-1011 - Fax 973-839-1976 / International Voice +1 973-839-8821 - Fax +1 973-839-4982
middleatlantic.com - info@middleatlantic.com

Middle Atlantic Canada

Voice 613-836-2501 - Fax 613-836-2690 / middleatlantic.ca - customerservicecanada@middleatlantic.ca

Factory Distribution

USA: NJ - CA - IL Canada: ON - BC

At Middle Atlantic Products we are always listening. Your comments are welcome.

Middle Atlantic Products is an ISO 9001 and ISO 14001 Registered Company.