

Operation Instructions

PDC Series

CONTROLLED POWER CENTER



FRONT VIEW

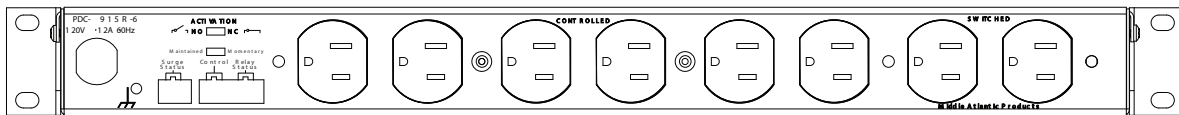

REAR VIEW

(PDC-915R-6 Shown)

THANK YOU

Thank you for purchasing the PDC Series Controlled Power Center.

IMPORTANT SAFETY INSTRUCTIONS

READ AND SAVE THESE INSTRUCTIONS!
CONSERVER CES INSTRUCTIONS!

- Contains switched receptacle(s). To reduce risk of shock, disconnect the device from the power source before servicing any connected equipment

Contient de(s) receptacle(s) commuté(s). Pour réduire les risques d'électrocution, débranchez l'appareil de la source d'alimentation avant l'entretien de tout équipement connecté

- Do not overload the wall outlet where this device is being connected. Do not overload this device. Ensure the total load to this device does not exceed that which is listed in the specifications section of this manual

Ne surchargez pas le réceptacle de mur ou le circuit qui fournit l'énergie à cet appareil. Ne pas surcharger cet appareil. S'assurer que la charge totale à cet appareil ne dépasse pas celle qui est répertoriée dans la section des spécifications de ce manuel

- Ensure this device is connected to a properly grounded AC power source. Ensure the device is plugged into a source providing the required 120V. Do not use a plug adapter that defeats the ground pin of the AC plug

Assurez-vous cet appareil est connecté à une source d'alimentation C/A avec mise à la terre. Assurez-vous cet appareil est branché sur une source d'alimentation fournissant les nécessaires 120V. Ne pas utiliser un adaptateur qui contrecarre la broche de terre de la prise du cordon d'alimentation

- There are no user-serviceable components within this device. Removal of the cover from this device may present a shock hazard, and void the warranty

Il n'ya pas de composants réparables par l'utilisateur au sein de cet appareil. Retrait de la couverture de cet appareil peut présenter un danger d'électrocution et annuler la garantie

- To be used indoors in a dry location only

Pour être utilisé en intérieur dans un endroit sec seulement

- Do not operate with a damaged cord or plug

Ne pas faire fonctionner avec un cordon ou une prise endommagée

- Clean only with dry cloth

Nettoyer avec un chiffon sec seulement

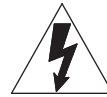

DANGER HAZARDOUS VOLTAGE/DANGER HAUTE TENSION

The lightning flash with the arrowhead symbol, within an equilateral triangle is intended to alert the user to the presence of uninsulated dangerous voltage within the product's enclosure that may be of sufficient magnitude to constitute a risk of electric shock to persons.

L'éclair avec le symbole de flèche dans un triangle équilatéral est destiné à alerter l'utilisateur de la présence d'une tension dangereuse non isolée dans l'enceinte du produit qui peut être d'une ampleur suffisante pour constituer un risque de choc électrique pour les personnes.



CAUTION/ATTENTION

The exclamation point within an equilateral triangle is intended to alert the user to the presence of important operating and maintenance (servicing) instructions in the literature accompanying the appliance.

Le point d'exclamation dans un triangle équilatéral est destiné à alerter l'utilisateur de la présence d'importants instructions d'opération et de maintenance (entretien) dans la documentation accompagnant l'appareil.

IMPORTANT NOTES

NOTE: The MAINS plug or an appliance coupler is used as the disconnect device, the disconnect device shall remain readily operable. The socket-outlet shall be installed near the equipment and shall be easily accessible.

REGULATORY COMPLIANCE

The product meets the requirements of the following standards:

- UL 60065, 7th Ed,
- CAN/CSA-C22.2 No. 60065, April 2003, R2012
- UL/CSA 60950-1, 2nd Ed
- UL 1419, 3rd Ed



CONNECTIONS, CONTROLS AND INDICATORS

FRONT PANEL FUNCTIONS



- ① Control Status LED: Yellow LED indicates control switch is AUTO
- ② Control Status LED: Green LED indicates controlled receptacles are ON
- ③ Master On/Off Circuit Breaker Switch (**Factory Position OFF**)
- ④ Control Switch: (AUTO-OFF-ON) (**Factory Position OFF**)
- ⑤ Surge Status LEDs (Green): There is one LED for each surge stage, protected when lit
- ⑥ NEMA 5-15R Single Switched Receptacle

REAR PANEL FUNCTIONS

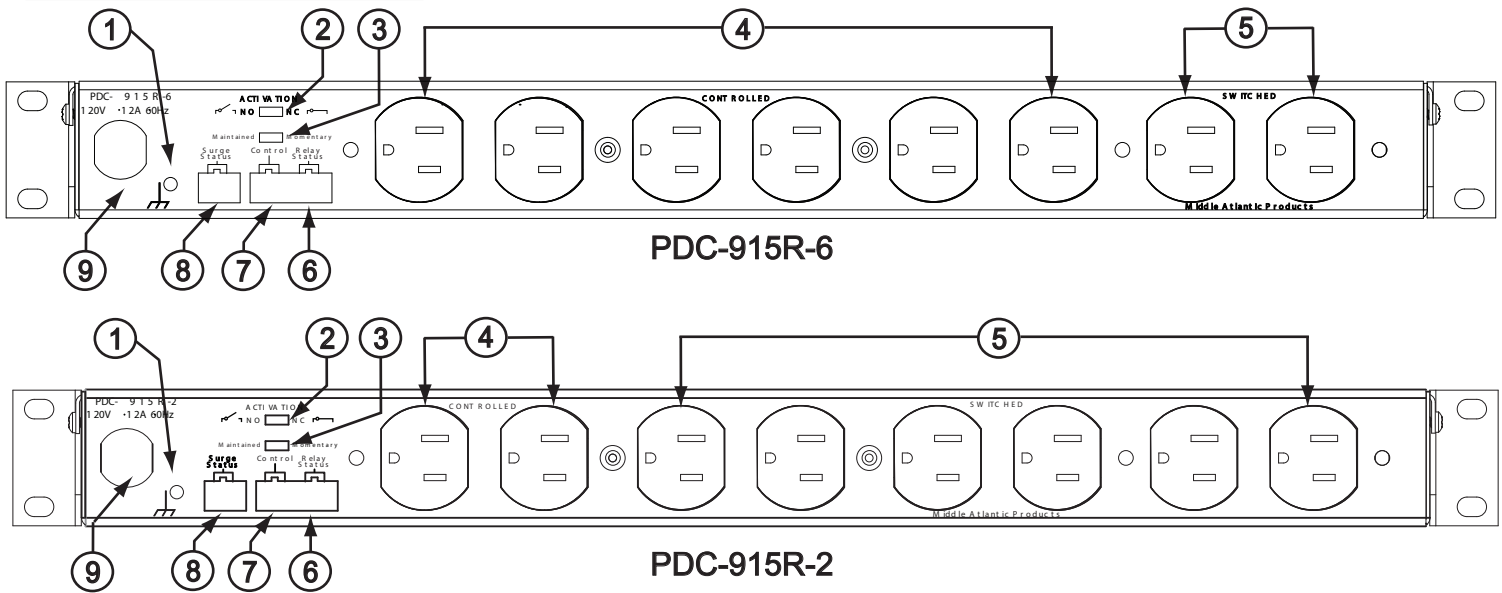

- ① External Grounding/Bonding Stud
- ② “Normally Open” or “Normally Closed” control selection switch
- ③ “Momentary” or “Maintained” control selection switch
- ④ NEMA 5-15R Controlled Receptacles
- ⑤ NEMA 5-15R Switched Receptacles
- ⑥ Controlled Outlet Status Terminal Block
- ⑦ Remote Control Terminal Block provides connection of dry contact (customer provided closure)
- ⑧ Surge Status: provides remote notification of surge status (customer provided closure)
- ⑨ Signal-Safe™ Power Cord

FUNCTIONALITY REQUIREMENTS

The MASTER SWITCH/CB must be on for the receptacles to receive power. Once in the ON position, the unswitched receptacles will receive power as will the control and surge suppression circuits.

The controlled receptacles receive power via the control circuits under the following conditions:

A) The AUTO-OFF-ON switch is in the ON position.

B) The AUTO-OFF-ON switch is in the AUTO position with the NORMALLY OPEN/CLOSED control selector switch in the NORMALLY OPEN position and there is a contact closure on the remote control terminal block.

C) The AUTO-OFF-ON switch is in the AUTO position with the NORMALLY OPEN/CLOSED control selector switch in the NORMALLY CLOSED position and there is no contact closure on the remote control terminal block.

CONTACT CLOSURE OPERATION

The customer provided contact closure connected to remote control terminal block, can be either momentary or maintained. The MOMENTARY/MAINTAINED selector switch must be in the proper position. The terminal block control closure is ignored when the AUTO-OFF-ON switch is in the ON or OFF position.

MOMENTARY OPERATION

A contact closure is required for the control PCB to process the control signal. Each subsequent closure will alternately turn off and on the power to the controlled receptacles. NOTE: Power cycling the unit via the MASTER SWITCH will cause the controlled receptacles to revert to the OFF position.

MAINTAINED OPERATION

With the NORMALLY OPEN/CLOSED switch in the NORMALLY OPEN position, a maintained contact closure will energize the controlled receptacles via the control circuit. When this maintained contact is removed, the receptacles will become de-energized. With the NORMALLY OPEN/CLOSED switch in the NORMALLY CLOSED position, a maintained contact closure will de-energize the controlled receptacles via the control circuit. When this maintained contact is removed, the receptacles will become energized.

CONTROLLED OUTLET TERMINAL BLOCK:

The Controlled Outlet Terminal Block provides status of controlled outlets via a dry contact. The CLOSED position indicates the controlled receptacles are energized, while the OPEN position indicates that the controlled receptacles are de-energized.

SURGE SUPPRESSION (2 STAGE):

There are two green LED indicators on the front panel indicating the condition of the protection circuitry.

There is one LED for each of the two stages. Any protective component failure will be indicated by the LEDs being turned off.

In addition to the LEDs, surge suppression component failure will be indicated by a dry contact closure via the rear terminal block.

WARRANTY

Middle Atlantic Products (the "Company") warrants the PDC Series to be free from defects in material or workmanship under normal use and conditions for a period of three (3) years from the date of shipment by the company.

The Company's entire liability to the purchaser, and the purchaser's (or any other party's) sole and exclusive remedy, under this warranty shall be limited, at the Company's option, to either (a) return of and refund of the price paid for, or (b) repair or replacement at the Company's factory of the products purchased, or any part or parts thereof, which the Company has determined to be defective after inspection thereof at the Company's factory.

This warranty does not cover damage due to acts of God, accident, misuse, abuse or negligence by parties other than the Company, or any modification or alteration of the products. In addition, this warranty does not cover damage due to improper handling, assembly, installation or maintenance.

THIS WARRANTY IS IN LIEU OF ALL OTHER WARRANTIES OF ANY KIND, EITHER EXPRESSED OR IMPLIED, INCLUDING, BUT NOT LIMITED TO, IMPLIED WARRANTIES OF MERCHANTABILITY AND FITNESS FOR A PARTICULAR PURPOSE.

TO THE MAXIMUM EXTENT PERMITTED BY APPLICABLE LAW, IN NO EVENT SHALL THE COMPANY BE LIABLE FOR ANY SPECIAL, INCIDENTAL, INDIRECT, OR CONSEQUENTIAL DAMAGES WHATSOEVER (INCLUDING, WITHOUT LIMITATION, DAMAGES FOR LOSS OF BUSINESS PROFITS, BUSINESS INTERRUPTION OR ANY OTHER PECUNIARY LOSS) ARISING OUT OF THE USE OF THE PRODUCTS PURCHASED, EVEN IF THE COMPANY HAS BEEN ADVISED OF THE POSSIBILITY OF SUCH DAMAGES. THE COMPANY'S LIABILITY TO THE PURCHASER (OR ANY OTHER PARTY) HEREUNDER, IF ANY, SHALL IN NO EVENT EXCEED THE PURCHASE PRICE OF THE PRODUCTS PAID TO THE COMPANY.

Corporate Headquarters

Corporate Voice 973-839-1011 - Fax 973-839-1976

International Voice +1 973-839-8821 - Fax +1 973-839-4982

middleatlantic.com - info@middleatlantic.com

Middle Atlantic Canada

Voice 613-836-2501 - Fax 613-836-2690

middleatlantic.ca - customerservicecanada@middleatlantic.ca

Factory Distribution

USA: NJ - CA - IL Canada: ON - BC

At Middle Atlantic Products we are always listening. Your comments are welcome. Middle Atlantic Products is an ISO 9001 and ISO 14001 Registered Company.