





INSTALLATION INSTRUCTIONS PD-715SC-NS HALF RACK POWER STRIP

PARTS LIST

<u>HRF MOUNTING BRACKET</u>		<u>QTY</u> 2	<u>PART</u> A
<u>HRF MOUNTING BRACKET TRUSS HEAD SCREW</u>		<u>QTY</u> 2	<u>PART</u> B
<u>POWER STRIP CLIP</u>		<u>QTY</u> 2	<u>PART</u> C
<u>POWER STRIP CLIP FLAT HEAD SCREW</u>		<u>QTY</u> 2	<u>PART</u> D
<u>POWER STRIP</u>		<u>QTY</u> 1	<u>PART</u> E

NOTE: Parts (A) and (B) are only for use with the HRF Series Half Rack. Parts (C) and (D) are in a separate bag, stretch wrapped to the power strip (E).

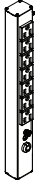
1) Install mounting hardware into fixed holes as shown (top and bottom of the rack).

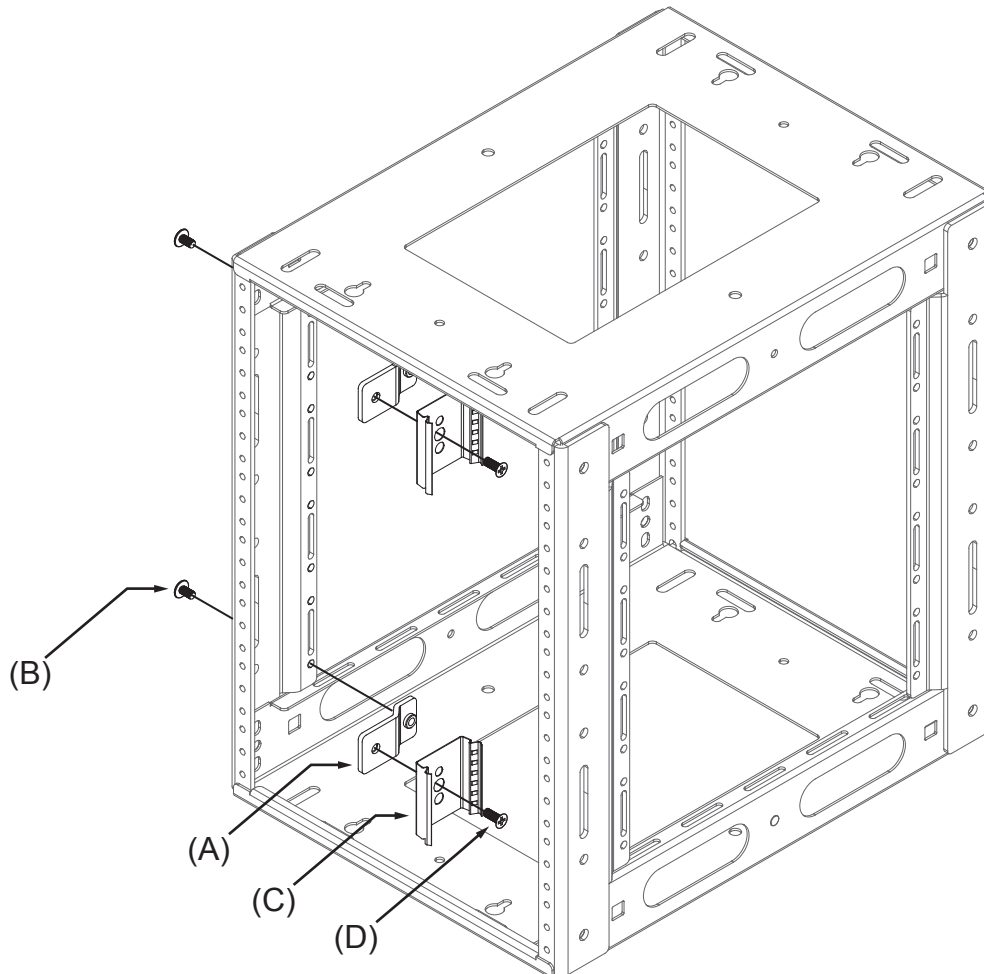

- 2) Align the power strip with the mounting clips and snap into place. Make sure the circuit breaker at the end of the power strip is accessible.

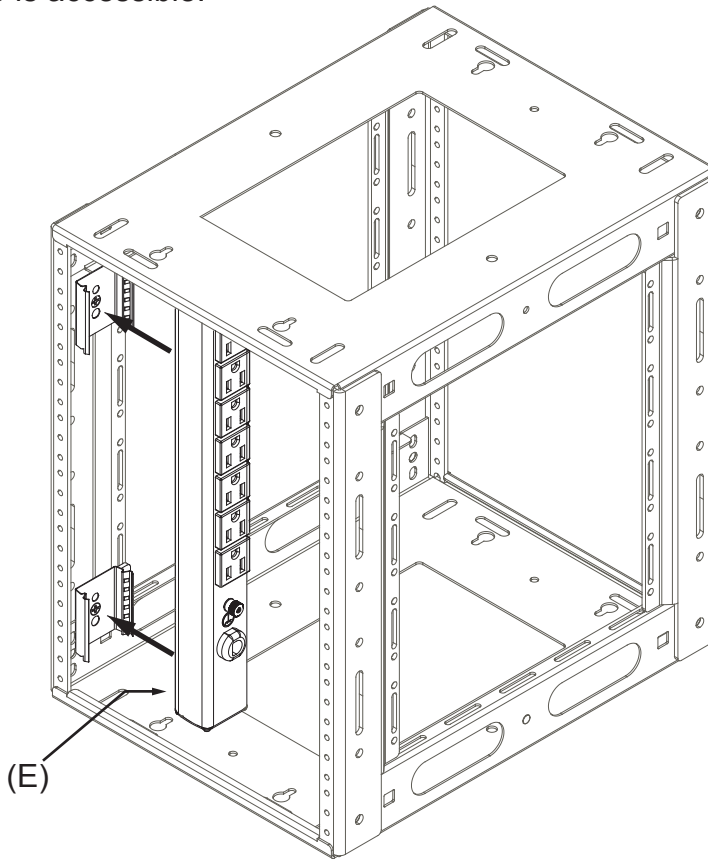

TIP: To remove the power strip from the mounting clips, wedge a flat tip screwdriver between side of power strip and clip, gently prying the power strip from the clip.

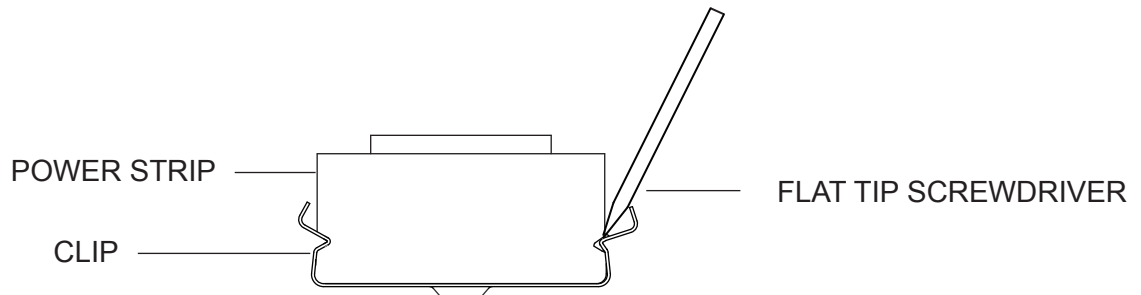

WARRANTY

Middle Atlantic Products (the "Company") warrants the PD-715SC-NS to be free from defects in material or workmanship under normal use and conditions for a period of (3) years from date of shipment by the Company.

The Company's entire liability to the purchaser, and the purchaser's (or any other party's) sole and exclusive remedy, under this warranty shall be limited, at the Company's option, to either (a) return of and refund of the price paid for, or (b) repair or replacement at the Company's factory of the products purchased, or any part or parts thereof, which the Company has determined to be defective after inspection thereof at the Company's factory. This warranty does not cover damage due to acts of God, accident, misuse, abuse or negligence by parties other than the Company, or any modification or alteration of the products. In addition, this warranty does not cover damage due to improper handling, assembly, installation or maintenance.

THIS WARRANTY IS IN LIEU OF ALL OTHER WARRANTIES OF ANY KIND, EITHER EXPRESSED OR IMPLIED, INCLUDING, BUT NOT LIMITED TO, IMPLIED WARRANTIES OF MERCHANTABILITY AND FITNESS FOR A PARTICULAR PURPOSE.

TO THE MAXIMUM EXTENT PERMITTED BY APPLICABLE LAW, IN NO EVENT SHALL THE COMPANY BE LIABLE FOR ANY SPECIAL, INCIDENTAL, INDIRECT, OR CONSEQUENTIAL DAMAGES WHATSOEVER (INCLUDING, WITHOUT LIMITATION, DAMAGES FOR LOSS OF BUSINESS PROFITS, BUSINESS INTERRUPTION OR ANY OTHER PECUNIARY LOSS) ARISING OUT OF THE USE OF THE PRODUCTS PURCHASED, EVEN IF THE COMPANY HAS BEEN ADVISED OF THE POSSIBILITY OF SUCH DAMAGES. THE COMPANY'S LIABILITY TO THE PURCHASER (OR ANY OTHER PARTY) HEREUNDER, IF ANY, SHALL IN NO EVENT EXCEED THE PURCHASE PRICE OF THE PRODUCTS PAID TO THE COMPANY.

Corporate Headquarters

Corporate Voice 973-839-1011 - Fax 973-839-1976 / International Voice +1 973-839-8821 - Fax +1 973-839-4982
middleatlantic.com - info@middleatlantic.com

Middle Atlantic Canada

Voice 613-836-2501 - Fax 613-836-2690 / middleatlantic.ca - customerservicecanada@middleatlantic.ca

Factory Distribution

USA: NJ - CA - IL Canada: ON - BC

At Middle Atlantic Products we are always listening. Your comments are welcome.