



**SISTP1040-342-LRT**



**SISTP1040-382-LRT**

## SISTP10x0-3xx-LRT Series Unmanaged Hardened Gigabit Ethernet PoE+ Switches

### Install Guide

## Intellectual Property

© 2021-2022 Lantronix, Inc. All rights reserved. No part of the contents of this publication may be transmitted or reproduced in any form or by any means without the written permission of Lantronix.

*Lantronix* is a registered trademark of Lantronix, Inc. in the United States and other countries.

Patented: <https://www.lantronix.com/legal/patents/>; additional patents pending.

## Warranty

For details on the Lantronix warranty policy, go to our web site at <http://www.lantronix.com/support/warranty>.

## Contacts

### Lantronix Corporate Headquarters

7535 Irvine Center Drive  
Suite100  
Irvine, CA 92618, USA  
Toll Free: 800-526-8766  
Phone: 949-453-3990  
Fax: 949-453-3995

### Technical Support

Online: <https://www.lantronix.com/technical-support/>

### Sales Offices

For a current list of our domestic and international sales offices, go to [www.lantronix.com/about/contact](http://www.lantronix.com/about/contact).

## Disclaimer

All information contained herein is provided "AS IS." Lantronix undertakes no obligation to update the information in this publication. Lantronix does not make, and specifically disclaims, all warranties of any kind (express, implied or otherwise) regarding title, non-infringement, fitness, quality, accuracy, completeness, usefulness, suitability or performance of the information provided herein. Lantronix shall have no liability whatsoever to any user for any damages, losses and causes of action (whether in contract or in tort or otherwise) in connection with the user's access or usage of any of the information or content contained herein. The information and specifications contained in this document are subject to change without notice.

## Revision History

Date	Rev.	Comments
7/2/18	B	Add FCC and CID2 information.
7/14/20	C	Change power supply 25080 to 25105, update RJ45 LED description, add caution on DC power supply earth grounding and add note on switch and Power Supply 25105/25104 earth grounding, update DoC, add WMBH-01 and remove reference to UI.
9/15/20	D	Clarify Terminal Block / switch power on and Power Supply information. Update compliance information.
6/30/21	E	Update product label information and features.
7/28/21	F	Update Safety certification from EN60950 or IEC60950 to IEC62368-1/EN62368-1. Update DoC.
4/18/22	G	Add IEEE 802.3bt Power Input Ripple and Noise Specification. Initial Lantronix rebrand. Update DoC.

## Safety Warnings and Cautions

These products are not intended for use in life support products where failure of a product could reasonably be expected to result in death or personal injury. Anyone using this product in such an application without express written consent of an officer of Lantronix does so at their own risk and agrees to fully indemnify Lantronix for any damages that may result from such use or sale.



**Attention:** this product, like all electronic products, uses semiconductors that can be damaged by ESD (electrostatic discharge). Always observe appropriate precautions when handling.



**NOTE:** Emphasizes important information or calls your attention to related features or instructions.



**WARNING:** Alerts you to a potential hazard that could cause personal injury.



**CAUTION:** Alerts you to a potential hazard that could cause loss of data or damage the system or equipment.

## Contents

Safety Warnings and Cautions .....	3
About This Manual .....	5
Related Information .....	5
Key Features .....	5
Ordering Information .....	5
Specifications .....	6
Front Panel.....	10
Back and Bottom Panels.....	10
RESET Button .....	11
Installation and Setup.....	12
Unpacking/ Package Contents.....	12
Switch Mounting Options .....	12
Mounting the Switch on a Wall (Optional).....	12
Mounting the Switch on a DIN Rail .....	13
Install and Connect SFPs via Fiber Optic Cable.....	14
Connect PoE+ Ports via TP Copper Cable .....	14
PoE / PoE+ Spec Comparison .....	15
IEEE 802.3bt Power Input Ripple and Noise Specification.....	15
Grounding.....	16
Power Supply Features and Specifications .....	17
Industrial Power Supply 25105 .....	17
Industrial Power Supply 25104 .....	18
Connecting to Power.....	19
Adjusting Power Supply Output Voltage (+V ADJ) .....	19
LED Descriptions.....	20
Troubleshooting.....	22
General Troubleshooting.....	22
LED Summary .....	22
LED Troubleshooting .....	23
PoE Modes and Compliance.....	23
Troubleshooting PoE Problems .....	25
Declaration of Conformity.....	27
User Information.....	27
Cautions and Warnings.....	28

## Product Description

The SISTP10x0-3xx-LRT series industrial unmanaged GbE switches are plug-and-play Ethernet switches offering an easy way to make the transition to Gigabit Ethernet and increase the speed of your network connection. They are energy efficient, built to last, and rigorously tested to provide the reliability businesses need, and they are suitable for industrial Ethernet applications. The SISTP10x0-3xx-LRT series includes two PoE+ models: SISTP1040-342-LRT and SISTP1040-382-LRT. The series offers various port combinations all with PoE+ budget, to meet different requirements in various applications.

## About This Manual

This manual describes how to install, configure, and troubleshoot the SISTP10x0-3xx-LRT switches. It also describes how to determine LED meanings and how to reset the switch.

## Related Information

A printed Quick Start Guide is shipped with each SISTP10x0-3xx-LRT. For Lantronix Drivers, Firmware, Manuals, Brochures, Data Sheets, etc. go to the Lantronix [Technical Resource Center](#). For SFP manuals see the Lantronix [SFP webpage](#). **Note:** Information in this document is subject to change without notice. Note that this manual provides links to third party web sites for which Lantronix is not responsible.

## Key Features

- Slim type industrial switch
- IEEE 802.3af/at Power over Ethernet
- IEEE 802.3az Energy Efficient Ethernet standard for green Ethernet application
- Flow Control
- Support Jumbo Frame up to 9K bytes
- Layer 2 wire-speed switching engine
- Ruggedized metal closure
- IEEE 802.3az Energy Efficient Ethernet
- Fan-less design
- Wide operating temperature range (-40°C to +75°C)
- Dual Power input
- Din Rail and Wall Mount options

## Ordering Information

Model	Description
<b>SISTP1040-342-LRT</b>	Unmanaged Industrial PoE+ Switch, (4) 10/100/1000Base-T PoE+ Ports+ (2) 100/1000Base-X SFP Ports
<b>SISTP1040-382-LRT</b>	Unmanaged Industrial PoE+ Switch, (8) 10/100/1000Base-T PoE+ Ports with (2) 100/1000Base-X SFP Ports
<b>Optional Accessories</b> (sold separately)	
<b>25105</b>	Optional Industrial Power Supply for SISTP1040-342-LRT; sold separately.
<b>25104</b>	Optional Industrial Power Supply for SISTP1040-342-LRT and SISTP1040-382-LRT; sold separately.
<b>SFP Modules</b>	SFP modules sold separately (see Lantronix SFP <a href="#">Product Selector</a> page)
<b>WMBH-01</b>	Optional Wall Mount Bracket; sold separately.
<b>DRBH-01</b>	Optional Din Rail Bracket; sold separately.
<b>OCA-P181610</b>	Optional 18x16x10" Polycarbonate Enclosure; sold separately.

## Specifications

### Port Configuration

Model	Total Ports	RJ45 (10M/100M/1G)	SFP (100M/1G)	Console	Available PoE Power
SISTP1040-342-LRT	6	4	2	--	120W
SISTP1040-382-LRT	10	8	2	--	240W

### Hardware Performance

Model	Forwarding Capacity (Mpps)	Switching Capacity (Gbps)	Mac Table (K)	Jumbo Frames (Bytes)
SISTP1040-342-LRT	8.928	12	4	9K
SISTP1040-382-LRT	14.88	20	4	9K

### Environmental Ranges

Operating Temperature		Storage Temperature		Operating Humidity	Altitude	
Fahrenheit	Centigrade	Fahrenheit	Centigrade	5% to 95% non- condensing	Feet	Meters
-40 to 167	-40 to 75	-40 to 185	-40 to 85		< 10000	<3000

### Dimensions, Weights, Mounting

Model	Dimension (WxHxD)*		Weight		Mounting Type
	Millimeters	Inches	Kilograms	Pounds	
SISTP1040-342-LRT	44x 135x 130	1.7x 5.3x 5.1	0.43	0.94	DIN rail, Wall
SISTP1040-382-LRT	44x 135x 130	1.7x 5.3x 5.1	0.46	1.01	DIN rail, Wall

\* Dimensions shown above are without the DIN rail bracket and power plug installed.  
The dimensions are 1.7x 5.3x 5.9" with the DIN rail bracket and power plug installed.

### Voltage and Frequency

Primary Power Supply - DC Input Voltage	
DC Nominal	48 VDC dual inputs
DC Operating Range	48 to 57 VDC

**PoE Power Capacity**

Model	Available PoE Power	Number of Ports That Support PoE (15.4W) and PoE+ (30.0W)
SISTP1040-342-LRT	120W	Each of port 1 - 4 support PoE/ PoE+ within available PoE Power
SISTP1040-382-LRT	240W	Each of port 1 - 8 support PoE/ PoE+ within available PoE Power

**Certifications**

EMS Compliance		
IEC 61000-4-2 (ESD)	Contact 8K	Air 15KV
IEC 61000-4-3 (RS)	3V/m	
IEC 61000-4-4 (EFT)	Power ports and telecommunication ports 0.5KV	Signal ports 0.25KV
IEC 61000-4-5 (SURGE)	Line to line 0.5KV Line to ground 1.0KV	
IEC 61000-4-6 (CS)	Voltage Level 129.5 dB(uV) (3.0V)	
IEC 61000-4-2 (PFMF)	1 A/m	A

**Regulatory Compliance**

EMI	FCC Part 15 Class A
Safety	CE, IEC62368-1/EN62368-1
CI/D2	CI/D2
<b>Mechanical Stability</b>	
Vibration	IEC 60068-2-6
Shock	IEC 60068-2-27
Freefall	IEC 60068-2-32

**MTBF**

Model	MTBF	Environment
SISTP1040-342-LRT	1,052,267 Hrs.	GB, GC - Ground Benign, Controlled. Temp: 25.00 deg. C.
	188,587 Hrs.	GB, GC - Ground Benign, Controlled. Temp: 75.00 deg. C.
SISTP1040-382-LRT	1,043,630 Hrs	GB, GC - Ground Benign, Controlled. Temp: 25.00 deg. C.
	156,272 Hrs.	GB, GC - Ground Benign, Controlled. Temp: 75.00 deg. C.

**DC Power Consumption****SISTP1040-382-LRT****1. DC 52V Input (SISTP1040-382-LRT)**

Status	Operation Interface	DC Current Consumption (A)	DC Voltage (V)	DC Power Consumption (W)
Non-loading	None	0.07	52	3.64
Standby mode	1G TP Port x 8 1G SFP Port x 2	4.55	52	236.60
Full-loading 60 minutes later *	1G TP Port x 8 1G SFP Port x 2	4.55	52	236.60

**2. DC 57V Input (SISTP1040-382-LRT)**

Status	Operation Interface	DC Current Consumption (A)	DC Voltage (V)	DC Power Consumption (W)
Non-loading	None	0.07	57	3.99
Standby mode	1G TP Port x 8 1G SFP Port x 2	4.10	57	233.70
Full-loading 60 minutes later *	1G TP Port x 8 1G SFP Port x 2	4.10	57	233.70

\* DC power consumption measured after 60 minutes under full loading with wire speed forwarding.



**SISTP1040-342-LRT****1. DC 52V Input (SISTP1040-342-LRT)**

Status	Operation Interface	DC Current Consumption (A)	DC Voltage (V)	DC Power Consumption (W)
Non-loading	None	0.07	52	3.64
Standby mode	1G TP Port x 4 1G SFP Port x 2	2.29	52	119.08
Full-loading 60 minutes later	1G TP Port x 4 1G SFP Port x 2	2.29	52	119.08

**2. DC 57V Input (SISTP1040-342-LRT)**

Status	Operation Interface	DC Current Consumption (A)	DC Voltage (V)	DC Power Consumption (W)
Non-loading	None	0.07	57	3.99
Standby mode	1G TP Port x 4 1G SFP Port x 2	2.08	57	118.56
Full-loading 60 minutes later	1G TP Port x 4 1G SFP Port x 2	2.08	57	118.56

\* DC power consumption measured after 60 minutes under full loading with wire speed forwarding.

## Front Panel

The SISTP1040-382-LRT front panel is shown below.

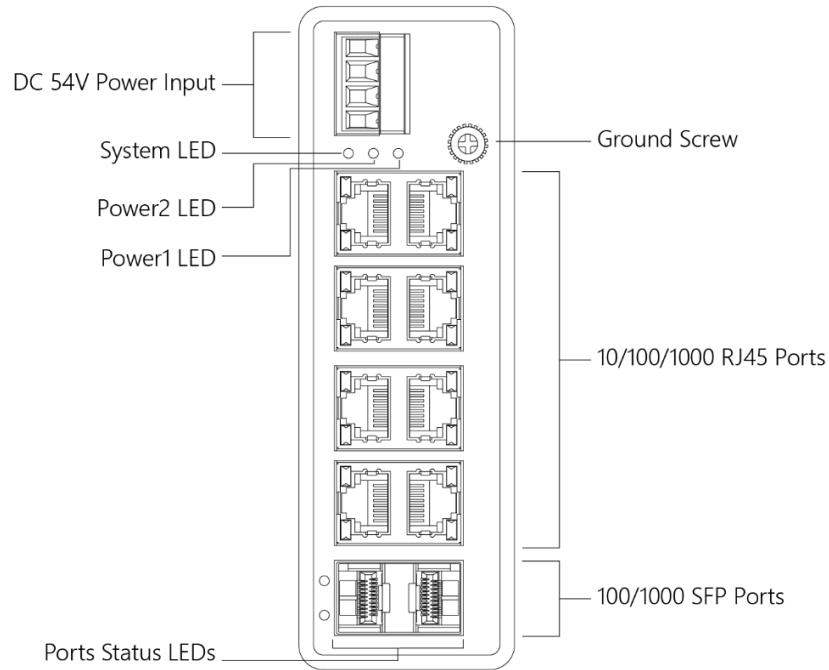

## Back and Bottom Panels

The SISTP1040-382-LRT back and bottom panels are shown below.

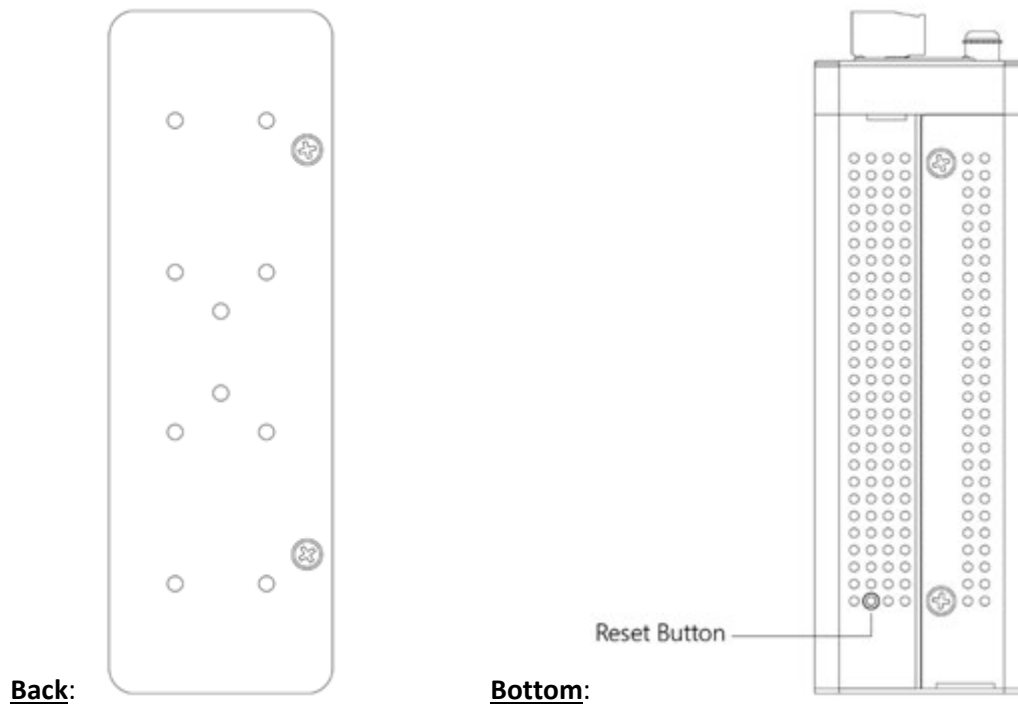

## RESET Button

You can press the bottom panel **RESET** button to reboot the switch.



## Installation and Setup

### Unpacking/ Package Contents

Carefully unpack the switch. Please save the packing material for possible future use. Make sure you have received these items:

- One Switch with Terminal Block attached
- One printed Quick Start Guide
- Four rubber feet
- One Power Supply (optional – sold separately)

Contact your sales representative if any item is missing or damaged.

### Switch Mounting Options

The Switch can be installed in these ways:

- Wall mounted
- DIN Rail

#### Mounting the Switch on a Wall (Optional)

1. Attach the wall mounting plates to rear panel of the chassis. Insert screws and tighten with a screwdriver to secure the plates.

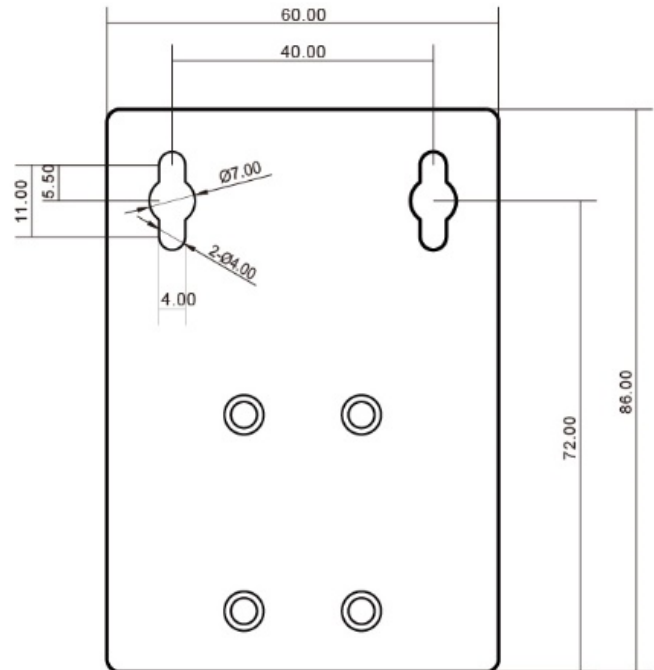
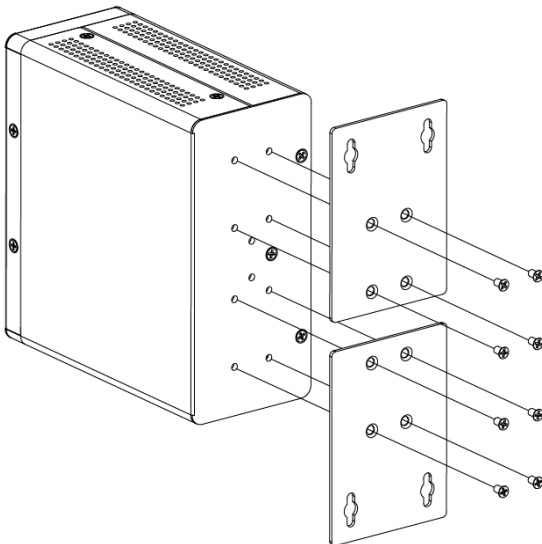

2. Install user-supplied screws on the appropriate location on the wall.
3. Make sure that the switch is attached securely to wall.

## Mounting the Switch on a DIN Rail

1. Attach the DIN Rail mounting kit to the rear panel of the chassis. Insert screws and tighten with a screwdriver to secure the kit.

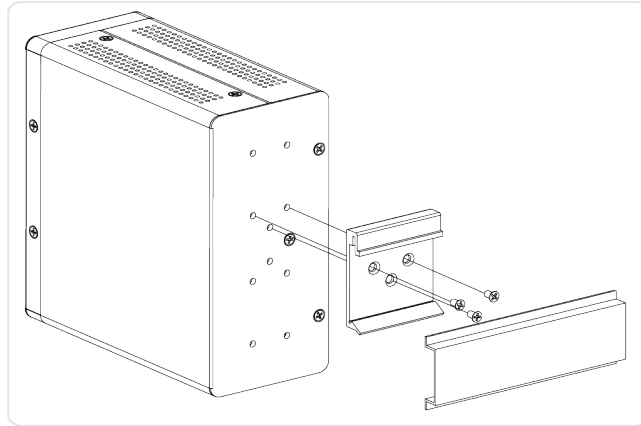

2. Insert the upper lip of the DIN rail into the DIN-rail mounting kit and press the switch towards the DIN rail until it snaps into place.

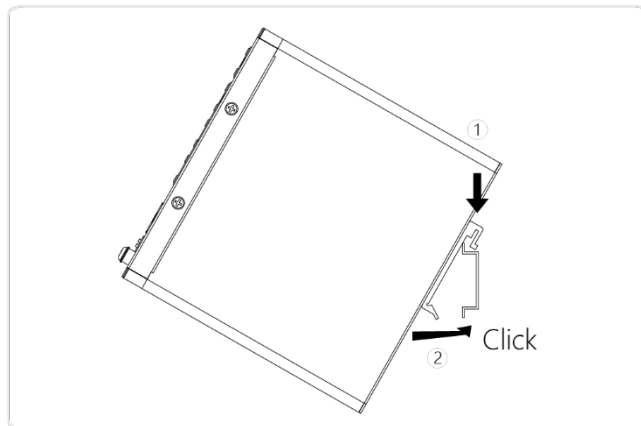

3. Make sure that the switch is attached securely to DIN Rail.

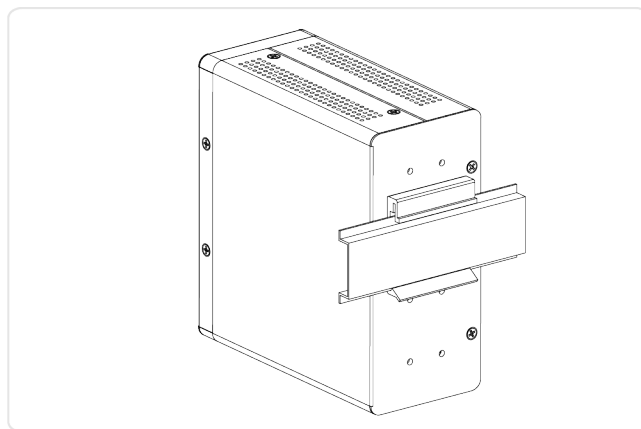

**Note:** Make all cable connections and perform grounding before connecting to power.

## Install and Connect SFPs via Fiber Optic Cable

The Switch lets you install a Small Form-Factor Pluggable (SFP) device of your choice to make a fiber connection via the 100/1000Base-X SFP Ports. See the Lantronix [SFP page](#) for SFP models. See the related SFP manual for safety precautions and warnings specific to your SFP model. The SFP ports should use UL Listed Optional Transceiver products, Rated 3.3Vdc, Laser Class 1.

1. Prepare a fiber optic cable with an appropriate connector. **Warning:** The fiber optic port contains a Class 1 laser device. When the ports are disconnected, always cover them with the provided plug. Exposed fiber optic ports may cause skin or eye damage.
2. Remove a rubber plug from the Switch and position the SFP device at an SFP slot with the label facing correctly.
3. Carefully slide the SFP device into the slot, aligning it with the internal installation guides. Ensure that the SFP device is firmly seated against the internal mating connector.
4. See the related SFP manual for operating information specific to your particular SFP model.
5. Connect the other end of the cable to the appropriate far end Ethernet port.

**Note:** After the cable is properly connected at both ends, the Switch LED should be functional. See [LED Descriptions](#) on page 20 for a description of LED operation.

See the related online [SFP manual](#) for operating information specific to your particular SFP model.

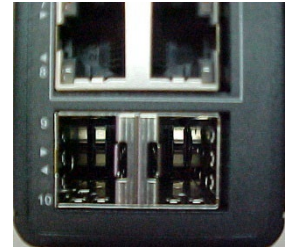

## Connect PoE+ Ports via TP Copper Cable

The Switch also provides 10/100/1000Base-T.

**Supported cabling:** PoE per IEEE 802.3af PoE supports Cat 3 and Cat 5. PoE per IEEE 802.3at PoE+ supports Cat 5. See “[PoE / PoE+ Spec Comparison](#)” on page 15 for more PoE/PoE+ information.

1. Prepare a twisted-pair copper cable.
2. Connect one end of the cable to the Switch.
3. Connect the other end of the cable to a PD, such as a VoIP phone.

**Note:** After the cable is properly connected at both ends, the Switch **SYS** LED should be functional. See [LED Descriptions](#) on page 20 for LED operation details.

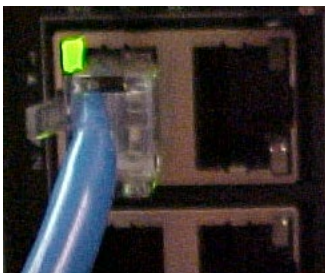

## PoE / PoE+ Spec Comparison

PoE Plus (PoE+) provides extended support for new end devices with higher power requirements. The IEEE 802.3at standard provides up to 30W of power to include newer end devices such as IEEE 802.11n wireless access points, security surveillance cameras, etc.

Property	802.3af PoE	802.3at PoE+
Power Available at PD	12.95 W	25.50 W
Max. Power from PSE	15.40 W	30.0 W
Voltage Range (at PSE)	44.0 – 57.0 V	50.0 – 57.0 V
Voltage Range (at PD)	37.0 – 57.0 V	42.5 – 57.0 V
Max. current	350 mA	600 mA per mode
Max. cable resistance	20 ohms (Cat 3)	12.5 ohms (Cat 5)
Power management	3 power class levels negotiated at 1 <sup>st</sup> connection	4 power class levels negotiated at 1 <sup>st</sup> connection or 0.1 W steps negotiated continuously
Supported cabling	Cat 3 and Cat 5	Cat 5
Supported modes	Mode A (endspan) and Mode B (midspan)	Mode A and Mode B

## IEEE 802.3bt Power Input Ripple and Noise Specification

$f < 500$ Hz	$V_{\text{Noise}}$	$V_{\text{pp}}$	0.5
500 Hz to 150 kHz			0.2
150 kHz to 500 kHz			0.15
500 kHz to 1 MHz			0.1

## Grounding

After the Switch is mounted and connected, the front panel grounding screw () can be used for grounding. Grounding and wire routing help limit the effects of noise due to electromagnetic interference (EMI). Run the ground connection from the ground screw to the grounding surface before connecting devices.



**ATTENTION:** This case must be earth grounded. No DC input may be earth grounded. Use Isolated Power Supply.



**Warning:** Minimum input 57 VDC. Check polarity first!

**Note:** When input rating is 48 – 51 V DC, each PoE port output is 15 W max. When input rating is 51 - 57 V DC, each PoE port output is 30 W max.

**Note:** Both the switch and Power Supply 25105 / 25104 must have their ground terminals connected to earth ground.

**Caution:** Tying the output connection of the DC power supply to earth ground to create an earth referenced voltage power supply will violate the power supply isolation to earth ground requirements of IEEE 802.3af/at/bt. If an earth grounded power supply is utilized, all connected equipment to this power source must then be tied to same local earth ground as the power supply source. Failure to maintain a common earth ground potential for all nodes on the power distribution network can cause equipment damage due to high voltage ground differences between the connected equipment. It is recommended that the power supply connections for PoE networks not be tied to earth ground.



## Power Supply Features and Specifications

The Industrial Power Supplies (25104 and 25105) are optional accessories (sold separately).

- 25104 Input: 85-264 VAC, 124-370 VDC. Output: 48~55 VDC, 5.0A, 240 Watts.
- 25105 Input: 85-264 VAC, 124-370 VDC. Output: 48~55 VDC, 2.5A, 120 Watts.

### Industrial Power Supply 25105

#### Output

Output Voltage	48VDC
Current Rating	2.5A
Power Rating	120 Watts
Ripple & Noise Max	120mVp-p
Voltage Range	48~55VDC
Voltage Tolerance	±1.0%
Line Regulation	±0.5%
Load Regulation	±1.0%
Setup, Rise Time	1500ms, 60ms
Hold Up Time	20ms

#### Input

Voltage Range	Switch Selectable 88~264VAC 124~370VDC
Frequency Range	47~63Hz
Efficiency	90.5%
AC Current (Typical)	1.4A@115VAC 0.7A@230VAC
Inrush Current (Cold)	35A@115VAC 70A@230VAC Leakage Current <1.0mA@240VAC

#### Protection

Overload	110~150%
Overvoltage	56~65V
Over Temperature	95°C±5°C

#### Environment

Operating Temp. -25°C~+70°C. Storage Temp. -40°C~+85°C. Operating Humidity: 20~95% non-condensing.

#### Features

91% High Efficiency.	150% Peak Load.
Protected against:	Short Circuit, Overload, Over Voltage, Overheating.
Convection air cooling.	DIN rail mountable. RoHS compliant. MTBF 298.9 Khrs.
Dimensions (mm):	40W, 125.2H, 113.5D. Weight .67Kg.

#### Standards

Safety: UL508, TUV EN60950-1. Vibration: IEC60068-2-6

EMC Emission: EN55011, EN55022, CISPR22 Class B, EN61000-3-2, |EN61000-3-3.

EMC Immunity: EN61000-4-2, EN61000-4-3, EN61000-4-4, EN61000-4-5, EN61000-4-6, EN61000-4-8, EN61000-4-11, EN55024, EN61000-6-2, EN50082-2, EN61204-3, SEMI F47, GL Approved.

**Note:** Both the switch and the power supply must have their ground terminals connected to earth ground.



## Industrial Power Supply 25104

### Output

Output Voltage	48VDC
Current Rating	5A
Power Rating	240 Watts
Ripple & Noise Max	120mVp-p
Voltage Range	48~55VDC
Voltage Tolerance	±1.0%
Line Regulation	±0.5%
Load Regulation	±1.0%
Setup, Rise Time	300ms, 60ms
Hold Up Time	20ms

### Input

Voltage Range	Switch selectable. 88~132VAC. 124~370VDC
Frequency Range	47~63Hz
Efficiency	94%
AC Current (Typical)	2.6A@115VAC. 1.3A@230VAC
Inrush Current (Cold)	33A@115VAC. 65A@230VAC

**Protection** Overload 105~160%. Overvoltage 56~65V.

### Environment

Operating Temp.	-25°C~+70°C.
Storage Temp.	-40°C~+85°C.
Operating Humidity	20~95% non-condensing

### Features

94% High Efficiency. 150% Peak Load. Protected against: Short Circuit, Overload, Over Voltage, Overheating. Convection air cooling. RoHS compliant. MTBF 169.3 Khrs.  
 `Dimensions (mm): 63W, 125.2H, 113.5D. Weight 1.03Kg.

### Standards

Safety: UL508, TUV EN60950-1. Vibration: IEC60068-2-6. EMC Emission: EN55022, CISPR22 Class B, EN61000-3-2, |EN61000-3-3. EMC Immunity: EN61000-4-2, EN61000-4-3, EN61000-4-4, EN61000-4-5, EN61000-4-6, EN61000-4-8, EN61000-4-11, EN55024, EN61000-6-2, EN50082-2, EN61204-3, SEMI F47, GL Approved.

**Description:** Mean Well SDR-240-48. **INPUT:** 100-240VAC 2.6A 50/60 Hz.

**OUTPUT:** 48V - 5A. "Use copper wire only". "Maximum surrounding air temperature: 60°C". "Instructions for installation in a pollution degree 2 environment".

**Terminal Torque:** 7 Lb-in (DC connections at top of PS). **Terminal Torque:** 4.4 Lb-in (AC connections at bottom of PS).

**+V ADJ:** access to small Phillips screw; turn clockwise to increase voltage. Adjustable, 48-55V.

**DC OK LED:** lights to indicate a DC OK condition.

With just the DC supply connected the **ALM** (Alarm) LED lights in Red.

**Note:** Both the switch and the power supply must have their ground terminals connected to earth ground.



## Connecting to Power

After the Switch is mounted, connected, and grounded, use the Terminal Block (Euro Block) to provide DC Power Inputs P1 and P2.

**Warning:** Connect the wires to the terminal block before plugging power into the Switch product. Plug the Terminal Block into the switch before powering on.

1. Insert the negative/positive DC wires into the **V-** and **V+** terminals, respectively.
2. To keep the DC wires from pulling loose, use a small flat-blade screwdriver to tighten the wire-clamp screws on the front of the Terminal Block connector.
3. Plug the Power adapter plug into AC power at an appropriate AC outlet.
4. Check the **SYS** LED. If it is ON, the power connection is correct.



## Adjusting Power Supply Output Voltage (+V ADJ)

**+V ADJ:** access to small Phillips screw; turn clockwise to increase voltage. Adjustable, 48-55V.

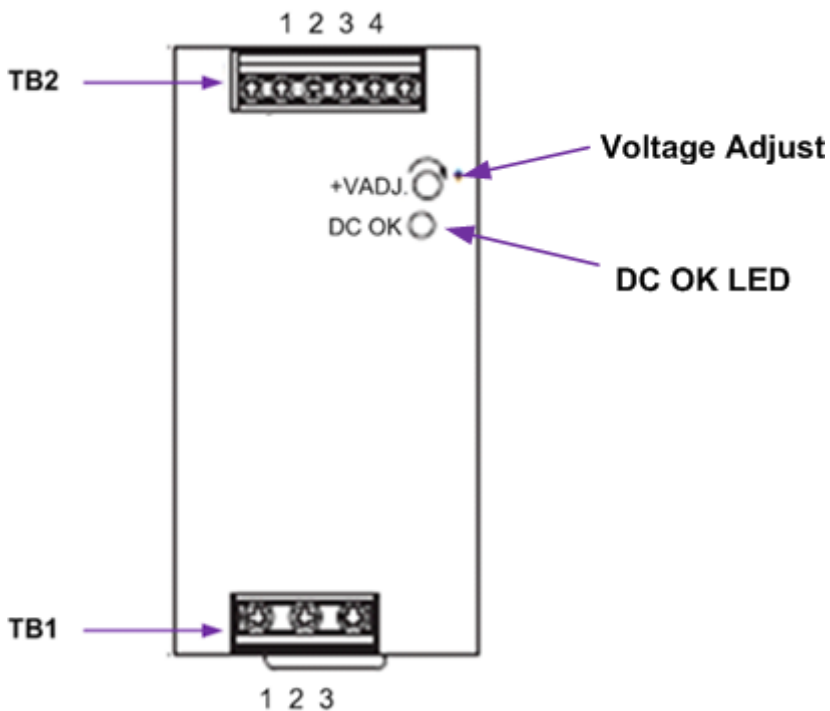

## LED Descriptions

The front panel LEDs provide switch status checking and monitoring. The three types of LEDs are:

- **PWR (Power) LEDs** indicate if the switch is powered up correctly.
- **SYS (System) LED** indicates if the system is ready.
- **Port Status LEDs** indicate the current status of each port.

The front panel **SYS** and **PWR** LEDs are shown and described below. See the PD device manual for its LED descriptions.

### System and Power LEDs

LED	Color	State	Description
<b>SYS</b> (System)	Green	On Off	The switch is ready. The switch is not ready.
<b>PWR2</b>	Green	On Off	The switch is powered on correctly. The switch is not receiving power from Power 2 (P2).
<b>PWR1</b>	Green	On Off	The switch is powered on correctly. The switch is not receiving power from Power 1 (P1).



The front panel port status LEDs are described below.

LED	Color	State	Description
RJ45 Ports (Left Side)	Green	On	The port is enabled and established a link to connected device, and the connection speed is 1000Mbps.
	Green	Blinking	The port is transmitting/receiving packets, and the connection speed is 1000Mbps.
	Amber	On	The port is enabled and established a link to connected device, and the connection speed is 10/100Mbps.
	Amber	Blinking	The port is transmitting/receiving packets, and the connection speed is 10/100Mbps.
	--	Off	The port has no active network cable connected, or it is not established a link to connected device.
RJ45 Ports (Right Side)	Green	On	The port is enabled and supplying power to connected device.
	Green	Blinking	An abnormal state, such as overload status, has been detected in the switch.
	--	Off	The port has no active network cable connected, or it is not connected a PoE PD device.
SFP Ports	Green	On	The port is enabled and established a link to connected device, and the connection speed is 1000Mbps.
	Green	Blinking	The port is transmitting/receiving packets, and the connection speed is 1000Mbps.
	Amber	On	The port is enabled and established a link to connected device, and the connection speed is 100Mbps.
	Amber	Blinking	The port is transmitting/receiving packets, and the connection speed is 100Mbps.
	--	Off	The port has no active network cable connected, or it is not established a link to connected device.

## Troubleshooting

### General Troubleshooting

1. Make sure your switch model supports the feature or function attempted; see [Specifications](#) on page 6.
2. Check if the correct power cord is connected firmly to the switch and to the DC outlet socket.
3. Verify the Fiber and Ethernet cabling; see [Installation and Setup](#) on page 12.
4. Verify the install process; see [Installation and Setup](#) on page 12.
5. Make sure the connected devices are up and running correctly to isolate the problem to the switch.
6. Press the **RESET** button; see the “[Back and Bottom Panels](#)” description on page 10.
7. Power cycle the switch.

### LED Summary

	LED	Color	Function
Global	<b>SYS</b> (System)	Green	SYS LED: Green single color: Off: All Power Off On: Switch FW Boot Complete Blinking: System Booting
Global	<b>P1</b> (Input Power 1)	Green	Power 1 LED: Green single color: Off: Power 1 Off On: Power 1 On
Global	<b>P2</b> (Input Power 2)	Green	Power 2 LED: Green single color: Off: Power 2 Off. On: Power 2 On.
TP (RJ45) Ports 1-8	PoE	Green/ Amber	PoE on TP green/amber bi-color: Off : PoE is Off. Green On: PoE is On. Amber On: PoE Abnormal.
TP (RJ45) Ports 1-8	Link/Act/Speed	Green/ Amber	PoE - TP green/amber bi-color: Green On when device connected 1000Mbps. Amber On when device connected 100M. Amber On when device connected 10M. LEDs blinking when port is sending or receiving data PoE behavior: LED Off: PoE is Off. Green LED lit: PoE is On. Amber LED lit: PoE is abnormal.
SFP Ports 9-10	Link/Act/Speed	Green/ Amber	LNK: green/amber bi-color: LED Off: Port disconnected or Link failed. Green On when device connected 1000Mbps. Amber On when device connected 100M. LEDs blinking when port is sending or receiving data.

## LED Troubleshooting

Symptom	Possible Cause	Suggested Solution
System LED is Off	The switch is not receiving power.	<ol style="list-style-type: none"> <li>1. Check if correct power cord is connected firmly to the switch and to the DC outlet socket.</li> <li>2. Perform power cycling the switch by unplugging and plugging the power cord back into the switch.</li> <li>3. If the LED is still off, try to plug the power cord into a different DC outlet socket to make sure correct DC source is supplied.</li> </ol>
Port (Left Side) Status LED is Off	The port is not connected or the connection is not working.	<ol style="list-style-type: none"> <li>1. Check if the cable connector plug is firmly inserted and locked into the port at both the switch and the connected device.</li> <li>2. Make sure the connected device is up and running correctly.</li> <li>3. If the symptom still exists, try different cable or different port, in order to identify if it is related to the cable or specific port.</li> </ol>
Port (Right Side) Status LED is Off	The port is not supplying power.	<ol style="list-style-type: none"> <li>1. Check if the cable connector plug is firmly inserted and locked into the port at both the switch and the connected device.</li> <li>2. Make sure the correct Ethernet cables are used.</li> <li>3. If the symptom still exists, try different cable or different port, in order to identify if it is related to the cable or specific port.</li> </ol>

## PoE Modes and Compliance

### PoE Deployment Environments A and B

IEEE802.3at-2009 defines two deployment environments in section 33.4.1:

**Environment A:** when both PSE and PD are located indoors, inside the same building. In this environment, there must be electrical isolation between the PoE circuitry and the data circuitry inside a PSE. Multi-port PSE's can all share the same ground isolation. Environment A is therefore an indoor PSE –indoor PD environment (a.k.a. indoor/indoor).

**Environment B:** when the PSE and PD are not located in the same building. In this environment there needs to be electrical isolation between PoE and data, as well as between every port in a multi-port PSE. This isolation between ports requirement de facto determines a completely separate power supply per port, which makes multi-port PSE's for outdoor PD deployment impractical. Environment B is therefore an indoor PSE-outdoor PD (a.k.a. indoor/outdoor) or outdoor PSE-outdoor PD (a.k.a. outdoor/outdoor) environment.

This means only single-port PSE's should normally be used when PD's are deployed outdoors. In summary, the PD-PSE environment is one of these three combinations:

1. PoE Source is indoor; PD is indoor (Env. A)
2. PoE Source is indoor; PD is outdoor (Env. B)
3. PoE Source is outdoor; PD is outdoor (Env. B)

Option 3 is the most challenging environment since both the PD and PSE are installed outdoors.

**Caution:** The switch is an indoor device. If it is to be used with outdoor devices such as outdoor IP cameras or outdoor Wi-Fi APs, then you are strongly suggested to install a surge protector or surge suppressor in order to protect the switch. The switch is compliant with 802.3at in Environment A when using an isolated power supply. For 802.3at Environment B applications, i.e. building to building, copper to copper endpoint connections: 1) use an Ethernet network isolator module (PoE disabled), or 2) use mid-span injector (s), e.g. MIL-L100i, L1000i-at, between this switch's PSE port and link partner PD port.

### Mode A vs. Mode B

Alternative A, also known as Mode A, uses the data pairs of an Ethernet link to deliver power. Data Pairs include pins 1,2 and 3,6. PSEs using Mode A supply a positive voltage to pins 1 and 2.

Alternative B, also known as Mode B, uses the spare pairs to deliver power. Spare Pairs include pins 4,5 and 7,8.

### 802.3af/at Standard "compliant" vs "compatible" PDs

Knowing the difference between PoE "compliant" and "compatible" devices can help avoid interoperability and connectivity issues. Compliant PoE devices and compatible PoE devices are not held to the same 802.3af/at standard:

- 802.3af/at "compliant" PDs fulfill the IEEE strict requirement to support both Mode A and Mode B power modes.
- 802.3af/at "compatible" PDs typically can provide power using only Mode B.

### Typical PD Power Requirements

- 1.8 Watts: Lantronix' M/GE-ISW-SFP-01-PD (Class 1 Powered Device (0.44 Watts - 3.84 Watts)).
- 13W: IP Camera, VoIP Phone, Wireless Access Point, Networked Audio.
- 30W: IP Telephone, WiMAX Access Point, PTZ Camera, Remote Computer Terminal.
- 60W : Door Access System, Video Phone, Thin Client.
- 100W: Digital Signage Display, Point-of-Sale System, LCD TV, Computer Monitor.
- 200W: Larger TV, Larger Display, Larger Monitor, Laptop.

After eliminating basic network factors, ask your PD vendor for the PD's power supply mode and polarities supported and exact power consumption.

### Calculate PoE Power Budget

To calculate how many 802.3at devices the unit supports, divide the Total PoE Budget (130 Watts) by 30 Watts.

To calculate the maximum number of 802.3af devices, divide the Total PoE Budget (130 Watts) by 15.4 Watts.

### Mixing POE and Non-POE Devices

You can mix POE and non-POE devices on the same POE switch (i.e., you can put PCs on the same PoE switch as a SIP phone or a VOIP phone). The PSE (your switch) will only send power if requested by the PD.



### Ethernet and PoE Intra-Building Cabling Warnings

1. Ethernet cables are intended for intrabuilding use only. Connecting your Lantronix switch directly to Ethernet cables that run outside the building in which the switch is housed will void the user's warranty and could create a fire or shock hazard.
2. PoE cables are intended for intrabuilding use only. Connecting your Lantronix switch directly to PoE cables that run outside the building in which the switch is housed will void the user's warranty and could create a fire or shock hazard.
3. For outdoor PoE applications, we recommend using Lantronix' SI-IES-1200-LRT Unmanaged Hardened PoE+ Injector or SI-IES-111D-LRT Unmanaged Hardened PoE+ Injector/Converter Use of any other PoE injector will void the user's warranty and could create a fire or shock hazard.

### Legacy PD Detection / Capacitor Detection

Legacy PDs refers to powered devices manufactured before the IEEE standard was finalized and do not have the expected PD signature required by the PSE's detection signal. Such PDs usually feature large capacitance as the detection signature that does not completely comply with the 802.3af specs. By enabling this option, the switch will probe for legacy PDs and if a legacy PD is detected, the switch will provide power to the PD.

### Troubleshooting PoE Problems

1. Get as much detail as possible regarding the symptom, including any system messages from the PoE switch. For example, does a PD not power up at all, or does it power up briefly and then power down?
2. Determine if the trouble occurred on initial installation or after the PD had been working normally.
3. If the trouble started after the PD was working, what changed? Did hardware or software change?
4. Verify that the port is not shut down, disabled, or errored.
5. Verify that the Ethernet cable from the PD to the switch port is good.
6. Verify that the total cable length from the switch front panel to the connected PD is not more than 100 meters. Some of the power from the switch port is dissipated in the cable due to wire resistance, especially on cables as long as 100 meters. Only the remaining power is available to the PD. The 100-meter limit for twisted-pair Ethernet cable assumes **a)** not more than four RJ-45 connection points in the transmission path, **b)** 90 meters of solid-strand Category 5 or 5e, and **c)** 10 meters of flexible multistrand cable (2-to-5 meters of multistrand Category 5 patch cords).
7. Verify that the PSE switch power budget can power the PD. If the switch power budget is depleted, additional PDs will not power-on when connected to a PoE port. Verify that the switch power budget (available PoE) is not depleted before or after the PD is connected. Verify that sufficient power is available for the PD type.
8. Verify if non-powered Ethernet devices can establish an Ethernet link on any port and that PoE devices do not power up on the same port.
9. Review alarms reported previously by system messages.
10. If a working IP Phone or WAP intermittently reloads or disconnects from inline power, verify all electrical connections from the switch to the PD. An unreliable connection results in power interruptions and intermittent PD operation, such as PD disconnects and reloads.
11. Check for changes in the electrical environment at the switch site. What is happening at the PD when the disconnect occurs? Check for error messages reported by the switch at the same time of the disconnect.
12. Verify that an IP Phone is not losing access just before a reload occurs (a network problem, not a PoE problem).

13. Pre-standard and post-standard VoIP phones may use different detection and connect / disconnect methods. Note that PD detection occurs when an Ethernet device is first connected to a PoE port. If a non-PoE device is connected to a PoE port, detection is deactivated. If the non-PoE device is later disconnected and replaced by a PD, the switch may not detect it immediately.
14. Verify that the PD is not causing an overcurrent condition on the port. Specifically: does the VoIP phone initially power on and then disconnect? If so, the problem may be an initial current surge that exceeds a current-limit threshold for the switch port. Some PDs may have excessive “surge in” current when first connected to a PoE port. The switch initially provides power to the port, and then quickly removes power due to a momentary overcurrent condition. The PD starts to power up, but then quickly powers down.
15. Most PoE switches have voltage and current regulators that detect an overcurrent threshold and disconnect power from the line. This prevents excessive current from being delivered by the PoE port, which could possibly result in damage to port-level components.
16. A variety of disturbances on the AC power line (mains) can cause odd PoE problems. The power supplies in various switches and PDs can react uniquely to AC input disturbances. AC disruption problems are usually temporary or one-time occurrences. For example, a specific switch or PD may reboot due to an AC power problem, while other switches or PDs may show a greater immunity to the problem. This is a typical occurrence during lightning storms or AC power maintenance. In a worst-case scenario, a PoE power supply may appear to shut down, with no PoE output voltage to any port. It’s possible the switch’s Ethernet functions appear normal, and only the PoE functions are disrupted or degraded, or the switch may power down completely due to the AC disturbance. PDs may exhibit unusual behavior. In such cases, power cycle the switch (unplug the switch, wait at least three seconds, then plug it back in. This will ensure a total system reset that should restore normal operation.
17. Check if related features (LLDP mode, CDP mode) are enabled. See our [PoE Brochure](#) for more information.

## Declaration of Conformity

### Declaration of Conformity

**Manufacturer's Name:** Lantronix, Inc.

**Manufacturer's Address:** 7535 Irvine Center Drive, Suite100, Irvine, CA 92618, USA

**Declares that the products:**

SISTP1010-360-LRT, SISTP1010-380-LRT-C, SISTP1040-342-LRT, SISTP1040-382-LRT,  
SISTG1040-242-LRT, SISTG1040-282-LRT

**Conform to the following Product Regulations:**

FCC Part 15 Class A, EN 55032:2012, EN 55024:2010 Directive 2014/30/EU, Directive 2015/863/EU  
Low-Voltage Directive 2014/35/EU IEC 62368-1:2014 (Second Edition); and/or EN 62368-1:2014/A11:2017;  
and/or BS EN 62368-1:2014+A11:2017. 2011/65/EU EN 50581:2012  
EN 61000-3-2:2014, Class A. EN 61000-3-3:2013. EN 55024:2010. EN 61000-4-2:2009 / IEC 61000-4-2:2008 ED. 2.0.  
EN 61000-4-3:2006 +A1:2008 +A2:2010 / IEC 61000-4-3:2010 ED. 3.2.  
EN 61000-4-4:2012 / IEC 61000-4-4:2012 ED. 3.0. EN 61000-4-5:2006 / IEC 61000-4-5:2005 ED. 3.0.  
EN 61000-4-6:2014 / IEC 61000-4-6:2013 ED. 4.0. EN 61000-4-8:2010 / IEC 61000-4-8:2009 ED 2.0.  
EN 61000-4-11:2004 / IEC 61000-4-11:2004 ED 2.0. Australian Standard AS/NZS CISPR 22:2009/A1:2010 Class A.  
Standard(s) for Safety: UL 121201 Nonincendive Electrical Equipment for Use in  
Class I and II, Division 2 and Class III, Divisions 1 and 2 Hazardous (Classified) Locations,  
CSA C22.2 NO. 213 Nonincendive Electrical Equipment for Use in Class I and II,  
Division 2 and Class III, Divisions 1 and 2 Hazardous (Classified) Locations  
With the technical construction on file at the above address, this product carries the **CE Mark**

I, the undersigned, hereby declare that the equipment specified above conforms to the above Directive(s) and Standard(s).

Place: Minnetonka, Minnesota

Date: July 28,2021

Signature: Fathi Hakam

Full Name: Fathi Hakam Position: Vice President of Engineering

## User Information

**Caution:** changes or modifications not expressly approved by the party responsible for compliance could void the user's authority to operate the equipment.

This equipment has been tested and found to comply with the limits for a Class A device, pursuant to part 15 of the FCC Rules. These limits are designed to provide reasonable protection against harmful interference when equipment is operated in a commercial environment. This equipment generates, uses, and can radiate radio frequency energy and, if not installed and used in accordance with the instruction manual, may cause harmful interference to radio communications. Operation of this equipment in a residential area is likely to cause harmful interference in which case the user will be required to correct the interference at his own expense.

Test Standard: 47 CFR FCC Rules and Regulations Part 15 Subpart B, Class A Digital Device. ICES-003 Issue 6, Class A. The energy emitted by this equipment was passed CISPR PUB. 22 and FCC Part 15 Subpart B and Canada Standard ICES-003 Issue 6.

These devices are open-type devices that are to be installed in an enclosure only accessible with the use of a tool, suitable for the environment.

This equipment is suitable for use in Class I, Division 2, Groups A, B, C, and D or non-hazardous locations only.  
"WARNING – EXPLOSION HAZARD. DO NOT DISCONNECT WHILE THE CIRCUIT IS LIVE OR UNLESS THE AREA IS FREE OF IGNITIBLE CONCENTRATIONS.

Temperature code (T-Code) – T4.

## Cautions and Warnings

### Definitions

Cautions indicate that there is the possibility of poor equipment performance or potential damage to the equipment.

Warnings indicate that there is the possibility of injury to person.

Cautions and Warnings appear here and may appear throughout this manual where appropriate. Failure to read and understand the information identified by this symbol could result in poor equipment performance, damage to the equipment, or injury to persons.



### Cautions

**Do not** ship or store devices near strong electrostatic, electromagnetic, magnetic, or radioactive fields.

**Caution:** When handling chassis devices observe electrostatic discharge precautions. This requires proper grounding (i.e., wear a wrist strap).

**Caution:** Copper based media ports, e.g., Twisted Pair (TP) Ethernet, USB, RS232, RS422, RS485, DS1, DS3, Video Coax, etc., are intended to be connected to intra-building (*inside plant*) link segments that are not subject to lightning transients or power faults. They are **not** to be connected to inter-building (*outside plant*) link segments that are subject to lightning.

**Caution:** **Do not** install the device in areas where strong electromagnetic fields (EMF) exist. Failure to observe this caution could result in poor device performance.

**Caution:** Read the installation instructions before connecting the chassis to a power source. Failure to observe this caution could result in poor performance or damage to the equipment.

**Caution:** Only trained and qualified personnel should install or perform maintenance on the device. Failure to observe this caution could result in poor performance or damage to the equipment.

**Caution:** Do not let optical fibers come into physical contact with any bare part of the body since they are fragile, and difficult to detect and remove from the body.

**Caution:** Do not bend any part of an optical fiber/cable to a diameter that is smaller than the minimum permitted according to the manufacturer's specification (usually about 65 mm or 2.5 in)!



### Warnings

**Warning:** Use of controls, adjustments or the performance of procedures other than those specified herein may result in hazardous radiation exposure.

**Warning:** Visible and invisible laser radiation when open. **Do not** stare into the beam or view the beam directly with optical instruments. Failure to observe this warning could result in an eye injury or blindness.

**Warning:** DO NOT connect the power supply module to external power before installing it into the chassis. Failure to observe this warning could result in an electrical shock or death.

**Warning:** Select mounting bracket locations on the chassis that will keep the chassis balanced when mounted in the rack. Failure to observe this warning could allow the chassis to fall, resulting in equipment damage and/or possible injury to persons.

**Warning:** Do not work on the chassis, connect, or disconnect cables during a storm with lightning. Failure to observe this warning could result in an electrical shock or death.

**High Risk Activities Disclaimer:** Components, units, or third-party products used in the product described herein are NOT fault-tolerant and are NOT designed, manufactured, or intended for use as on-line control equipment in the following hazardous environments requiring fail-safe controls: the operation of Nuclear Facilities, Aircraft Navigation or Aircraft Communication Systems, Air Traffic Control, Life Support, or Weapons Systems ("High Risk Activities"). Lantronix and its supplier(s) specifically disclaim any expressed or implied warranty of fitness for such High Risk Activities.

**Warning and Caution - Proper Installation and Operation (English)**

These devices are open-type devices that are to be installed in an enclosure only accessible with the use of a tool, suitable for the environment. This equipment is suitable for use in Class I, Division 2, Groups A, B, C, and D or non-hazardous locations only. **WARNING – EXPLOSION HAZARD. DO NOT DISCONNECT WHILE THE CIRCUIT IS LIVE OR UNLESS THE AREA IS FREE OF IGNITIBLE CONCENTRATIONS.**

**Avertissement et mise en garde - Installation et fonctionnement corrects (français)**

Ces périphériques sont des périphériques de type ouvert qui doivent être installés dans un enceinte uniquement accessible à l'aide d'un outil, adapté à l'environnement. Cet équipement peut être utilisé dans la classe I, division 2, groupes A, B, C, et D ou des emplacements non dangereux seulement. **AVERTISSEMENT - RISQUE D'EXPLOSION. NE PAS SE DÉCONNECTER LORSQUE LE CIRCUIT EST VIVANT OU À MOINS QUE LA ZONE NE SOIT LIBRE DE CONCENTRATIONS IGNIFIABLES.**

**Electrical Safety Warnings****Electrical Safety**

**IMPORTANT:** This equipment must be installed in accordance with safety precautions.

**Elektrische Sicherheit**

**WICHTIG:** Für die Installation dieses Gerätes ist die Einhaltung von Sicherheitsvorkehrungen erforderlich.

**Elektrisk sikkerhed**

**VIGTIGT:** Dette udstyr skal installeres i overensstemmelse med sikkerhedsadvarslerne.

**Elektrische veiligheid**

**BELANGRIJK:** Dit apparaat moet in overeenstemming met de veiligheidsvoorschriften worden geïnstalleerd.

**Sécurité électrique**

**IMPORTANT :** Cet équipement doit être utilisé conformément aux instructions de sécurité.

**Sähköturvallisuus**

**TÄRKEÄÄ :** Tämä laite on asennettava turvaohjeiden mukaisesti.

**Sicurezza elettrica**

**IMPORTANTE:** questa apparecchiatura deve essere installata rispettando le norme di sicurezza.

**Elektrisk sikkerhet**

**VIKTIG:** Dette utstyret skal installeres i samsvar med sikkerhetsregler.

**Segurança eléctrica**

**IMPORTANTE:** Este equipamento tem que ser instalado segundo as medidas de precaução de segurança.

**Seguridad eléctrica**

**IMPORTANTE:** La instalación de este equipo deberá llevarse a cabo cumpliendo con las precauciones de seguridad.

**Elsäkerhet**

**OBS!** Alla nödvändiga försiktighetsåtgärder måste vidtas när denna utrustning används.

**Note:** The MODEL number, Part Number (P/N), and Serial Number (S/N) are printed on the shipping box and on the bottom of the Switch.

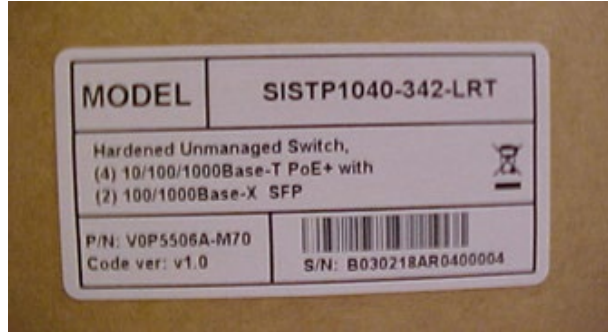

### Recording Model Information and System Information

After performing the troubleshooting procedures, and before calling or emailing Technical Support, please record as much information as possible to help the Tech Support Specialist.

1. Record the **Model Information** for your system.

Serial Number: \_\_\_\_\_ Model: \_\_\_\_\_  
 Software Revision: \_\_\_\_\_ Hardware Revision: \_\_\_\_\_  
 Number of Ports: \_\_\_\_\_ Power Supply used: \_\_\_\_\_

2. Provide additional Model and System information to your Technical Support Specialist.

Your Lantronix service contract number: \_\_\_\_\_

A description of the failure: \_\_\_\_\_

LED Status: \_\_\_\_\_

Describe any action(s) already taken to resolve the problem (e.g., changing switch mode, rebooting, etc.):

\_\_\_\_\_  
 \_\_\_\_\_

The serial and revision numbers of all involved Lantronix products in the network:

\_\_\_\_\_

A description of your network environment (layout, cable type, PoE / PoE+, PD, etc.):

\_\_\_\_\_  
 \_\_\_\_\_

Network load and frame size at the time of trouble (if known): \_\_\_\_\_

The device history (i.e., have you returned the device before, is this a recurring problem, etc.):

\_\_\_\_\_

Any previous Return Material Authorization (RMA) numbers: \_\_\_\_\_

**Lantronix Corporate Headquarters**

7535 Irvine Center Drive  
Suite100  
Irvine, CA 92618, USA  
Toll Free: 800-526-8766  
Phone: 949-453-3990  
Fax: 949-453-3995

**Technical Support**

Online: <https://www.lantronix.com/technical-support/>

**Sales Offices**

For a current list of our domestic and international sales offices, go to the Lantronix web site at [www.lantronix.com/about/contact](http://www.lantronix.com/about/contact).