



## SM8TAT2SA, SM16TAT2SA, *and* SM24TAT2SA

Smart Managed Switches, 8-/16-/24-Port Gigabit PoE+,  
2-Port 100/1000 SFP Slots

## Install Guide

**Part Number 33716**  
**Revision L June 2022**

## Intellectual Property

© 2022 Lantronix, Inc. All rights reserved. No part of the contents of this publication may be transmitted or reproduced in any form or by any means without the written permission of Lantronix.

*Lantronix* is a registered trademark of Lantronix, Inc. in the United States and other countries. All other trademarks and trade names are the property of their respective holders.

Patented: <https://www.lantronix.com/legal/patents/>; additional patents pending.

## Warranty

For details on the Lantronix warranty policy, go to <http://www.lantronix.com/support/warranty>.

## Contacts

### Lantronix Corporate Headquarters

7535 Irvine Center Drive  
Suite100  
Irvine, CA 92618, USA  
Toll Free: 800-526-8766  
Phone: 949-453-3990  
Fax: 949-453-3995

### Technical Support

Phone: +1.952.358.3601 or 1.800.260.1312; Email: <https://www.lantronix.com/technical-support/>

### Sales Offices

For a current list of our domestic and international sales offices, go to [www.lantronix.com/about/contact](http://www.lantronix.com/about/contact).

## Disclaimer

All information contained herein is provided "AS IS." Lantronix undertakes no obligation to update the information in this publication. Lantronix does not make, and specifically disclaims, all warranties of any kind (express, implied or otherwise) regarding title, non-infringement, fitness, quality, accuracy, completeness, usefulness, suitability or performance of the information provided herein. Lantronix shall have no liability whatsoever to any user for any damages, losses and causes of action (whether in contract or in tort or otherwise) in connection with the user's access or usage of any of the information or content contained herein. The information and specifications contained in this document are subject to change without notice.

## Revision History

Date	Rev	Description
7/28/21	J	FW v1.04.0020: Add PING and Traceroute API commands and add API support for "copy startup-config to running-config" in replace mode. Fix first time wizard DNS field, add time zone in syslog time format, add Always-On PoE in mib, add 5 API commands and fix 8 API commands. Fix LLDP neighbor management address issue and PoE Mode field issue after IP camera reboot. Update Safety certification from EN60950/IEC60950 to IEC62368-1/EN62368-1.
2/23/22	K	FW v1.04.0041; fixed misc. bugs (please see Release Notes); initial Lantronix rebrand.
6/20/22	L	Update labels and contact information.

## Cautions and Warnings

**Cautions** indicate that there is the possibility of poor equipment performance or potential damage to the equipment.

**Warnings** indicate that there is the possibility of injury to person.

Cautions and Warnings appear here and may appear throughout this manual where appropriate. Failure to read and understand the information identified by this symbol could result in poor equipment performance, damage to the equipment, or injury to persons.



**Caution:** While installing or servicing the power supply module, wear a grounding device and observe all electrostatic discharge precautions. Failure to observe this caution could result in damage to, or failure of the power module.



**Warning:** Do not connect the power module to an external power source before installing it into the chassis. Failure to observe this warning could result in an electrical shock, even death.

**Warning:** Equipment grounding is vital to ensure safe operation. The installer must ensure that the power module is properly grounded during and after installation. Failure to observe this warning could result in an electric shock, even death.

**Warning:** A readily accessible, suitable National Electrical Code (NEC) or local electrical code approved disconnect device and branch-circuit protector must be part of the building's installed wiring to accommodate permanently connected equipment. Failure to observe this warning could result in an electric shock, even death.

**Warning:** Turn any external power source OFF and ensure that the power module is disconnected from the external power source before performing any maintenance. Failure to observe this warning could result in an electrical shock, even death.

**Warning:** Ensure that the disconnect device for the external power source is OPEN (*turned OFF*) before disconnecting or connecting the power leads to the power module. Failure to observe this warning could result in an electric shock, even death.

See [Electrical Safety Warnings](#) on page 29 for electrical safety warnings translated into multiple languages.

## Contents

<b>Chapter 1 Introduction</b> .....	<b>5</b>
Key Features .....	5
Benefits.....	5
Ordering Information.....	6
Specifications.....	6
Software Features .....	8
About This Manual.....	10
Related Manuals.....	10
<b>Chapter 2 Introduction and Product Description</b> .....	<b>11</b>
Overview.....	11
Front and Back Panels .....	11
LED Descriptions .....	13
System LED.....	13
Mode LEDs .....	13
Port Status LEDs .....	13
Mode/Reset Button .....	15
<b>Chapter 3 Installation</b> .....	<b>16</b>
Package Contents .....	16
Mounting the Switch on a Wall .....	16
Mounting the Switch on Desk or Shelf.....	17
Mounting the Switch in a 19-inch Rack .....	17
Installing SFP Modules.....	18
Connecting Devices.....	18
Connecting the AC Power Cord .....	19
<b>Chapter 4 Initial Switch Configuration</b> .....	<b>20</b>
Initial Switch Configuration via Web Browser.....	20
Initial Switch Configuration via CLI .....	21
<b>Chapter 5 Troubleshooting, Support, and Compliance</b> .....	<b>22</b>
Troubleshooting .....	22
PoE Modes and Compliance .....	23
Troubleshooting PoE Problems.....	24
Recording Device and System Information .....	26
Compliance Information.....	27

## Chapter 1 Introduction

The SMxTAT2SA Smart Managed GbE PoE+ switch is the next-generation Ethernet switch offering powerful L2 features with better functionality and usability. It delivers cost-effective business and transport Ethernet services via fiber or copper connections.

The SMxTAT2SA delivers 8/16/24 (10M/100M/1G) RJ45 ports with 8 PoE+ ports (supports 802.3 at/af and total up to 130W on the SM8TAT2SA) and 2 GbE SFP ports. The SMxTAT2SA provides high hardware performance and environment flexibility for SMBs and Enterprises.

The embedded Device Managed System (DMS) feature makes the switch easy to use, configure, install, and troubleshoot in the video surveillance, wireless access, and other SMBs and Enterprises applications. The SMxTAT2SA delivers management simplicity, better user experience, and lowest total cost of ownership.

### Key Features

- ‘Smart managed’ features provide easier manageability, basic security, and QoS
- Built in Device Management System (DMS); Graphical Monitoring, Traffic Monitoring, Troubleshooting
- DHCP Server, DHCP statistics, DHCP relay option 82, DHCP relay statistic
- PoE Port configuration and scheduling
- IEEE 802.3af/at Power over Ethernet (PoE); Auto Power Reset and Always on PoE
- IEEE 802.3az EEE Energy Efficient Ethernet standard for Green Ethernet
- Support Jumbo Frame up to 9K bytes
- RADIUS, TACACS+ Authentication
- LLDP (Link Layer Discovery Protocol)

### Benefits

**Cost-effective Ethernet Switch for Enterprise-class:** The switch delivers advanced functionality in a smart managed switch including DHCP client, IGMP, LLDP, etc. It has security features such as IEEE 802.1x to protect your network from unauthorized access. It helps you build on the switch’s market-leading price/performance and provides ease of use for enterprise and SMB deployments.

**Easy to Install, Configure and Troubleshoot via DMS:** The Device Management System (DMS) provides embedded functions to facilitate devices management at anytime and anywhere. Its user-friendly interface helps you manage devices intuitively. It supports various IP device types (e.g., PC, IP-phone, IP-camera, WAP) to enhance manageability and save time/cost during installation/maintenance stages.

**Lower TCO with EEE Design:** The switch is designed to help companies save power and reduce TCO (Total Cost of Ownership) by Energy Efficient Ethernet (IEEE 802.3az). It can be used to build a green Ethernet networking environment.

**Advanced Power over Ethernet Management:** The model includes PoE+ options to power IP devices with power-saving features like Power scheduling and PoE configuration.

## Ordering Information

This manual documents three similar models as described below. The models differ mainly in port count. Model differences are noted where applicable throughout this manual.

Model	Description
<b>SM8TAT2SA</b>	Smart Managed PoE+ layer 2 Switch with 20Gbps switching capacity and Smart management (Web GUI, SNMP, Telnet, CLI); PoE scheduling, APR, and DMS feature support. Port support description: Eight 10/100/1000Base-T + two 100/1000 SFP Slots. Includes 19" rack mount brackets and country specific power cord.
<b>SM16TAT2SA</b>	Smart Managed PoE+ layer 2 Switch with 36Gbps switching capacity and Smart management (Web GUI, SNMP, Telnet, CLI); PoE scheduling, APR, and DMS feature support. Port support description: Sixteen 10/100/1000Base-T + two 100/1000 SFP Slots. Includes 19" rack mount brackets and country specific power cord.
<b>SM24TAT2SA</b>	Smart Managed PoE+ layer 2 Switch with 52Gbps switching capacity and Smart management (Web GUI, SNMP, Telnet, CLI); PoE scheduling, APR, and DMS feature support. Port support description: Twenty-four 10/100/1000Base-T + two 100/1000 SFP Slots. Includes 19" rack mount brackets and country specific power cord.

## Specifications

### Port Configuration

Total Ports	RJ45 (10M/100M/1G)	Uplinks (100M/1G)	Telnet
SM8TAT2SA = 10	8	2 SFP	Via any RJ45 port
SM16TAT2SA = 18	16	2 SFP	Via any RJ45 port
SM24TAT2SA = 26	24	2 SFP	Via any RJ45 port

### Hardware Performance

Model	Forwarding Capacity (Mbps)	Switching Capacity (Gbps)	Mac Table (K)	Jumbo Frames (Bytes)
SM8TAT2SA	14.88	20	8	9216
SM16TAT2SA	26.784	36	8	9216
SM24TAT2SA	38.688	52	8	9216

### Environmental Range

Operating Temperature		Storage Temperature		Operating Humidity	Altitude	
Fahrenheit	Centigrade	Fahrenheit	Centigrade		Feet	Meters
32 to 122°	0 to 50°	-4 to 158°	-20 to 70°	10% to 90% non-condensing	< 10000	<3000

## Dimensions, Weights, Mounting

Model	Dimensions (WxHxD)		Weight		Mounting Type
	Millimeters	Inches	Kilograms	Pounds	
SM8TAT2SA	220 x 44 x 242	8.6 x 1.7 x 9.5	2.0	4.4	Desktop, Wall, Rack
SM16TAT2SA	442x 44x 211	17.4x 1.7x 8.3	3.0	6.6	Desktop, Wall, Rack
SM24TAT2SA	442x 44x 211	17.4x 1.7x 8.3	3.0	6.6	Desktop, Wall, Rack

## Voltage and Frequency

AC Input Voltage and Frequency	
Voltage	100-240 VAC
Frequency	50~60 Hz
Surge Suppression	6KV before FW v 1.02.1409 802.3at PoE isolation and online Surge protection 1KV at FW v 1.02.1409

## PoE Power

Model	PoE Support
SM8TAT2SA	Max PoE budget 130 Watts; 30 Watts for (4) ports simultaneously; 15.4 Watts for (8) ports simultaneously. Each of ports 1 – 8 support PoE/ PoE+ within available PoE Power.
SM16TAT2SA	Max PoE budget 250 Watts; 30 Watts for (8) ports simultaneously; 15.4 Watts for (16) ports simultaneously. Each of ports 1 - 16 support PoE/ PoE+ within available PoE Power.
SM24TAT2SA	Max PoE budget 370 Watts; 30 Watts for (12) ports simultaneously; 15.4 Watts for (24) ports simultaneously. Each of ports 1 - 24 support PoE/ PoE+ within available PoE Power.

## Power Consumption

Power Consumption	Without PoE	Full Load with PoE
SM8TAT2SA	14 Watts	147 Watts
SM16TAT2SA	42 Watts	296 Watts
SM24TAT2SA	45 Watts	438 Watts

## MTBF

SM8TAT2SA	GB, GC - Ground Benign, Controlled 25°C	589,202 Hrs.
	GB, GC - Ground Benign, Controlled 50°C	248,902 Hrs.
SM16TAT2SA	GB, GC - Ground Benign, Controlled 25°C	277,472 Hrs.
	GB, GC - Ground Benign, Controlled 50°C	107,951 Hrs.
SM24TAT2SA	GB, GC - Ground Benign, Controlled 25°C	322,718 Hrs.
	GB, GC - Ground Benign, Controlled 50°C	115,156 Hrs.

## Certifications

Electromagnetic Emissions (EMC) and Safety
EMC: CE, FCC Part 15 Class A Safety: IEC62368-1/EN62368-1, UL Listed EN 55032:2012, EN 55024:2010 Directive 2014/30/EU, Directive 2015/863/EU Low-Voltage Directive 2014/35/EU 2011/65/EU EN 50581:2012 Normas Oficiales Mexicanas (NOM)

## Software Features

Layer 2 Switching	
Spanning Tree Protocol (STP)	<ul style="list-style-type: none"> <li>• Standard Spanning Tree 802.1d</li> <li>• Rapid Spanning Tree (RSTP) 802.1w</li> <li>• Multiple Spanning Tree (MSTP) 802.1s</li> </ul>
Trunking	<ul style="list-style-type: none"> <li>• Link Aggregation Control Protocol (LACP) IEEE 802.3ad</li> <li>• Static aggregation</li> </ul>
VLAN	Supports up to 4K VLANs simultaneously (out of 4096 VLAN IDs). Port-based VLAN; 802.1Q tag-based VLAN; Protocol based VLAN; IP subnet-based VLAN; Private VLAN Edge (PVE); MAC-based VLAN; Q-in-Q (double tag) VLAN; GARP VLAN Registration Protocol (GVRP)
DHCP Relay	<ul style="list-style-type: none"> <li>• Relay of DHCP traffic to DHCP server in different VLAN</li> <li>• Works with DHCP Option 82</li> </ul>
IGMP v1/v2 Snooping	IGMP limits bandwidth-intensive multicast traffic to only the requesters. Supports 1024 multicast groups.
IGMP Querier	IGMP querier is used to support a Layer 2 multicast domain of snooping switches in the absence of a multicast router
IGMP Proxy	IGMP snooping with proxy reporting or report suppression actively filters IGMP packets to reduce load on the multicast router
MLD v1/v2 Snooping	Delivers IPv6 multicast packets only to the required receivers
Multicast VLAN Registration	MVR uses a dedicated manually configured VLAN, called the multicast VLAN, to forward multicast traffic over Layer 2 network in conjunction with IGMP snooping
Security	
Secure Sockets Layer (SSL)	SSL encrypts the http traffic, allowing advanced secure access to the browser-based management GUI in the switch
IEEE 802.1X	<ul style="list-style-type: none"> <li>• IEEE802.1X: RADIUS authentication, authorization and accounting, MD5 hash, guest VLAN, single/multiple host mode and single/multiple sessions</li> <li>• Supports IGMP-RADIUS based 802.1X</li> <li>• Dynamic VLAN assignment</li> </ul>
Layer 2 Isolation Private VLAN Edge	PVE (also known as protected ports) provides L2 isolation between clients in the same VLAN. Supports multiple uplinks
Port Security	Locks MAC addresses to ports and limits the number of learned MAC address



IP Source Guard	Prevents illegal IP address from accessing to specific port in the switch
RADIUS	Supports RADIUS authentication switch as a client
TACACS+	Up to 5 TACACS+ servers are supported
Storm Control	Prevents traffic on a LAN from being disrupted by a broadcast, multicast, or unicast storm on a port
DHCP Snooping	A feature acts as a firewall between untrusted hosts and trusted DHCP servers
Loop Protection	Prevents unknown unicast, broadcast, multicast loops in Layer 2 switching.
<b>Quality of Service (QoS)</b>	
Hardware Queue	Supports 8 hardware queues
Scheduling	<ul style="list-style-type: none"> <li>• Strict priority and weighted round-robin (WRR)</li> <li>• Queue assignment based on DSCP and class of service</li> </ul>
Classification	<ul style="list-style-type: none"> <li>• Port based</li> <li>• 802.1p VLAN priority based</li> </ul>
Rate Limiting	<ul style="list-style-type: none"> <li>• Ingress policer</li> <li>• Egress shaping and rate control</li> <li>• Per port</li> </ul>
<b>Management</b>	
Port Mirroring	Traffic on a port can be mirrored to another port for analysis with a network analyzer or RMON probe. Up to N-1 (N is Switch's Ports) ports can be mirrored to a single destination port. A single session is supported.
IEEE 802.1ab (LLDP)	Used by network devices for advertising their identities, capabilities, and neighbors on an IEEE 802ab local area network. Support LLDP-MED extensions.
Web GUI	Built-in switch configuration utility for browser-based device configuration
Dual Image	Independent primary and secondary images for backup while upgrading
UPnP	The Universal Plug and Play Forum was formed to standardize discovery and control of networked devices. See the Open Connectivity Foundation <a href="#">webpage</a> .
DHCP Server	Support DHCP server to assign IP to DHCP clients
SNMP	SNMP v1, v2c, v3 with traps, and SNMP v 3 user-based security model (USM)
Firmware Upgrade	Web browser upgrade (HTTP/ HTTPs) and TFTP
NTP	Network Time Protocol (NTP) is a networking protocol for clock synchronization between computer systems over packet-switched
Other Management	HTTP/HTTPs; DHCP Client; Cable Diagnostics; Syslog; IPv6 Management, SMTP
<b>Device Management System (DMS)</b>	
Graphical Monitoring	<p>Topology view: Intuitive way to configure and manage switches and other devices with visual relations.</p> <p>Floor view: Easily drag and drop PoE devices and help you to build smart workforces.</p> <p>Map view: Efficiently drag and drop devices and monitor surroundings on Google maps.</p>
Find My Switch	The front panel LEDs flash for 15 seconds to visually identify the switch.

Traffic Monitoring	Display visual chart of network traffic of all devices and monitor every port at any time.
Troubleshooting	Network diagnostic between master switch and devices. Supports protection mechanism, such as rate-limiting to protect your devices from brute-force downloading.
<b>Power over Ethernet (PoE)</b>	
Port Configuration	Supports per port PoE configuration function
PoE Scheduling	Supports per port PoE scheduling to turn on/off the PoE powered devices (PDs).
Auto Power Reset	Automatically checks the link status of PDs, and reboots PDs if there are no responses.
Power Delay	The switch provides power to the PDs based on delay time when PoE switch boots up, to protect switch from misuse of the PDs
Always on PoE	Always On PoE (soft reboot) allows a warm reboot of the switch without affecting the PoE output to the PD, providing continuous power even during firmware upgrade

## About This Manual

This manual describes how to install, configure, and troubleshoot the SMxTAT2SA switch, including how to:

- Install the switch.
- Check switch status by reading the LED behavior.
- Reset the switch or restore the switch to factory defaults.
- Initially configure the switch.
- Troubleshoot switch installation.

## Related Manuals

Related manuals include:

- SMxTAT2SA Quick Start Guide, 33715
- SMxTAT2SA Web User Guide, 33717
- SMxxTATS2A CLI Reference, 33718
- SMxTAT2SA Unified API User Guide, 33825
- Release Notes (version specific)

For Lantronix Drivers, Firmware, Manuals, Product Notifications, Warranty Policy & Procedures, etc. go to the Lantronix [Technical Resource Center](#).

Note that this manual provides links to third party web sites for which Lantronix is not responsible.

## Chapter 2 Introduction and Product Description

### Overview

This section describes the SMxTAT2SA switch, including descriptions of:

- Front and Back Panels.
- Reset the switch or to restore the switch to factory defaults.
- Mode/Reset button operation and functions.

### Front and Back Panels

The front panels are similar except for port counts. The back panels are similar except for overall width.

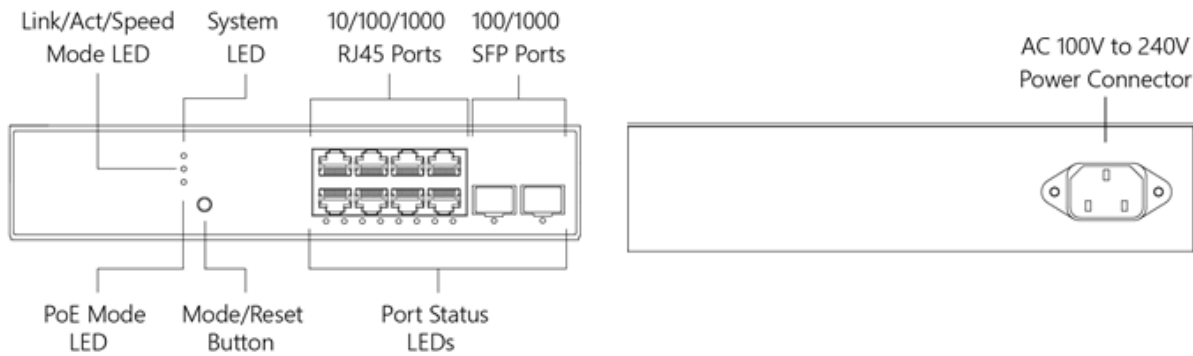

Figure 1: SM8TAT2SA Front and Back Panels

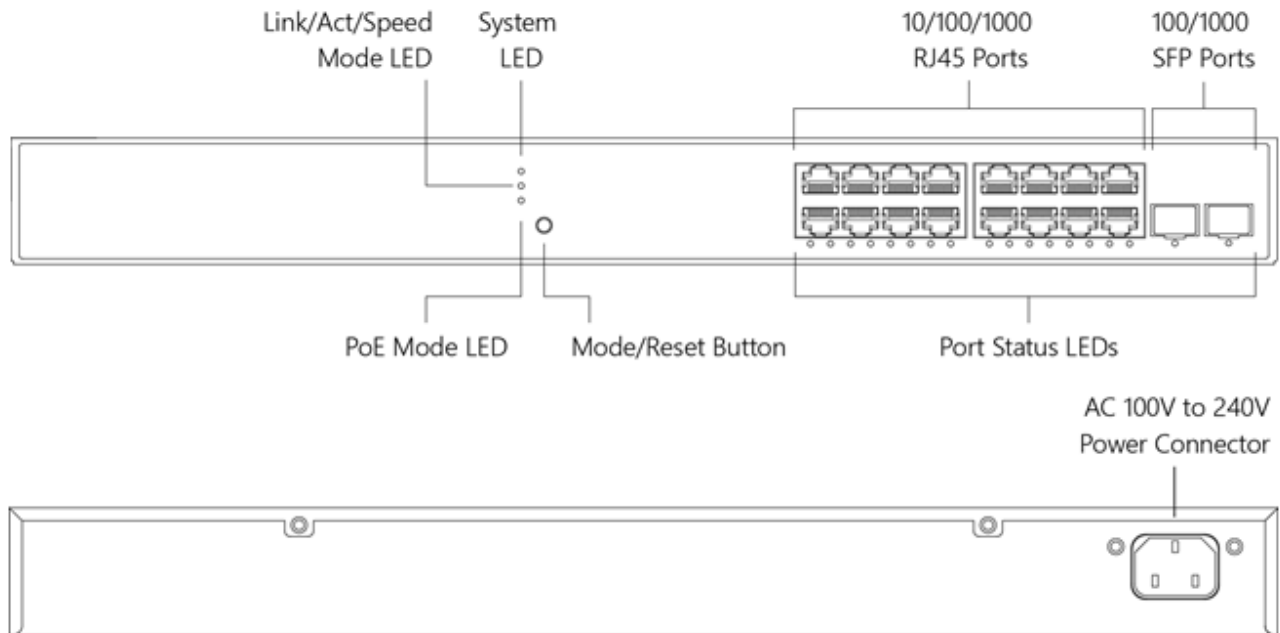

Figure 2: SM16TAT2SA Front and Back Panels

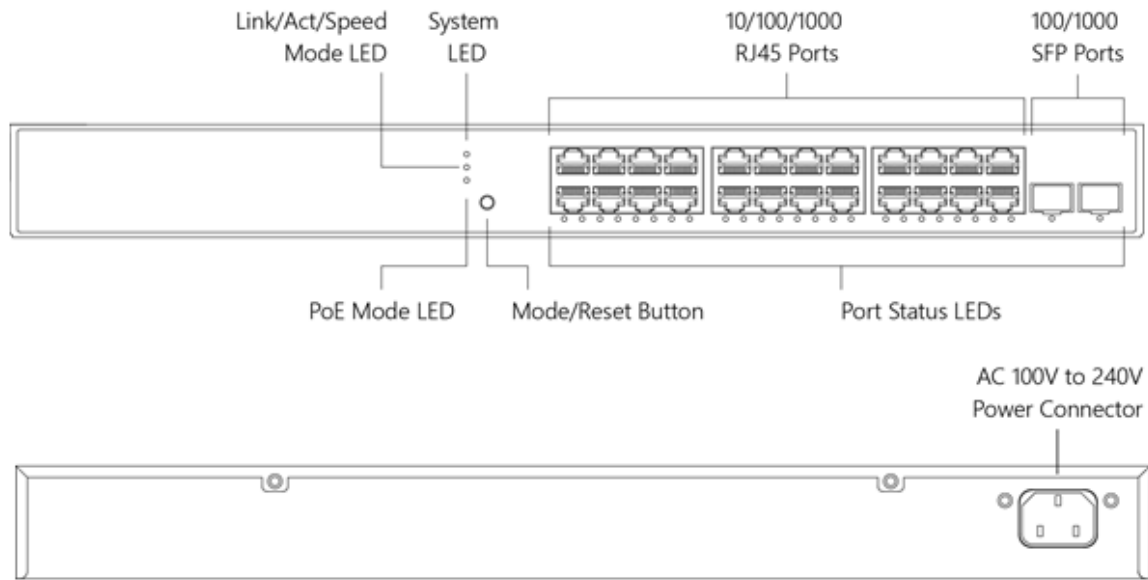

Figure 3: SM24TAT2SA Front and Back Panels

## LED Descriptions

The LEDs on the front panel provide switch status checking and monitoring. There are three types of LEDs as follows:

### System LED

Indicates if the switch is powered up correctly, indicates if there is a system alarm triggered for troubleshooting.

### Mode LEDs

Indicate the mode of all ports on the switch. You can press the **Mode/Reset** button sequentially to switch between the two modes (Link/Activity/Speed mode and PoE mode).

### Port Status LEDs

Indicate the current status of each port. You can check these LEDs to understand the port status in different modes, after changing the mode by pressing the **Mode/Reset** button.

The LED indicators are described in the following tables.

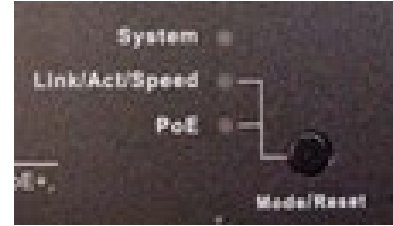

**Table 1: System LED**

LED	Color	State	Description
System	Green	On	The switch is powered ON correctly.
		Off	The switch is not receiving power.
	Red	On	An abnormal state, such as exceeding operating temperature range, has been detected in the switch.

**Table 2: Mode LEDs**

LED	Color	State	Description
Link/Act/Speed	Green	On	The Port Status LEDs display link status, network activity, and speed of each port.
PoE	Green	On	The RJ45 Port Status LEDs are displaying PoE powering status of each port.

By pressing the **Mode/Reset** button for less than 2 seconds to change LED modes (Link/Act/Speed Mode or PoE Mode) you can check the port status by reading the LED behaviors per the table below.

**Table 3: Port Status LEDs**

When Link/Act/Speed Mode LED Lit			
LED	Color	State	Description
RJ45 Ports	Green	On	The port is enabled and established a link to connected device, and the connection speed is 1000Mbps.
	Green	Blinking	The port is transmitting/receiving packets, and the connection speed is 1000Mbps.
	Amber	On	The port is enabled and established a link to connected device, and the connection speed is 10/100Mbps.
	Amber	Blinking	The port is transmitting/receiving packets, and the connection speed is 10/100Mbps.
	--	Off	The port has no active network cable connected, or it is not established a link to connected device. Otherwise, the port may have been disabled through the switch user interface.
SFP Ports	Green	On	The port is enabled and established a link to connected device, and the connection speed is 1000Mbps.
	Green	Blinking	The port is transmitting/receiving packets, and the connection speed is 1000Mbps.
	Amber	On	The port is enabled and established a link to connected device, and the connection speed is 100Mbps.
	Amber	Blinking	The port is transmitting/receiving packets, and the connection speed is 100Mbps.
	--	Off	The port has no active network cable connected, or it is not established a link to connected device. Otherwise, the port may have been disabled through the switch user interface.

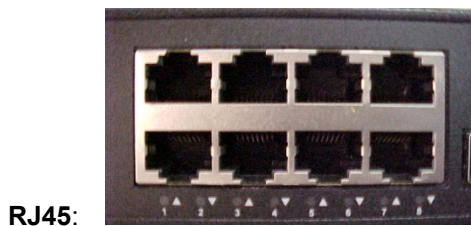

When PoE Mode LED Lit			
LED	Color	State	Description
RJ45 Ports	Green	On	The port is enabled and supplying power to connected device.
	Amber	On	An abnormal state, such as overload status, has been detected in the switch.
	--	Off	The port has no active network cable connected, or it is not connected a PoE PD device. Otherwise, the port may have been disabled through the switch user interface.

## Mode/Reset Button

By pressing the Mode/Reset button for certain period of time, you can perform these tasks.

- **Change Port Status LED Mode:** to read the port status correctly in the two different modes (PoE mode or Link/Act/Speed mode).
- **Reset the Switch:** to reboot and get the switch back to the previous configuration settings saved. The First Time Wizard displays again after pressing the Reset button.
- **Restore the Switch to Factory Defaults:** to restore the original factory default settings back to the switch.

**Note:** Based on the table below, you can judge which task is being performed by reading the LED behaviors while pressing the Mode/Reset button. Once the LED behaviors are correctly displayed, you may release the button.

**Table 4: Mode/Reset Button Descriptions**

Task to Perform	Press Button for ..	SYS LED Behavior	Port Status LED Behavior
Change LED Mode	0 ~ 2 seconds	ON Green	LED status will be changed according the mode selected.
Reset the Switch	2 ~ 7 seconds	Blinking Green	ALL LEDs Are OFF.
Restore to Defaults	7 ~ 12 seconds	Blinking Green	ALL LEDs Stay ON.

Press the **Reset** button until all port LEDs light, then release the **Reset** button. This will set the unit back to its factory default IP address; log back in to display the startup wizard.

## Chapter 3 Installation

### Package Contents

Carefully unpack the package contents. Make sure no items are missing or damaged. Please save the packaging for possible future use.

- The Switch
- AC Power cord (country specific)
- Four adhesive rubber feet
- Printed Quick Start Guide
- 19" Rack Mount brackets

**Caution:** The switch is an indoor device. If it is to be used with outdoor devices such as outdoor IP cameras or outdoor Wi-Fi APs, then you are strongly suggested to install a surge protector or surge suppressor to protect the switch.

Compliant with 802.3at in Environment A when using an isolated power supply. For 802.3at Environment B applications, i.e., building to building, copper to copper endpoint connections: 1) use an Ethernet network isolator module (PoE disabled), or 2) use mid-span injector (s), e.g., MIL-L100i, L1000i-at, between this switch's PSE port and link partner PD port.

### Mounting the Switch on a Wall

**Step 1:** Install user-supplied screws on the appropriate location on the wall and be aware of the dimensional limitation of the screws.

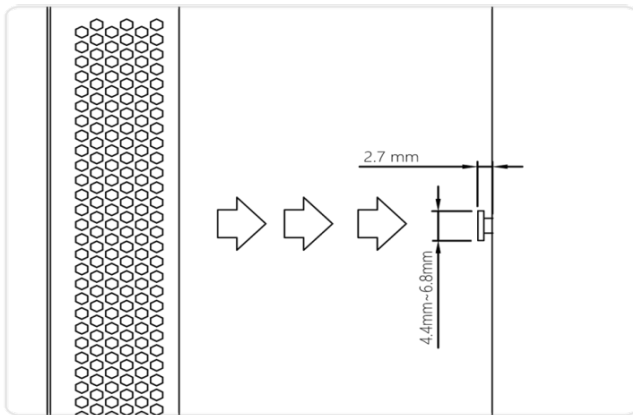

Figure 4: Install screws to the wall

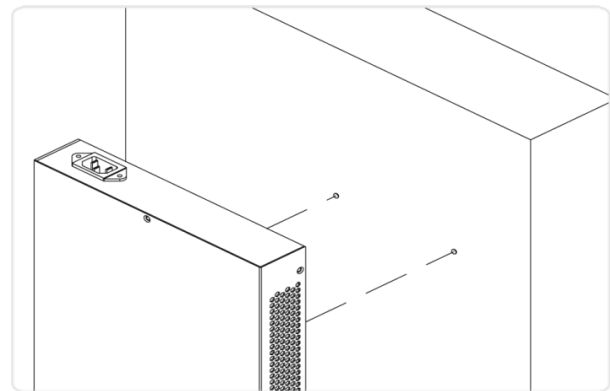

Figure 5: Attaching switch to the wall

**Step 2:** Make sure that the switch is attached securely to wall.



## Mounting the Switch on Desk or Shelf

**Step 1:** Verify that the workbench is sturdy and reliably grounded.

**Step 2:** Attach the four adhesive rubber feet to the bottom of the switch.

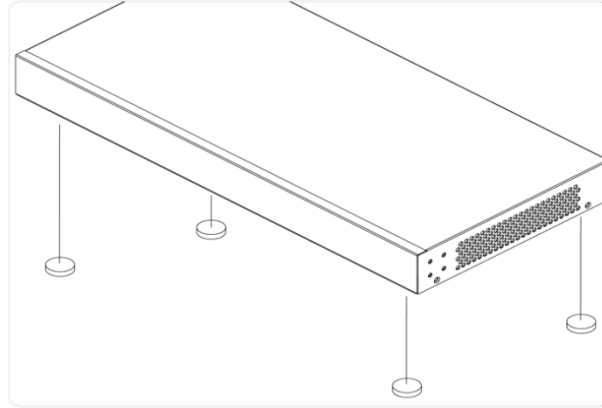

**Figure 6: Attaching the Rubber Feet**

## Mounting the Switch in a 19-inch Rack

**Step 1:** Attach the mounting brackets to both sides of the chassis. Insert screws and tighten them with a screwdriver to secure the brackets.

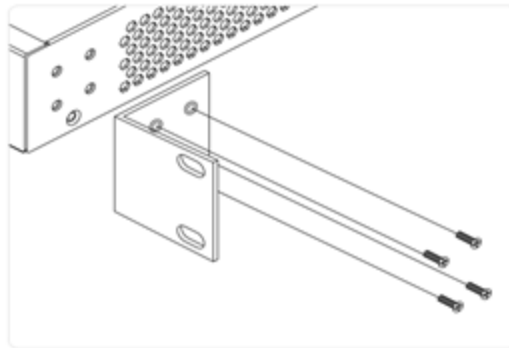

**Figure 7: Attaching Brackets to the Switch**

**Step 2:** Place the switch on a rack shelf in the rack. Push it in until the oval holes in the brackets align with the mounting holes in the rack posts.

**Step 3:** Attach the brackets to the posts. Insert screws and tighten them.

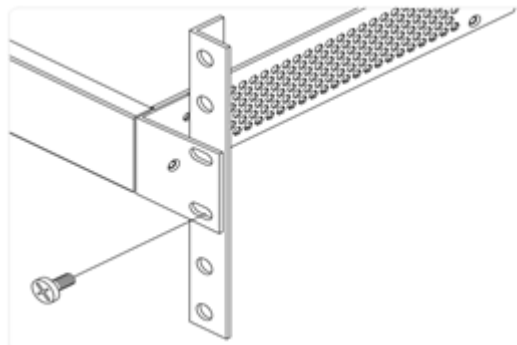

**Figure 8: Attaching Brackets to the Rack Post**

## Installing SFP Modules

You can install or remove a mini-GBIC SFP module from a SFP port without having to power off the switch.

**Note:** with Port Mode set to Auto, these Copper SFPs can be used: TN-SFP-T-MG, TN-GLC-T-MG, and TN-GLC-T.

**Note:** see the related SFP device manual for important Safety warnings. See the Lantronix [SFP page](#) for our full line of SFP transceivers. See the [FOA webpage](#) for additional information. The Fiber Optic Association, Inc. is an international non-profit educational association chartered to promote professionalism in fiber optics through education, certification and standards.

**Step 1:** Insert the module into the SFP port.

**Step 2:** Press firmly to ensure that the SFP module seats into the connector.

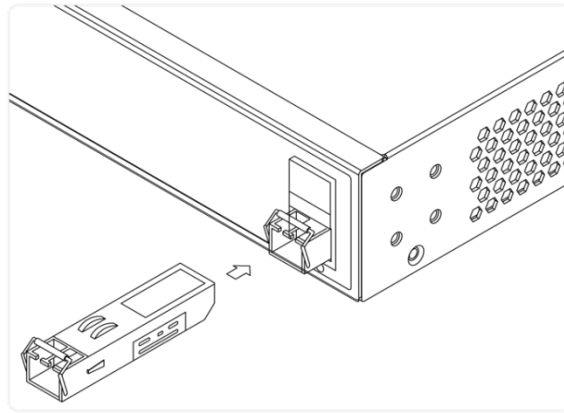

Figure 9: Installing an SFP Module into an SFP Port

## Connecting Devices

Firmware v1.01.1209 adds the PoE Force mode feature. **Note:** only connect PDs which support power input in the 48~56V range to prevent damage to PDs. When the port is changed to Force mode, the port's PoE LED lights immediately. See the *Web User Guide* for details.



Figure 10: RJ-45 and SFP Ports

## Connecting the AC Power Cord

The switch ships with a country specific AC Power cord. To order the corresponding country specific power cord, add the Country Code extension to the end of the SKU (e.g., SM8TAT2SA-NA = North America, -LA = Latin America, -EU = Europe, -UK = United Kingdom, -SA = South Africa, -JP = Japan, -OZ = Australia, -BR = Brazil).

**Step 1:** Connect the AC power cord to the AC power receptacle of switch.

**Step 2:** Connect the other end of the AC power cord to the AC power outlet.

**Step 3:** Check the SYS LED. If it is ON, the power connection is correct.

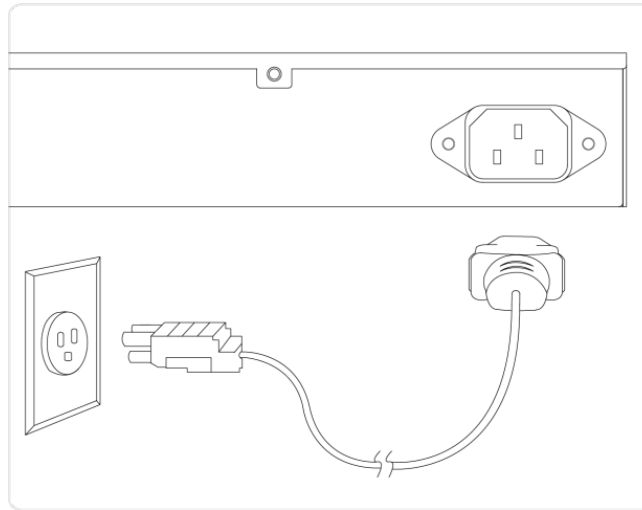

**Figure 11: Connecting AC Power Cord**

## Chapter 4 Initial Switch Configuration

### Initial Switch Configuration via Web Browser

When you power up the switch the first time, a First Time Wizard is presented. On subsequent power ups, you can perform the initial switch configuration using a web browser. See the Quick Start Guide for First Time Wizard information. For managing other switch features, refer to the Web User Guide for details.

For the initial configuration stage, you must reconfigure your PC's IP address and subnet mask so as to make sure the PC can communicate with the switch. After changing PC's IP address (for example, 192.168.1.250), then you can access the Web interface of the switch using the switch's default IP address as shown below.

The initial switch configuration via web browser procedure is as follows:

---

**Note:** The switch's factory default IP address is **192.168.1.77** and the factory default Subnet Mask is **255.255.255.0**.

---

1. Power up the PC that you will use for the initial configuration. Make sure the PC has an Ethernet RJ45 connector to be connected to the switch via standard Ethernet LAN cable.
2. Reconfigure the PC's IP address and Subnet Mask as below, so that it can communicate with the switch. To change the PC's IP address for a PC running Windows® 7/8.x/10, is as follows:
  - a) Type "*network and sharing*" into the **Search box** in the **Start Menu**.
  - b) Select **Network and Sharing Center**.
  - c) Click on **Change adapter settings** on the left of PC screen.

---

**Note:** You can skip steps a to c, by pressing **WinKey+R** and type "*ncpa.cpl*" command to get to step d directly.

---

- d) Right-click on your local adapter and select **Properties**.
- e) In the **Local Area Connection Properties** window highlight **Internet Protocol Version 4 (TCP/IPv4)** then click the **Properties** button.

---

**Note:** Be sure to record all your PC's current IP settings to be able to restore them later.

---

- f) Select the radio button **Use the following IP address** and enter in the IP for the PC (e.g., any IP address not in use, and in between *192.168.1.2* and *192.168.1.254*), Subnet mask (e.g., *255.255.255.0*), and Default gateway that corresponds with your network setup. Then enter your Preferred and Alternate DNS server addresses.
  - g) Click **OK** to change the PC's IP address.
3. Power up the switch to be initially configured and wait until it has finished its start-up processes.
  4. Connect the PC to any port on the switch using a standard Ethernet cable, and check the port LED on the switch to make sure the link status of the PC is OK.
  5. Run your Web browser on the PC; enter the factory default IP address, to access the switch's Web interface.

If your PC is configured correctly, you will see the login page of the switch as shown below.



**Figure 11: Web Interface Login page**

If you do not see the above login page, perform these steps:

- Refresh the web page.
- Check to see if there is an IP conflict issue.
- Clean browser cookies and temporary internet files.
- Check your PC settings again and repeat step 2.

6. Enter the factory default username and password in login page.
7. Click “Login” to log into the switch.

---

**Note:** The factory default Username and Password of the switch are both **admin**.

---

See the *SMxTAT2SA Web User Guide* for more information.

### **Initial Switch Configuration via CLI**

The CLI (Command Line Interface) can be accessed via telnet or SSH. See the *SMxTAT2SA CLI Reference* for more information.

## Chapter 5 Troubleshooting, Support, and Compliance

### Troubleshooting

The following table provides steps to troubleshoot problems by taking actions based on the suggested solutions.

**Table 5: Troubleshooting Procedure**

Symptom	Possible Cause	Suggested Solution
SYSTEM LED is Off	The switch is not receiving power.	<ol style="list-style-type: none"> <li>1. Check if correct power cord is connected firmly to the switch and to the AC outlet socket.</li> <li>2. Perform power cycling the switch by unplugging and plugging the power cord back into the switch.</li> <li>3. If the LED is still off, try to plug power cord into different AC outlet socket to make sure correct AC source is supplied.</li> </ol>
SYSTEM LED is Red	An abnormal state was detected by the switch.	Check the system log to understand the abnormal state (e.g., exceeding operating temperature range) and take corresponding actions to resolve.
Port Status LED is Off in Link/Act/Speed Mode	The port is not connected, or the connection is not working.	<ol style="list-style-type: none"> <li>1. Check if the cable connector plug is firmly inserted and locked into the port at both the switch and connected device.</li> <li>2. Make sure the connected device is up and running correctly.</li> <li>3. If the symptom still exists, try different cable or different port to tell if it is related to the cable or specific port.</li> <li>4. Check if the port is disabled in the configuration settings via the Web user interface.</li> </ol>
Port Status LED is Off in PoE Mode	The port is not supplying power	<ol style="list-style-type: none"> <li>1. Check if the cable connector plug is firmly inserted and locked into the port at both the switch and connected device.</li> <li>2. Make sure the correct Ethernet cables are used.</li> <li>3. If symptom still exists, try different cable or different port to identify if it is related to the cable or specific port.</li> <li>4. Check if the port is disabled in the configuration settings via the Web user interface.</li> </ol>

## PoE Modes and Compliance

### PoE Deployment Environments A and B

IEEE802.3at-2009 defines two deployment environments in section 33.4.1:

**Environment A:** when both PSE and PD are located indoors, inside the same building. In this environment, there must be electrical isolation between the PoE circuitry and the data circuitry inside a PSE. Multi-port PSE's can all share the same ground isolation. Environment A is therefore an indoor PSE –indoor PD environment (a.k.a. indoor/indoor).

**Environment B:** when the PSE and PD are not located in the same building. In this environment there needs to be electrical isolation between PoE and data, as well as between every port in a multi-port PSE. This isolation between ports requirement de facto determines a completely separate power supply per port, which makes multi-port PSEs for outdoor PD deployment impractical. Environment B is therefore an indoor PSE-outdoor PD (a.k.a. indoor/outdoor) or outdoor PSE-outdoor PD (a.k.a. outdoor/outdoor) environment.

This means only single-port PSEs should normally be used when PDs are deployed outdoors. In summary, the PD-PSE environment is one of these three combinations:

1. PoE Source is indoor, PD is indoor (Env. A)
2. PoE Source is indoor, PD is outdoor (Env. B)
3. PoE Source is outdoor, PD is outdoor (Env. B)

Option 3 is the most challenging environment since both the PD and PSE are installed outdoors.

**Caution:** The switch is an indoor device. If it is to be used with outdoor devices such as outdoor IP cameras or outdoor Wi-Fi APs, then you are strongly suggested to install a surge protector or surge suppressor to protect the switch. The switch is compliant with 802.3at in Environment A when using an isolated power supply. For 802.3at Environment B applications, i.e., building to building, copper to copper endpoint connections: 1) use an Ethernet network isolator module (PoE disabled), or 2) use mid-span injector (s), e.g., MIL-L100i, L1000i-at, between this switch's PSE port and link partner PD port.

### Mode A vs. Mode B

Alternative A, also known as Mode A, uses the data pairs of an Ethernet link to deliver power. Data Pairs include pins 1,2 and 3,6. PSEs using Mode A supply a positive voltage to pins 1 and 2. Alternative B, also known as Mode B, uses the spare pairs to deliver power. Spare Pairs include pins 4,5 and 7,8.

### 802.3af/at Standard "compliant" vs "compatible" PDs

Knowing the difference between PoE "compliant" and "compatible" devices can help avoid interoperability and connectivity issues. Compliant PoE devices and compatible PoE devices are not held to the same 802.3af/at standard:

- 802.3af/at "compliant" PDs fulfill the IEEE strict requirement to support both Mode A and Mode B power modes.
- 802.3af/at "compatible" PDs typically can provide power using only Mode B.

### Typical PD Power Requirements

- 1.8 Watts: Lantronix' M/GE-ISW-SFP-01-PD (Class 1 Powered Device (0.44 - 3.84 Watts).
- 13W: IP Camera, VoIP Phone, Wireless Access Point, Networked Audio.
- 30W: IP Telephone, WiMAX Access Point, PTZ Camera, Remote Computer Terminal.
- 60W : Door Access System, Video Phone, Thin Client.
- 100W: Digital Signage Display, Point-of-Sale System, LCD TV, Computer Monitor.
- 200W: Larger TV, Larger Display, Larger Monitor, Laptop.

After eliminating basic network factors, ask your PD vendor for the PD's power supply mode and polarities supported and exact power consumption.

### Calculate PoE Power Budget

To calculate how many 802.3at devices the unit supports, divide the Total PoE Budget (130 Watts) by 30 Watts. To calculate the maximum number of 802.3af devices, divide the Total PoE Budget (130 Watts) by 15.4 Watts.

### Mixing POE and Non-POE Devices

You can mix POE and non-POE devices on the same POE switch (i.e., you can put PCs on the same POE switch as a SIP phone or a VOIP phone). The PSE (your switch) will only send power if requested by the PD.

### Ethernet and PoE Intra-Building Cabling Warnings

1. Ethernet cables are intended for intrabuilding use only. Connecting your Lantronix switch directly to Ethernet cables that run outside the building in which the switch is housed will void the user's warranty and could create a fire or shock hazard.
2. PoE cables are intended for intrabuilding use only. Connecting your Lantronix switch directly to PoE cables that run outside the building in which the switch is housed will void the user's warranty and could create a fire or shock hazard.
3. For outdoor PoE applications, we recommend using Lantronix' SI-IES-1200-LRT Unmanaged Hardened PoE+ Injector or SI-IES-111D-LRT Unmanaged Hardened PoE+ Injector/Converter Use of any other PoE injector will void the user's warranty and could create a fire or shock hazard.

### Legacy PD Detection / Capacitor Detection

Legacy PDs refers to powered devices manufactured before the IEEE standard was finalized and do not have the expected PD signature required by the PSE's detection signal. Such PDs usually feature large capacitance as the detection signature that does not completely comply with the 802.3af specs. By enabling this option, the switch will probe for legacy PDs and if a legacy PD is detected, the switch will provide power to the PD.

## Troubleshooting PoE Problems

1. Get as much detail as possible regarding the symptom, including any system messages from the PoE switch. For example, does a PD not power up at all, or does it power up briefly and then power down?
2. Determine if the trouble occurred on initial installation or after the PD had been working normally?
3. If the trouble started after the PD was working, what changed? Any hardware or software changes?
4. Verify that the port is not shut down, disabled, or errored.
5. Verify that the Ethernet cable from the PD to the switch port is good.
6. Verify that the total cable length from the switch front panel to the connected PD is not more than 100 meters. Some of the power from the switch port is dissipated in the cable due to wire resistance, especially on cables as long as 100 meters. Only the remaining power is available to the PD. The 100-meter limit for twisted-pair Ethernet cable assumes **a)** not more than four RJ-45 connection points in the transmission path, **b)** 90 meters of solid-strand Category 5 or 5e, and **c)** 10 meters of flexible multistrand cable (2-to-5 meters of multistrand Category 5 patch cords).
7. Verify that the PSE switch power budget can power the PD. If the switch power budget is depleted, additional PDs will not power-on when connected to a PoE port. Verify that the switch power budget (available PoE) is not depleted before or after the PD is connected. Verify that enough power is available for the PD type.
8. Verify if non-powered Ethernet devices can establish an Ethernet link on any port and that PoE devices do not power up on the same port.
9. Review alarms reported previously by system messages.
10. If a working IP Phone or WAP intermittently reloads or disconnects from inline power, verify all electrical connections from the switch to the PD. An unreliable connection results in power interruptions and intermittent PD operation, such as PD disconnects and reloads.
11. Check for changes in the electrical environment at the switch site. What is happening at the PD when the disconnect occurs? Check for error messages reported by the switch at the same time of the disconnect.



12. Pre-standard and post-standard VoIP phones may use different detection and connect / disconnect methods. Note that PD detection occurs when an Ethernet device is first connected to a PoE port. If a non-PoE device is connected to a PoE port, detection is deactivated. If the non-PoE device is later disconnected and replaced by a PD, the switch may not detect it immediately.
13. Verify that the PD is not causing an overcurrent condition on the port. Specifically: does the VoIP phone initially power on and then disconnect? If so, the problem may be an initial current surge that exceeds a current-limit threshold for the switch port. Some PDs may have excessive “surge in” current when first connected to a PoE port. The switch initially provides power to the port, and then quickly removes power due to a momentary overcurrent condition. The PD starts to power up, but then quickly powers down.
14. Most PoE switches have voltage and current regulators that detect an overcurrent threshold and disconnect power from the line. This prevents excessive current from being delivered by the PoE port, which could possibly result in damage to port-level components.
15. A variety of disturbances on the AC power line (mains) can cause odd PoE problems. The power supplies in various switches and PDs can react uniquely to AC input disturbances. AC disruption problems are usually temporary or one-time occurrences. For example, a specific switch or PD may reboot due to an AC power problem, while other switches or PDs may show a greater immunity to the problem. This is a typical occurrence during lightning storms or AC power maintenance. In a worst-case scenario, a PoE power supply may appear to shut down, with no PoE output voltage to any port. It's possible the switch's Ethernet functions appear normal, and only the PoE functions are disrupted or degraded, or the switch may power down completely due to the AC disturbance. PDs may exhibit unusual behavior. In such cases, power cycle the switch (unplug the switch, wait at least three seconds, then plug it back in. This will ensure a total system reset that should restore normal operation.
16. Check if related features (LLDP mode, CDP mode) are enabled.

### Recording Device and System Information

After performing the troubleshooting procedures, and before calling or emailing Technical Support, please record as much information as possible to help the Tech Support Specialist.

1. Select the SMxTAT2SA **Configuration > System > Information** menu path. From the CLI, use the **show** commands needed to gather the information below or as requested by the Tech Support Specialist.

2. Record SMxTAT2SA **Model Information:** Model Name: \_\_\_\_\_  
Hardware Version: \_\_\_\_\_ Mechanical Version: \_\_\_\_\_  
Firmware Version: \_\_\_\_\_ System Date: \_\_\_\_\_

3. Record the **LED Status:** \_\_\_\_\_  
\_\_\_\_\_

4. Provide additional information to your Tech Support Specialist. See the "Troubleshooting" section above.  
Your Lantronix service contract number: \_\_\_\_\_

Describe the failure: \_\_\_\_\_  
\_\_\_\_\_

A description of any action(s) already taken to resolve the problem (e.g., changing mode, rebooting, etc.):  
\_\_\_\_\_  
\_\_\_\_\_

The serial and revision numbers of all involved Lantronix products in the network:  
\_\_\_\_\_

A description of your network environment (layout, cable type, etc.): \_\_\_\_\_  
\_\_\_\_\_  
\_\_\_\_\_

The device history (i.e., have you returned the device before, is this a recurring problem, etc.): \_\_\_\_\_  
\_\_\_\_\_  
\_\_\_\_\_

Any previous Return Material Authorization (RMA) numbers: \_\_\_\_\_

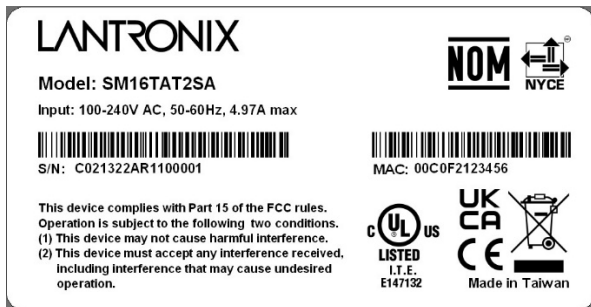

Device Label

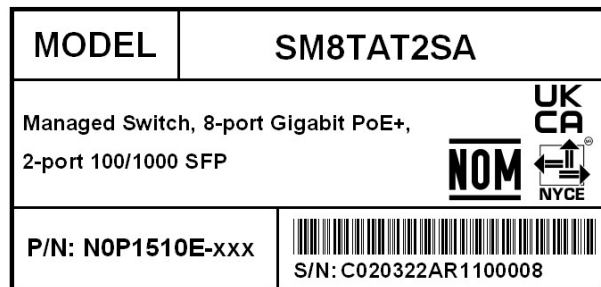

Box Label

## Compliance Information

### FCC Regulations

This equipment has been tested and found to comply with the limits for a Class A digital device, pursuant to part 15 of the FCC rules. These limits are designed to provide reasonable protection against harmful interference when the equipment is operated in a commercial environment. This equipment generates, uses, and can radiate radio frequency energy and, if not installed and used in accordance with the instruction manual, may cause harmful interference to radio communications.

Operation of this equipment in a residential area is likely to cause harmful interference, in which case the user will be required to correct the interference at the user's own expense.

This device complies with part 15 of the FCC Rules. Operation is subject to the following two conditions: (1) This device may not cause harmful interference, and (2) this device must accept any interference received, including interference that may cause undesired operation.

### Canadian Regulations

This digital apparatus does not exceed the Class A limits for radio noise for digital apparatus set out on the radio interference regulations of the Canadian Department of Communications.

Le présent appareil numérique n'émet pas de bruits radioélectriques dépassant les limites applicables aux appareils numériques de la Class A prescrites dans le Règlement sur le brouillage radioélectrique édicté par le ministère des Communications du Canada.

### Declaration of Conformity (DoC)

#### Declaration of Conformity

Manufacturer's Name: Lantronix, Inc.

Manufacturer's Address: 7535 Irvine Center Drive, Suite 100, Irvine, California 92618

Declares that the product(s): SM8TAT2SA, SM16TAT2SA, SM24TAT2SA

Conform(s) to the following Product Regulations:

FCC Part 15 Class A, EN 55032:2012, EN 55024:2010

Directive 2014/30/EU, Directive 2015/863/EU

Low-Voltage Directive 2014/35/EU

IEC62368-1/EN62368-1

2011/65/EU EN 50581:2012

Normas Oficiales Mexicanas (NOM)

With the technical construction on file at the above address, this product carries the CE Mark

I, the undersigned, hereby declare that the equipment specified above conforms to the above Directive(s) and Standard(s).

Place: Irvine, California

Date: July 28, 2021

Signature: *Fathi Hakam*

Full Name: Fathi Hakam

Position: Vice President of Engineering

### **SMxTAT2SA EU Compliance**

The equipment is in accordance with the procedures as given in European Council Directive 2014/30/EU. The equipment Passed the test performed according to European Standard EN 55032:2012/AC:2013 Class A, EN61000-3-2:2014, EN 61000-3-3:2013 and EN 55024:2010 (IEC 61000-4-2 Edition 2.0 2008-12, IEC 61000-4-3 Edition 3.2 2010-04, IEC 61000-4-4 Edition 3.0 2012-04, IEC 61000-4-5 Edition 3.0 2014-05, IEC 61000-4-6 Edition 4.0 2013-10, IEC 61000-4-8 Edition 2.0 2009-09, IEC 61000-4-11 Edition 2.0 2004-03) and Australian Standard AS/NZS CISPR 32:2013 Class A.

### **SMxTAT2SA Safety Compliance**

Standard: IEC62368-1

UL Listed

Normas Oficiales Mexicanas (NOM)

### **SMxTAT2SA Summary of compliance with National Differences:**

Standard: IEC62368-1

This product fulfils the requirements of IEC62368-1

The equipment is in accordance with the procedures as given in European Council Directive 2014/30/EU.

The equipment Passed the test performed according to European Standard EN 55032:2012/AC:2013 Class A, EN61000-3-2:2014, EN 61000-3-3:2013 and EN 55024:2010

(IEC 61000-4-2 Edition 2.0 2008-12, IEC 61000-4-3 Edition 3.2 2010-04,

IEC 61000-4-4 Edition 3.0 2012-04, IEC 61000-4-5 Edition 2.0 2005-11,

IEC 61000-4-6 Edition 4.0 2013-10, IEC 61000-4-8 Edition 2.0 2009-09,

IEC 61000-4-11 Edition 2.0 2004-03) and

Australian Standard AS/NZS CISPR 32:2013 Class A.

### **SMxTAT2SA 47 CFR FCC Rules and Regulations**

Part 15 Subpart B – Class A Digital Device and Canada Standard ICES-003 Issue 6, Class A

## Electrical Safety Warnings

### Electrical Safety

**IMPORTANT:** This equipment must be installed in accordance with safety precautions.

### Elektrische Sicherheit

**WICHTIG:** Für die Installation dieses Gerätes ist die Einhaltung von Sicherheitsvorkehrungen erforderlich.

### Elektrisk sikkerhed

**VIGTIGT:** Dette udstyr skal installeres i overensstemmelse med sikkerhedsadvarslerne.

### Elektrische veiligheid

**BELANGRIJK:** Dit apparaat moet in overeenstemming met de veiligheidsvoorschriften worden geïnstalleerd.

### Sécurité électrique

**IMPORTANT:** Cet équipement doit être utilisé conformément aux instructions de sécurité.

### Sähköturvallisuus

**TÄRKEÄÄ:** Tämä laite on asennettava turvaohjeiden mukaisesti.

### Sicurezza elettrica

**IMPORTANTE:** questa apparecchiatura deve essere installata rispettando le norme di sicurezza.

### Elektrisk sikkerhet

**VIKTIG:** Dette utstyret skal installeres i samsvar med sikkerhetsregler.

### Segurança eléctrica

**IMPORTANTE:** Este equipamento tem que ser instalado segundo as medidas de precaução de segurança.

### Seguridad eléctrica

**IMPORTANTE:** La instalación de este equipo deberá llevarse a cabo cumpliendo con las precauciones de seguridad.

### Elsäkerhet

**OBS!** Alla nödvändiga försiktighetsåtgärder måste vidtas när denna utrustning används.

**Lantronix Corporate Headquarters**

7535 Irvine Center Drive  
Suite100  
Irvine, CA 92618, USA  
Toll Free: 800-526-8766  
Phone: 949-453-3990  
Fax: 949-453-3995

**Technical Support**

+1.952.358.3601, 1.800.260.1312, or <https://www.lantronix.com/technical-support/>

**Sales Offices**

For a current list of our domestic and international sales offices, go to the Lantronix web site at [www.lantronix.com/about/contact](http://www.lantronix.com/about/contact).