



Features

Power (W)	2 x 3W
Lamp Type	LED
Input Voltage	3.6V - 24VDC
Frequency	
LED Type	
Battery Type	
Working Time	
Charging Time	



Description

- Suitable for use in wet locations
- High impact thermoplastic housing
- Clear polycarbonate lens for bright illumination
- Wall and ceiling mounting
- Super bright 2 x 3W LED
- UL and ULC Approved

Technical Drawing

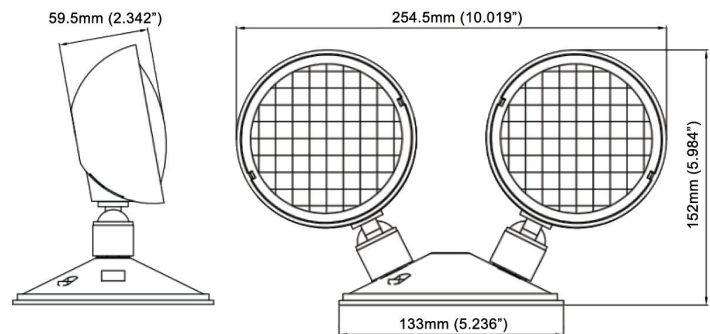

Ordering Information

Model	Description
EL-7030BWP	Weather Proof Double LED Remote Head

**NEW YORK CITY
APPROVED**



Canada
25 Interchange Way Vaughan, ON L4K 5W3
Telephone: (905) 660-4655 | Fax: (905) 660-4113

U.S.A.
4575 Witmer Industrial Estates Niagara Falls, NY 14305
Toll Free: (888) 660-4655 | Fax Toll Free: (888) 660-4113



THIS INFORMATION IS FOR MARKETING PURPOSES ONLY AND NOT INTENDED TO DESCRIBE THE PRODUCTS TECHNICALLY.

For complete and accurate technical information relating to performance, installation, testing and certification, refer to technical literature. This document contains intellectual property of Mircom. The information is subject to change by Mircom without notice. Mircom does not represent or warrant correctness or completeness. All rights reserved. All other trademarks and registered trademarks are properties of their respective owners.