

AVC-MT91FT

FIXED LENS MINIATURE CAMERA

HD-TVI
CAMERA



FUNCTION

- TVI SOLUTION
- 1/2.8" SENSOR
- 2.1 MEGAPIXELS
- 3.7mm MEGAPIXEL PINHOLE LENS
- VIDEO OUTPUT: HD 1080P@30FPS/25FPS
- 2D-NR/3D-NR/SMART NR/SENSE-UP/DIGITAL
- ZOOM FUNCTIONS ETC.
- SUPPORT UTC FUNCTION TO REMOTE CONTROL
- OSD MENU
- DUAL VIDEO-OUT (HD-TVI / ANALOG)
- DC 12V

DIMENSION

* Unit : mm (Inch)

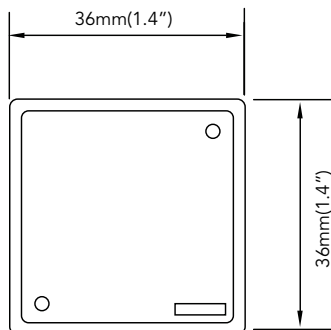
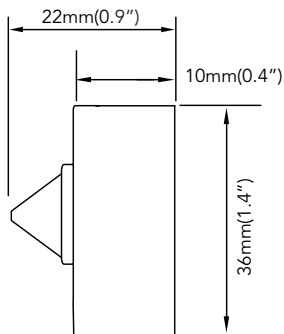

SPECIFICATION

DESCRIPTION	NTSC	PAL
IMAGE SENSOR	1/2.8" MEGA PIXEL SENSOR	
EFFECTIVE PIXEL	976(H) x 494(V)	976(H) x 582(V)
SCANNING SYSTEM	2.1 MEGAPIXELS	
SYNCHRONIZATION	INTERNAL	
HORIZONTAL RESOLUTION	PAL:1920X1080P 25F/S NTSC: 1920X1080P 30F/S	
VIDEO OUTPUT	1 HD-TVI OUTPUT / 1.0Vp-p75Ω	
S/N RATIO	MORE THAN 50dB (AGC OFF)	
LENS	3.7mm MP PINHOLE LENS	
ELECTRONIC SHUTTER	1/25 ~ 1/50000sec	
BACKLIGHT COMPENSATION	OFF	
WHITE BALANCE	ATW	
DAY & NIGHT	AUTO	
PRIVACY MASKING	OFF	
DNR	AUTO	
SMART IR	N/A	
SENS UP	N/A	
MOTION	N/A	
DEFECT DET	OFF	
IR LED	N/A	
INPUT VOLTAGE	DC 12V(±10%)	
POWER CONSUMPTION	80mA(MAX)	
OPERATING TEMP. / HUM.	-4°F ~ 140°F / MAX 90% RH	
STORAGE TEMP. / HUM.	-20°C ~ +60°C / MAX 90% RH	