

Figure 1: Dimensions of TX3-T-KIOSK2 with TX3-TOUCH-S22

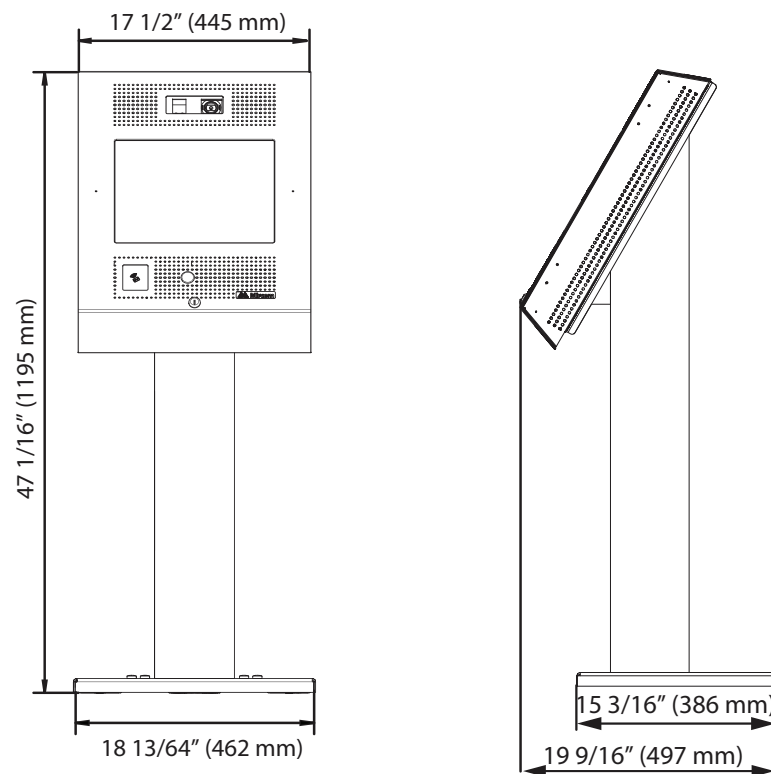

Figure 2: Dimensions of TX3-T-KIOSK2 with TX3-TOUCH-S15-B  
TX3-TOUCH-S15 can also be used with this stand.

For more details, see LT-996 and LT-969 on the Mircom website and the USB flash.  
Mircom technical support: 1-888-647-2665

**Attention:** The stand is heavy. Never attempt to lift this product by yourself. At least two people should lift it together.

To ensure that there is enough room for installing the stand, leave at least 4" (102 mm) clearance between the back of the floor bracket and the wall.

Avoid placing the Touch Screen in direct sunlight.  
Install the power supply outside the enclosure.

The stand mounts to the floor inside the building near the entrance, close to the building power source and telephone infrastructure. Access for the power and communication cables is provided through a cutout in the floor bracket.

The kit includes:  
1 x stand  
1 x floor bracket  
8 x screws for attaching the stand to the floor bracket  
8 x screw covers  
8 x screw bases  
6 x screws for attaching the Touch Screen to the stand  
Weight: 65.5 lb (30 kg)

You need:  
4 bolts to attach the floor bracket to the floor. The bolts need to fit holes that are 13/32" (10 mm) in diameter.

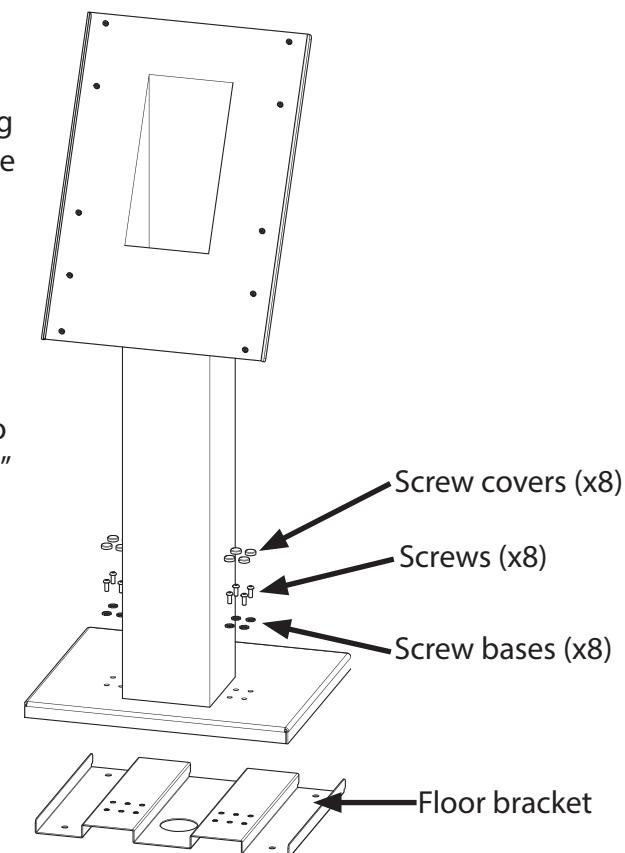

Figure 3: Components of TX3-T-KIOSK2

## 1 ATTACH THE FLOOR BRACKET TO THE FLOOR

1. Ensure that the floor bracket is aligned with the electrical conduit.
2. Using the floor bracket as a template, trace an opening on the floor for the cutout and mark the 4 floor bracket mounting hole locations as shown in Figure 4.

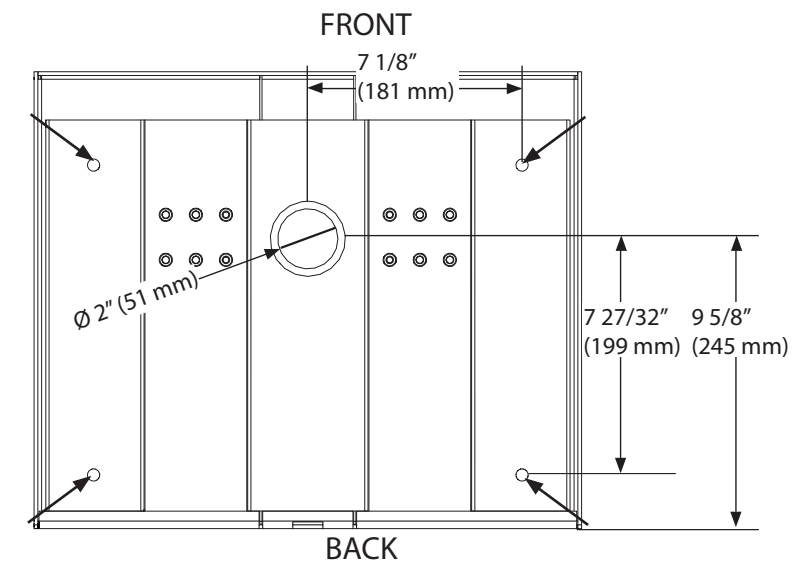

Figure 4: TX3-T-KIOSK2 dimensions (from below)

3. Cut an opening in the floor for the electrical and communication cables.
4. Run the wires through the floor bracket opening.
5. Secure the floor bracket to the floor using 4 bolts through the floor bracket mounting holes shown in Figure 4. The holes are 13/32" (10 mm) in diameter.

## 2 FIT THE STAND ON THE FLOOR BRACKET

**Attention:** The stand is heavy. Never attempt to lift this product by yourself. At least two people should lift it together.

1. Run the wires through the stand and out the hole at the top.
2. Place the stand on the floor bracket, and slide it forwards so that it rests on top of the floor bracket.
3. Ensure that the floor bracket fits into the back lip of the stand.

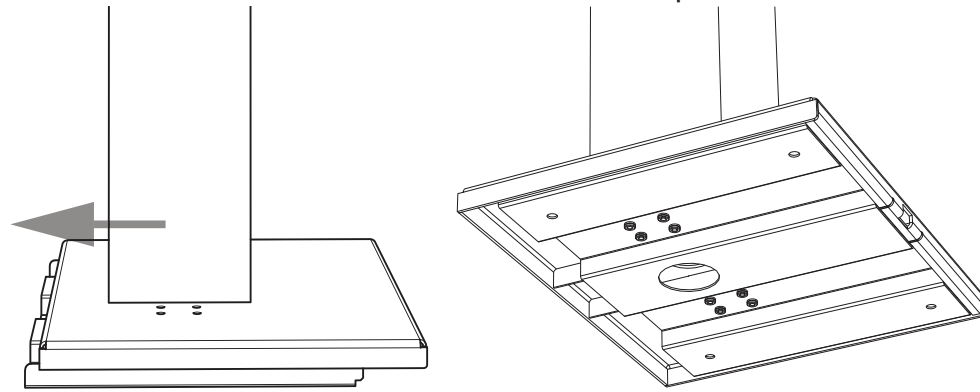

Figure 5: Fit the stand on the floor bracket

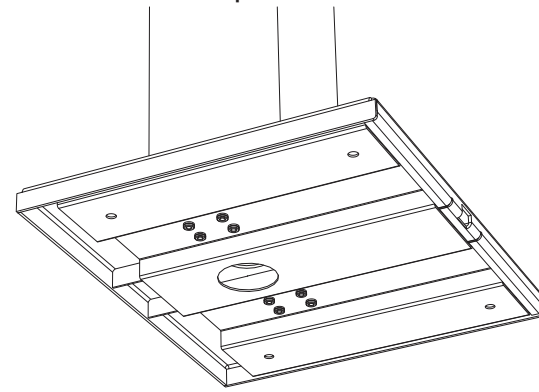

Figure 6: The stand on the floor bracket (as seen from below)

4. Secure the stand onto the floor bracket using the screw cover bases, screws, and screw bases as show in Figure 7.

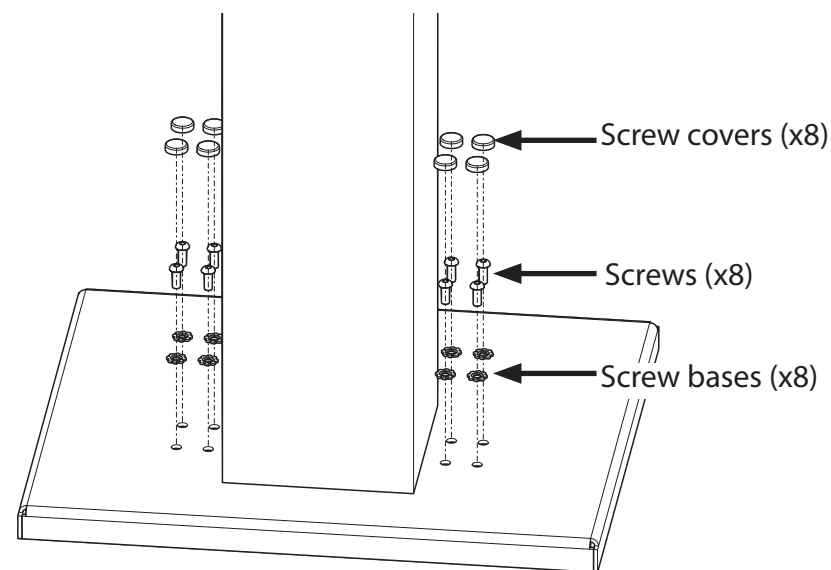

Figure 7: Attach the stand to the floor bracket

For more details, see LT-996 and LT-969 on the Mircom website and the USB flash. Mircom technical support: 1-888-647-2665

## 3 MOUNT THE TOUCH SCREEN ON THE STAND

**Attention:** The 22" Touch Screen enclosure is heavy. Never attempt to lift this product by yourself. At least two people should lift it together.

**Note:** Use only the **surface mount** Touch Screens (TX3-TOUCH-S22, TX3-TOUCH-S15, TX3-TOUCH-S15-B) with this stand.

1. Align the top two mounting holes of the Touch Screen with the top holes on the stand. See Figure 8.
2. Insert screws into the Touch Screen's top mounting holes and lower the Touch Screen so that the screws fit in the narrow part of the mounting holes.
3. Secure the Touch Screen with the remaining screws. Use 6 screws for the 22" Touch Screen and 4 screws for the 15" Touch Screen.

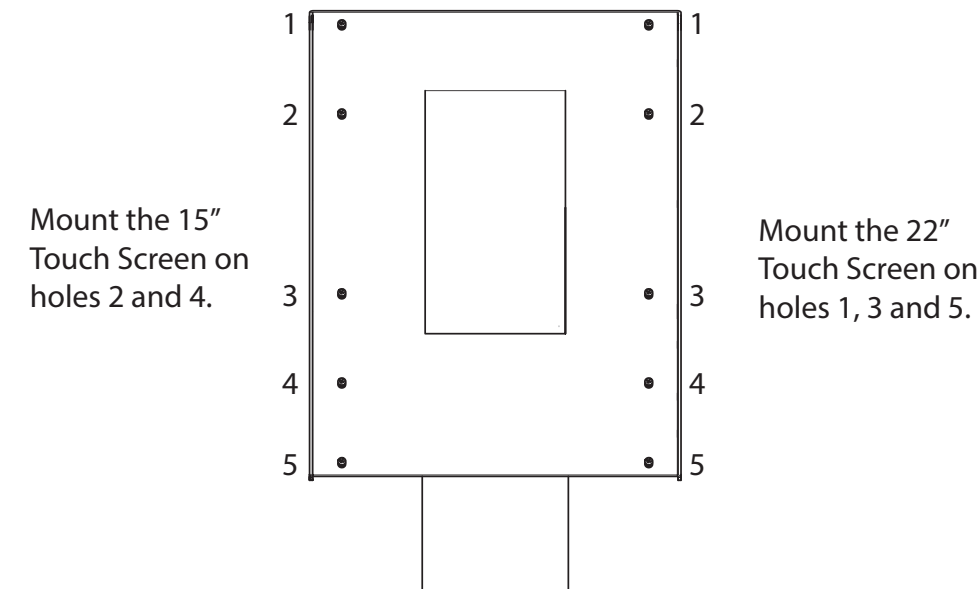

Figure 8: Mounting holes

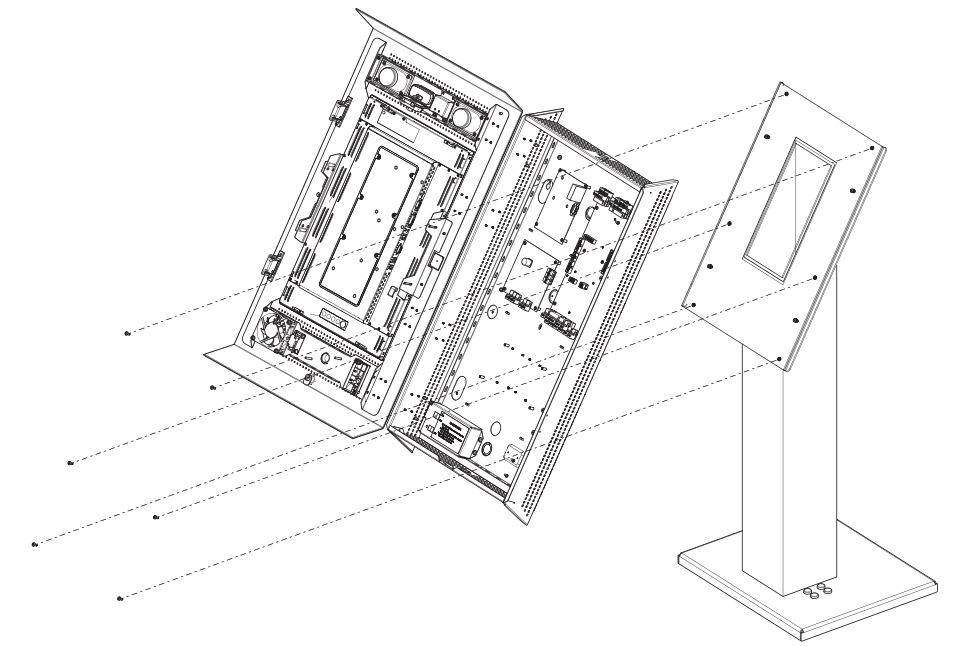

Figure 9: Mount TX3-TOUCH-S22 on the stand

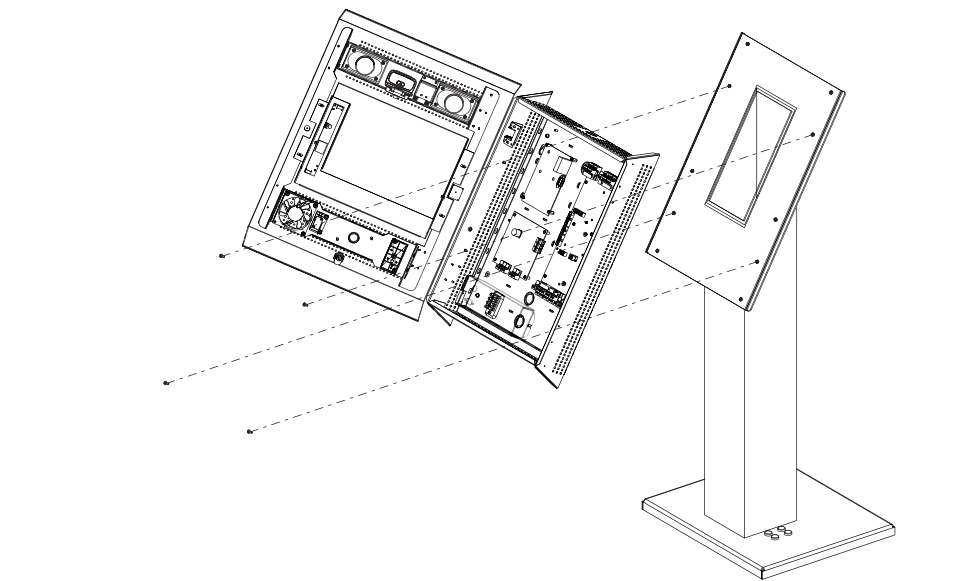

Figure 10: Mount TX3-TOUCH-S15-B on the stand

**Mircom**  
 CANADA - Main Office  
 25 Interchange Way  
 Vaughan, ON L4K 5W3  
 Tel: (888) 660-4655  
 (905) 660-4655  
 Fax: (905) 660-4113

US Address:  
 4575 Witmer Industrial Estates  
 Niagara Falls  
 NY 14305