

960H IR Mini Dome Camera Dome

Model : LBD1H

LIBERTÉ

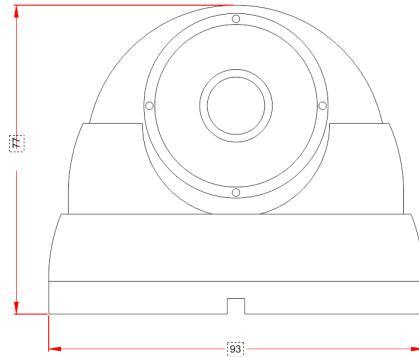

Feature:

- 700 TV lines of resolution
- 3.6mm fixed lens
- 24 high efficiency infrared LEDs
- Digital Wide Dynamic Range
- Ultra low power consumption
- 3-axis gimble for wall or ceiling mount
- IP65 compliant
- 5 year warranty

Installation:

- To prevent shock or damage to the water-resistant body, tighten all the screws and cover.
- Do not directly touch the front glass. To clean the dust by wiping with soft cloth and alcohol.
- Do not install camera where vibration is present.
- Do not install camera where temperature is above 120°F or below -4°F.
- Do not expose power or video connection to moisture or water.
- If camera is not functioning properly, please power off and contact the manufacturer.

Note: Non-regulated power supply may cause damage to camera.



Product Name	LBD1H
Video System	NTSC System
Sensor	1/3" Hi-sensitivity CCD Image Sensor
Numbers of Pixel	NTSC: 976H* 494V; PAL: 976H*582V
Horizontal Resolution	700TVL
Lens	3.6mm fixed lens
Day & Night	CDS Control
Sync.	Internal
Scanning	2:1 Interlace
S/ N Ratio	50dB Min.
White Balance	Auto (2500°K ~ 9500°K)
Backlight Compensation	OFF
Electronic Shutter	1/60(50)~1/500 (1/100K)
Auto Gain Control	ON
DWDR	Auto
Gamma Correction	0.45
DNR	2D Digital Noise Reduction
Video Output	1V p-p,75Ω
Min. Illumination	0Lux (LEDs ON), 0.001Lux (@50IRE/ F1.2)
IR Distance	82 ft.
Voltage Input	DC12V±10%
Power Current	75mA(IR LEDs off) 220mA (IR LEDs ON)
Operation Temp.	-4°F~120°F
Storage Temp.	-13°F~158°F
Humidity Range	20%~90% RH
Dimension	3.7" (Dia.) x 3.15" (H)
Net Weight	10.58 oz