

INSTALLATION INSTRUCTIONS

7000-DGK DOOR CORE DRILLING GUIDE FOR 1-3/4" DOORS

1. Mark a straight line across a piece of semi-rigid paper. This line will be the target for the Laser beam. Tape the paper to the edge of the door opposite the Hinge Cut-outs. Center the line you drew with the position you want the hole to terminate (figure 1).

Figure 1

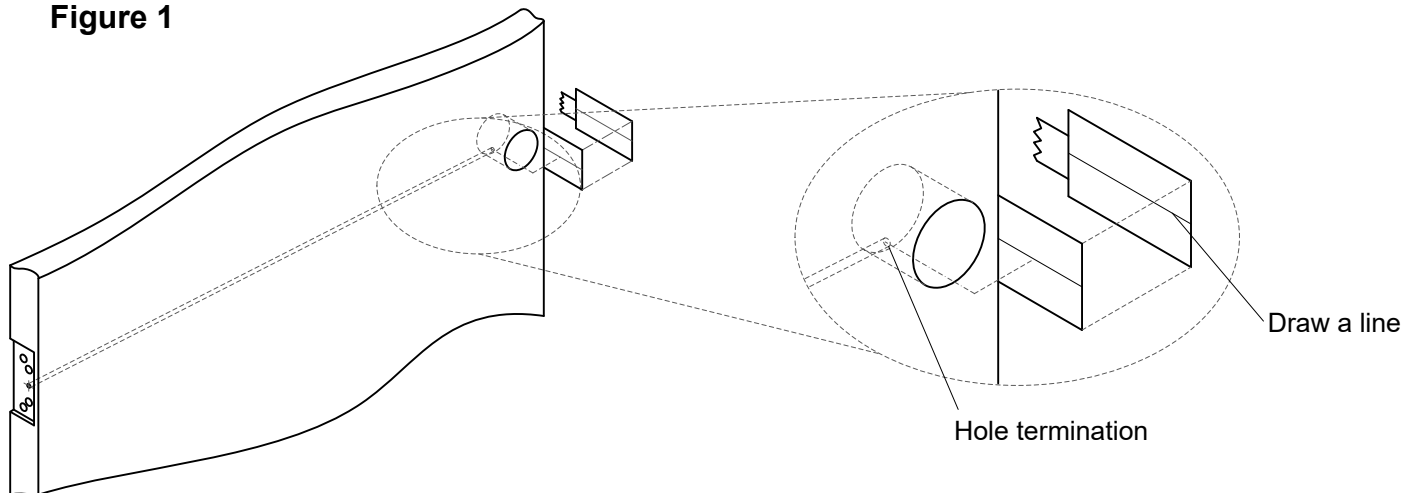

2. Place padded side of the Drill Guide against the door. Position pointed aluminum block between hinge mounting holes on the middle hinge cut-out (figure 2).

Figure 2

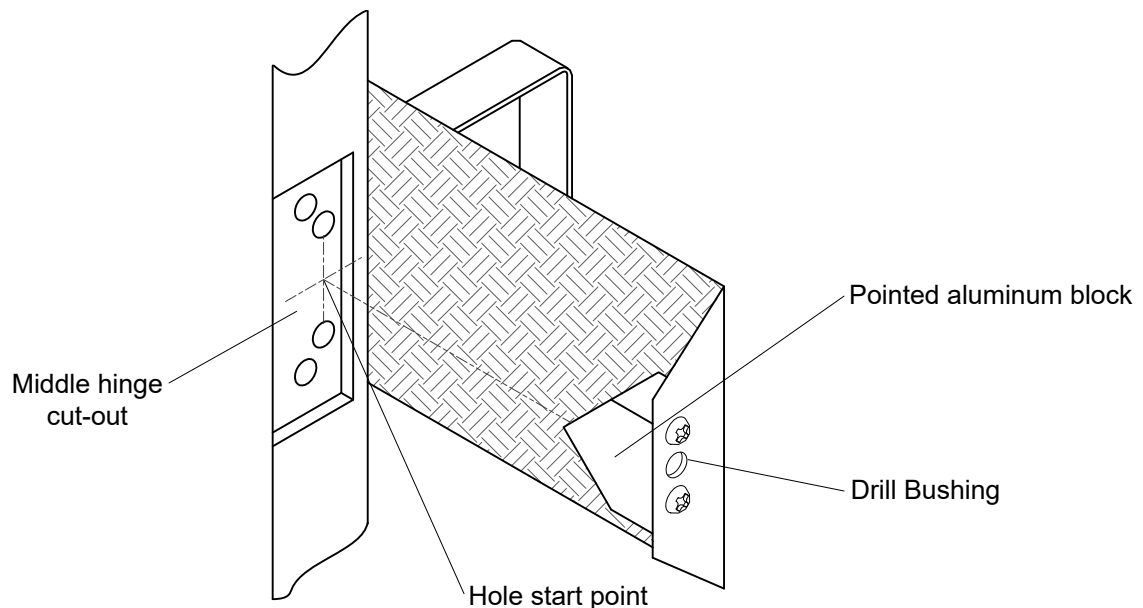

SDC IS NOT RESPONSIBLE FOR MIS-DRILLED DOORS

- Turn on and aim laser at target line. Once the laser beam is aligned with the target, hold the Drill Guide firmly against the door. Using the drill bit provided, drill a pilot hole into the door through the drill bushing in the end of the Laser Guide as deeply as possible (figure 3).

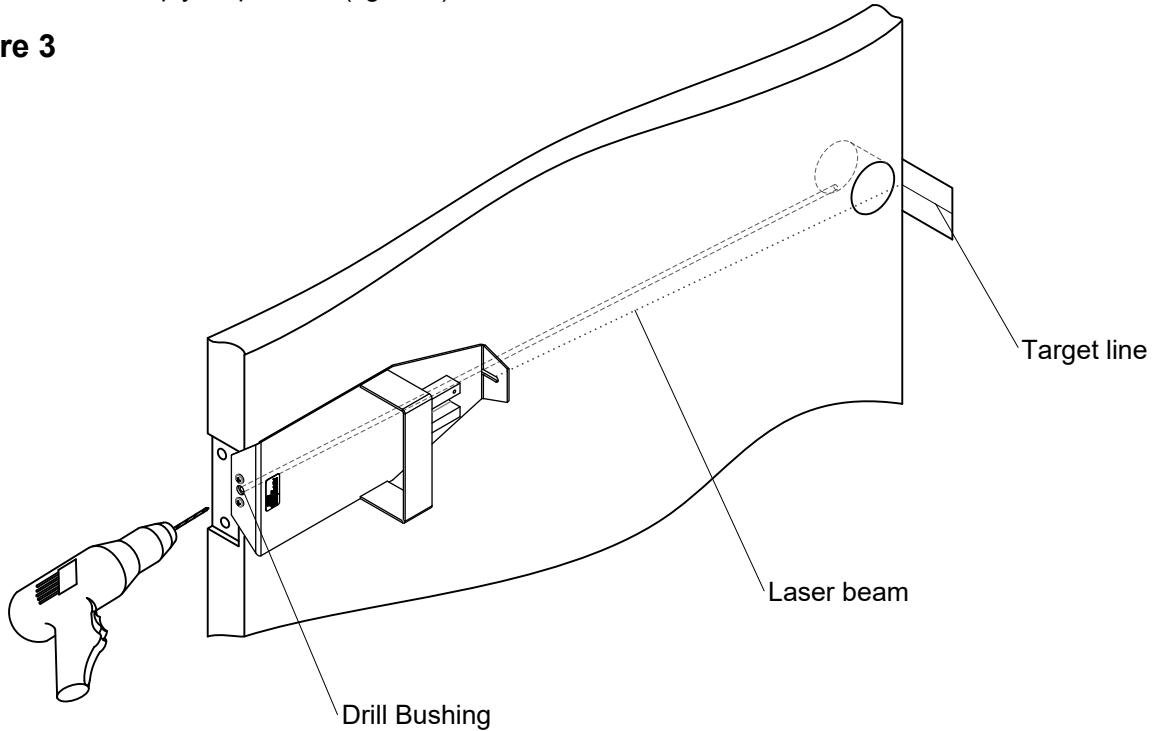
Figure 3

- Remove the Drill Guide from the door. Using a longer door coring drill bit, continue drilling the pilot hole to its termination point (figure 4).

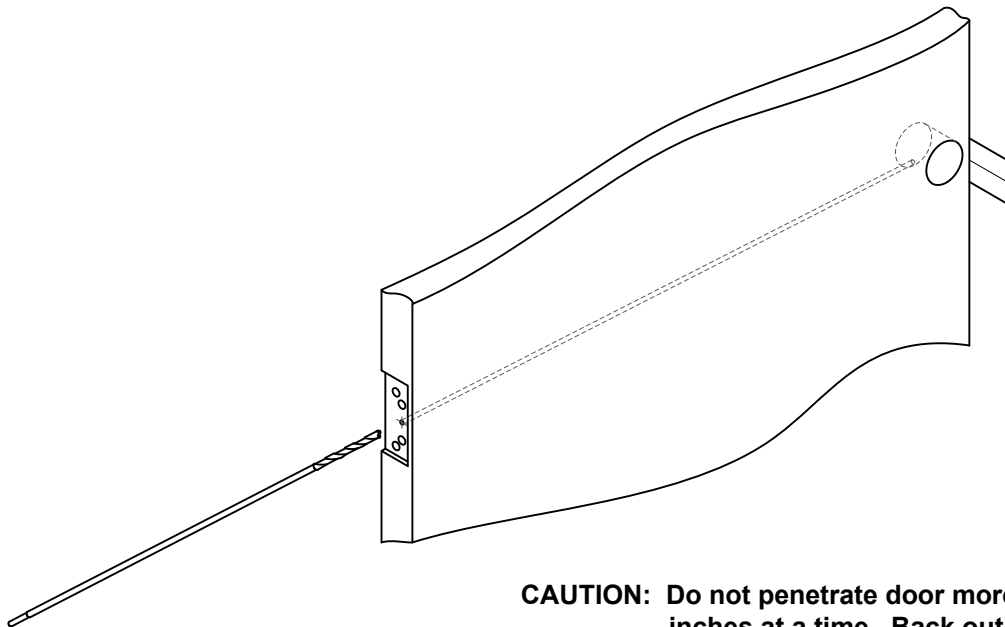
Figure 4

CAUTION: Do not penetrate door more than two inches at a time. Back out drill to drop debris after each and every 1" to 2" drilling of door.

SDC IS NOT RESPONSIBLE FOR MIS-DRILLED DOORS