



## Electrical and Mechanical Specifications

Physical	2.313" x 1.625" x 0.625" -	
Temp	Storage(-55°C to + 150°C) Operating(-40°C to +80°C)	
Humidity	95% (non-condensing)	
Power	Input	+5VDC @ 20mA
	Output	
Data I/O	Interface	Reader 0- 30VDC LED - 0 - 30VDC Analog 0 - 5 VDC

### FCC Part 15 COMPLIANCE

This device complies with part 15 of the FCC Rules.

Operation is subject to the following two conditions:

- (1) This device may not cause harmful interference, and
- (2) this device must accept any interference received, including interference that may cause undesired operation.

The CVX-OPTW is designed to provide isolation between different Wiegand signal sources.

The CVX-OPTW allows multiple readers and panels to be connected together.

The CVX-OPTW also allows systems with different voltage levels to be electrically connected together.

The CVX-OPTW may be cascaded to connect additional readers or panels to be connected.

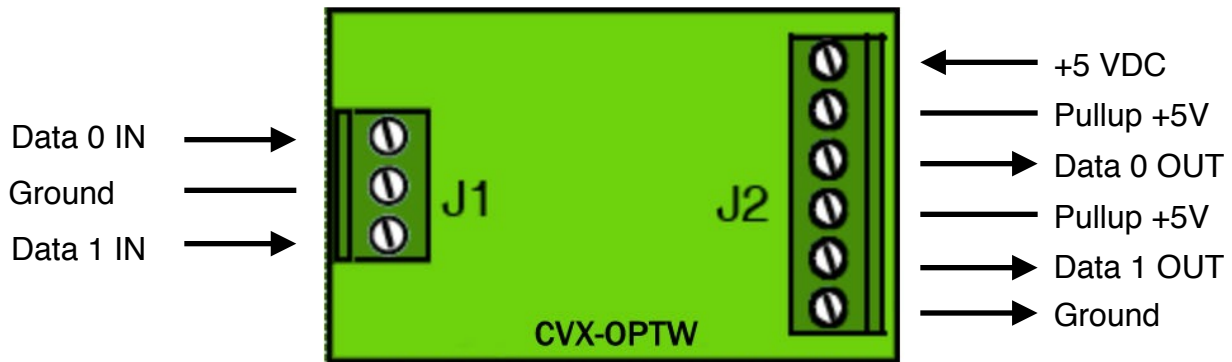

#### J1 Connector

- Gnd - Input Ground
- Data 0 In - Wiegand Data Input 5- 24 VDC
- Data 1 In - Wiegand Data Input 5 - 24 VDC

#### J2 Connector

- 5 vdc - Input - regulated 5 vdc @ 30ma
- Pullup +5V - Connection to pullup resistor 1k @ 5VDC
- Data 0 OUT - Open collector Wiegand data output
- Pullup +5V - Connection to pullup resistor 1k @ 5VDC
- Data 1 OUT - Open collector Wiegand data output
- Gnd - Output ground

#### Notes:

1. Input Ground and Output Ground are electrically isolated.
2. +5VDC (Regulated) is required to operate converter.

# CVX-OPTW

## Quick Start Guide



Previous versions of the CVX-OPTW had internal pullup resistors connected to the output ports. These pullup resistors were wired to the +5VDC supply. This newer version provides the option of connecting the pullup resistors in order to allow connection as a true open collector output.

With the pullup resistors connected as indicated in the above diagram, the new OPTW is equivalent to the previous version.

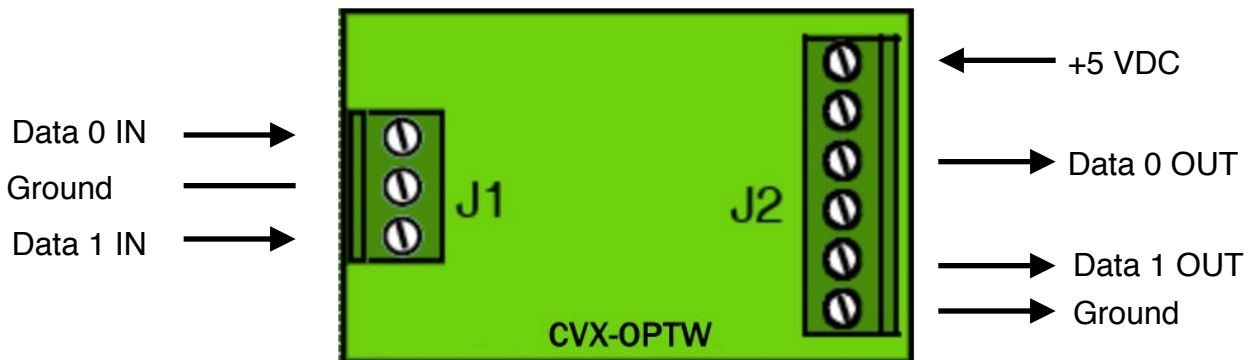

If voltage levels other than 5 volts are required at the output, then do not connect the internal pullup resistors. The outputs are now open collectors and will work with voltages from 5 to 24 VDC. Depending on the system, you may need pullup resistors to the higher voltage.

5VDC ONLY

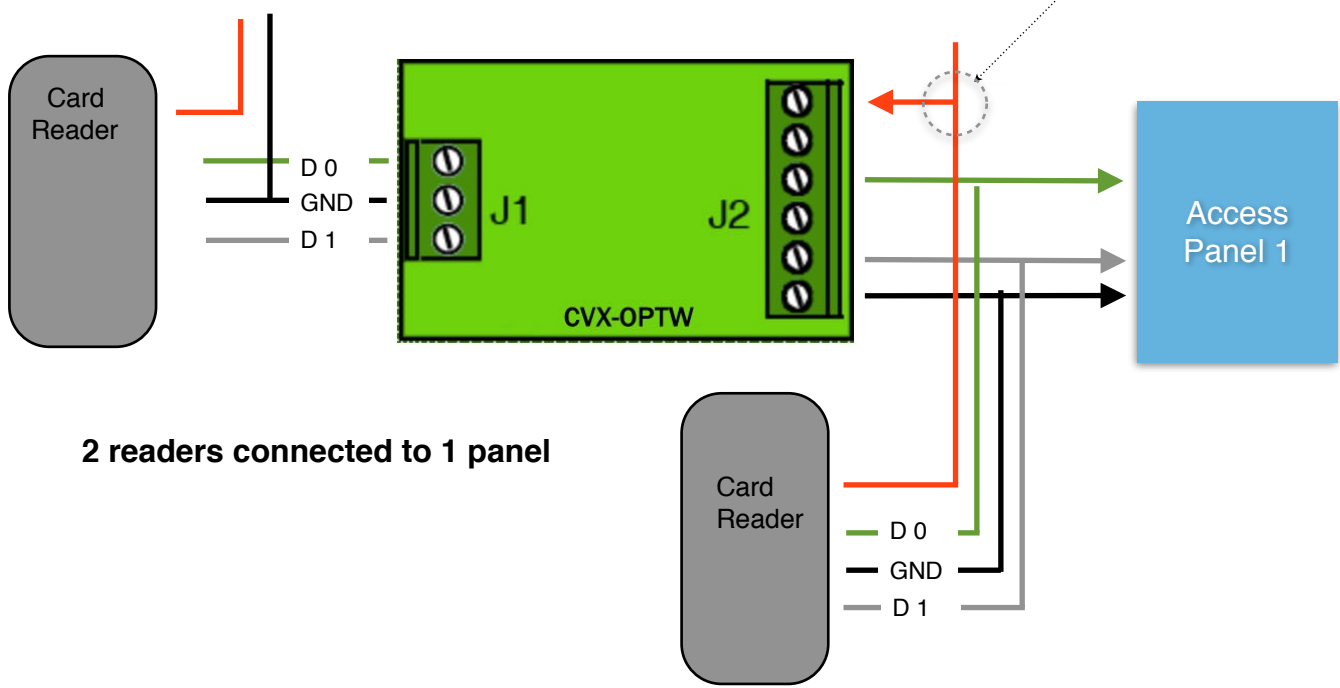

2 readers connected to 1 panel

5VDC ONLY

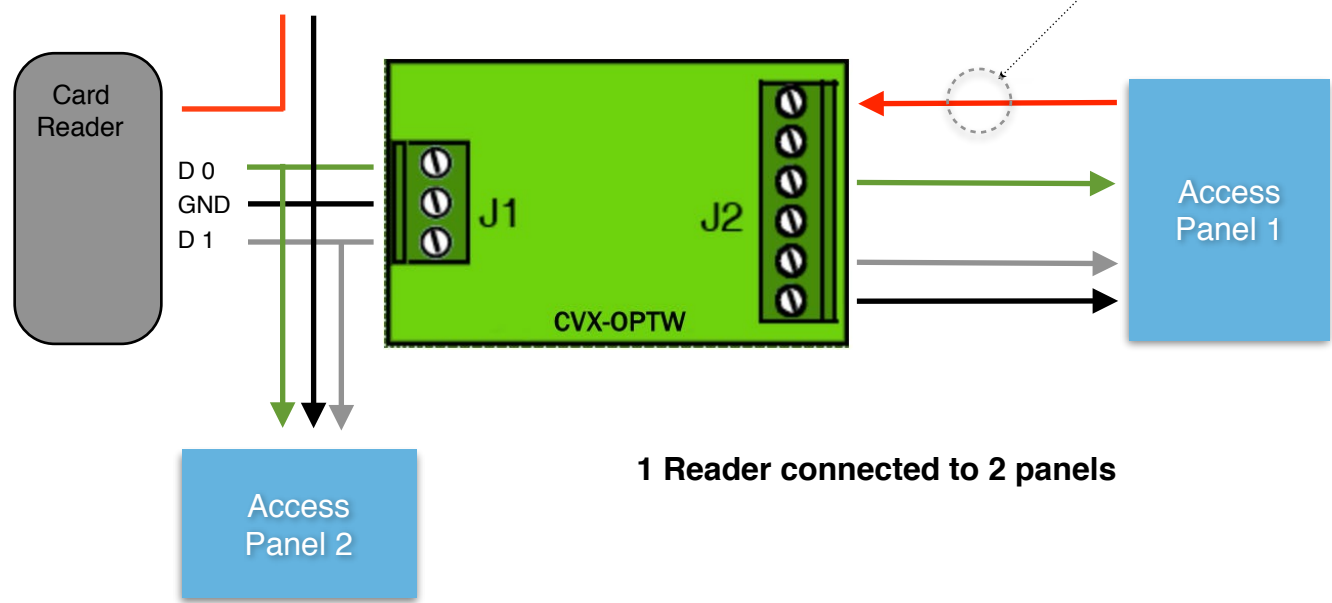

1 Reader connected to 2 panels

# 1 Reader connected to multiple panels

