

STI Universal Button



UB-1



UB-1/LTUL



PRODUCT OVERVIEW

This momentary button helps eliminate having to stock dozens of push buttons, and wasting precious time and money tracking down just the right button for a customer. It offers many options to provide just what a customer wants in one convenient package. Button is ready to be assembled out of box and is easily installed within minutes on site.

Universal Button offers over 300 different combinations for the price of a standard one configuration button. The faceplate is constructed of cast aluminum metal, allowing it to take tough knocks in stride, and is slightly oversized to cover old plate installation marks. Button package includes: faceplate, three illuminated push buttons, five changeable button messages and ten changeable illuminated activation messages.

HOW IT WORKS

The installer simply has to choose which lens cover, button insert and interchangeable message plate works best for the customers need, and easily snap them in place. This allows the button to be mounted in a matter of minutes instead of waiting weeks for a specific button to be ordered and delivered.

FEATURES

- Momentary button offers many options to provide just what a customer wants in one convenient package.
- Faceplate constructed of cast aluminum.
- Illuminated 12/24 volt LED button and illuminated message light kit.
- Two sets of independent Form "C" contacts.
- Contacts rated at 10A, 1/2 HP, 125/250 VAC, 6A, 30V.
- Temperature: -40° to 185° F (-40° to 85°C).
- UL Listed to U.S. and Canadian safety standards.
- 100,000 operations.
- Mounts to standard electrical handi box.
- Offers over 300 different combinations.
- Single gang plate slightly oversized to cover old plate installation marks.
- Five inserts for the button included – EXIT, PUSH, PUSH TO EXIT, handicap symbol and blank.
- Three different lens covers included – red, green and blue.
- Ten color coated message inserts in green, blue, yellow and white.
- Plate messages inscribed with EXIT, EMERGENCY and translucent blanks (allowing for custom labels).
- One year guarantee on electro mechanical and electronic components.

STI Universal Button

Dimensions and Technical Information

MODEL AVAILABLE

- UB-1 Universal Button
- UB-2 2" Universal Button
- UB-1/LTUL* Universal Button with UL Latching Timer
- UB-2/LTUL* 2" Universal Button with UL Latching Timer

Accessories

- LT-1 Latching/Timer Module
- UB-2LENS 2" Lens
- UB-1CL-Color Custom Label applied to blank, changeable message plates (blue, green, white or yellow)
- SUB-UB-1C Contact Block
- SUB-71102A-Color Color Match Back Box Kit (red, blue, green, white or yellow)
- 10147 24 Volt LED, White (standard)
- 10145 24 Volt LED, Red
- 10141 24 Volt LED, Blue
- 10143 24 Volt LED, Green
- 10144 12 Volt LED, Red
- 10140 12 Volt LED, Blue
- 10142 12 Volt LED, Green
- STI-6518 Bopper Stopper® Protective Cover
- STI-6600-Color Mini Stopper® II with Horn (blue, green, white or yellow)

*See LT-1 for complete latching/timer information

APPROVALS & WARRANTY

TESTING

It has been tested and approved or listed by:

- UL/cUL File S7255, Volume 2
- ADA for operation

WARRANTY

One year guarantee on electro mechanical and electronic components.

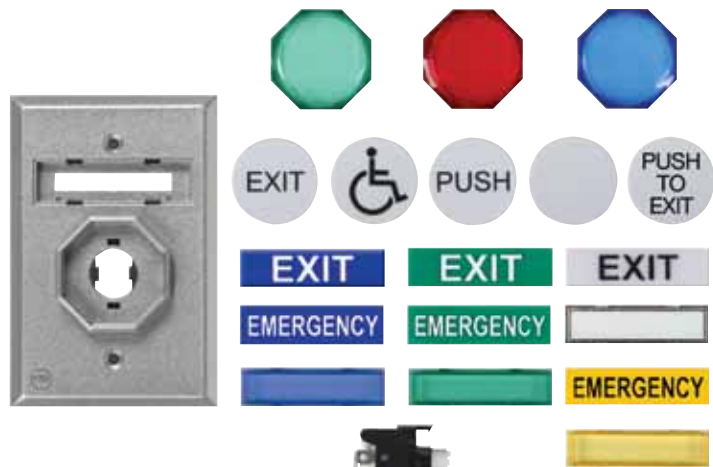

UB-2

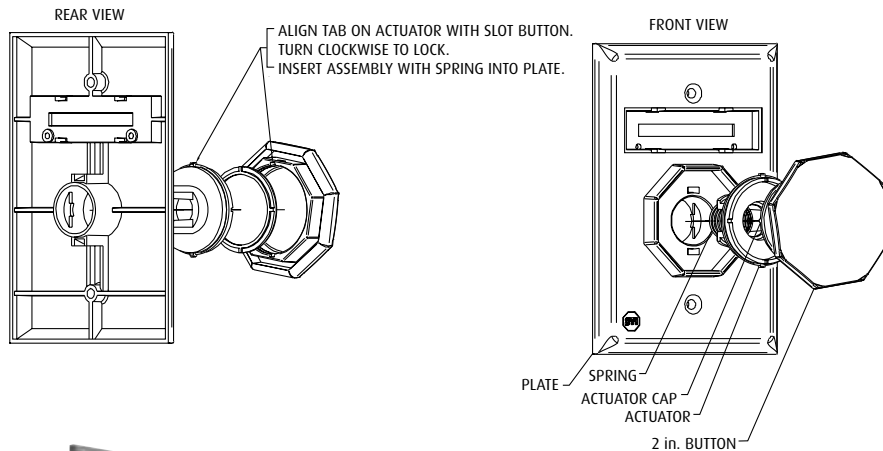

UB-1

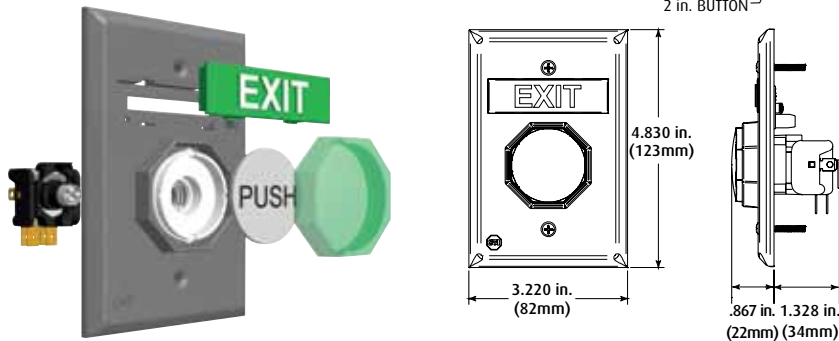

Safety Technology International, Inc.

2306 Airport Road
Waterford, Michigan
48327, USA

Tel: 248-673-9898
Fax: 248-673-1246
Toll-free: 800-888-4784
info@sti-usa.com
www.sti-usa.com

Unit 49G Pipers Road
Park Farm Industrial Estate
Redditch, Worcestershire
B98 0HU England

Tel: 44 (0) 1527 520 999
Fax: 44 (0) 1527 501 999
Free: 0800 085 1678 (UK)
www.sti-europe.com