

STI Light Damage Stoppers®



STI-9702



STI-9796



STI-9703

PRODUCT OVERVIEW

Here is an excellent way to protect your Hubbell Superbay and outdoor lights against vandalism and accidental damage. These Stoppers were created in response to multiple requests from STI customers. They are easy to install with all fasteners provided. STI-9702 and STI-9709 guards bolt directly to the transformer (not the reflective lens like most other guards) providing more strength to protect the expensive reflector. Light bulb replacement is easy without the removal of the guard.

BACKED BY A THREE YEAR GUARANTEE

Constructed of tough, 9-gauge steel wire that is coated with corrosion resistant white polyester. It is not surprising STI backs them with a three year guarantee against breakage in normal use. These Stoppers are highly recommended for areas where abuse is severe or it is imperative lights continue to operate.

FEATURES

- Offers protection against vandalism and accidental damage for warehouse or sport facility lights.
- Constructed of tough 9-gauge steel wire.
- Installation is fast and simple with screws and nuts provided.
- Guard bolts directly to the transformer (not the reflective lens like most other guards) providing more strength to protect the expensive reflector.
- Fits reflector mounting kit in all positions.
- Coated with corrosion resistant polyester.
- Easy light bulb replacement without removal of guard.
- STI-9702 fits 3 Hubbell models: WA-22, WD-22 and BL-WA22.
- STI-9709 fits existing Hubbell WA25 series.
- STI-9796 is designed to protect Lithonia Lighting TBD 175MV 120 PKG.
- Three year guarantee against breakage in normal use.

STI Light Damage Stoppers®

Dimensions and Technical Information

MODELS AVAILABLE

STI-9702 Bay Light Damage Stopper® for Hubbell® Superbay Lights

STI-9703 Light Damage Stopper®

STI-9709* Bay Light Damage Stopper®

STI-9797 Outdoor Light Damage Stopper®

*NOTE: Allow 8 to 10 weeks for delivery.

Other Related Models

- Steel Web Stoppers® for smoke detectors (STI-9601 series)
- Clock/Bell Damage Stopper® (STI-9631, STI-9632, STI-9633)
- Motion Detector Damage Stopper® (STI-9618, STI-9619, STI-9620, STI-9621, STI-9622)
- Smoke Beam Guard (STI-9623, STI-9625)
- Emergency Light Damage Stopper® (STI-9649)
- Fluorescent Light Damage Stopper® (STI-9651)

Approximate Weight

STI-9702 7.75 lbs.

STI-9709 14.5 lbs.

WARRANTY

Three year guarantee against breakage in normal use.

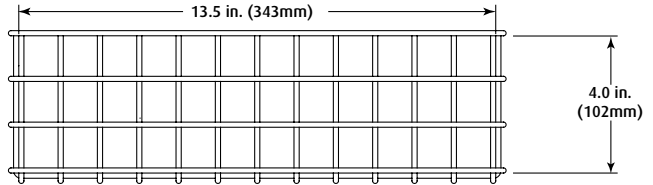

TOP VIEW

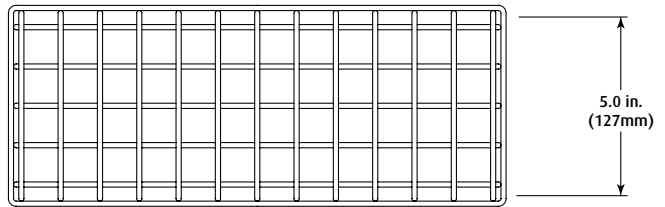

FRONT VIEW

STI-9703

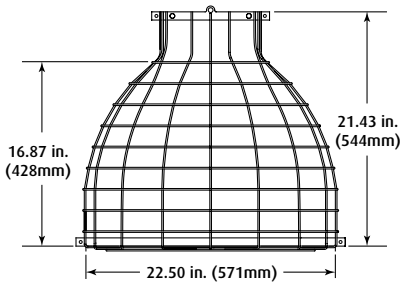

STI-9702

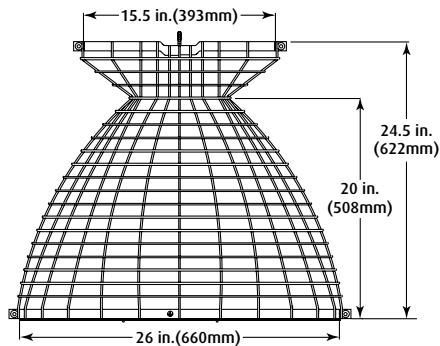

STI-9709

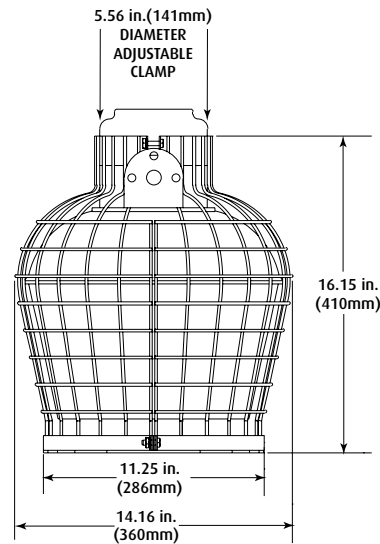

STI-9796



Safety Technology International, Inc.

2306 Airport Road
Waterford, Michigan
48327, USA

Tel: 248-673-9898
Fax: 248-673-1246
Tollfree: 800-888-4784
info@sti-usa.com
www.sti-usa.com

Unit 49G Pipers Road
Park Farm Industrial Estate
Redditch, Worcestershire
B98 0HU England

Tel: 44 (0) 1527 520 999
Fax: 44 (0) 1527 501 999
Free: 0800 085 1678 (UK)
www.sti-europe.com