

**C**

► Models 154XSTHI and 154XST-024C-CN

## Hazardous Location Supervised Strobe Lights

These models are hazardous location strobe lights that provide 60 high-intensity flashes per minute. This warning light is available in 24VDC with a 4-wire supervisable power circuit for fire alarm and suppression supervised control panels.

These warning lights offer an aluminum base, coated for corrosion resistance that is ready for mounting on a 3/4-inch pipe. The dome guard (included) fits over the glass dome to protect it against accidental collision with moving equipment, such as forklifts.

These rugged strobe warning lights are specifically designed for hazardous locations or corrosive environments where a very bright visual signal is required. This warning light can be used for plant evacuation or other communication needs.

### FEATURES

- Available in 24VDC
- Four wires and supervisory diode
- Clear dome
- 3/4-inch pipe mount
- Dome guard included
- Conformal coated PCBA
- Type 4X, IP66 enclosure
- IP69K compliant
- Marine Rated
- UL Listed for Class I, Division 2, Groups A, B, C and D; Class II, Division 1, Groups E, F, and G; Class III
- 154XSTHI is UL Fire Listed
- 154XST-024C-CN is ULC Fire Listed

MODEL	VOLTAGE	CURRENT DRAW	FLASH RATE/ MINUTE	CANDELA EFFECTIVE
<b>154XSTHI</b> <b>154XST-024C-CN</b>	24VDC (regulated 16V-33V)	(0.483 amps – 0.226 amps)	60	17 cd with guard 25 cd without guard

### HAZARDOUS LOCATION RATING: 154XSTHI and 154XST-024C-CN

T-CODE AT MAXIMUM AMBIENT TEMPERATURE, °C

HAZARDOUS LOCATION	40°C
Class I, Division 2, Groups A, B, C, D	T4
Class II, Division 1, Groups E, F, G	T5
Class III	T5

## Hazardous Location Supervised Strobe Lights (154XSTHI and 154XST-024C-CN)

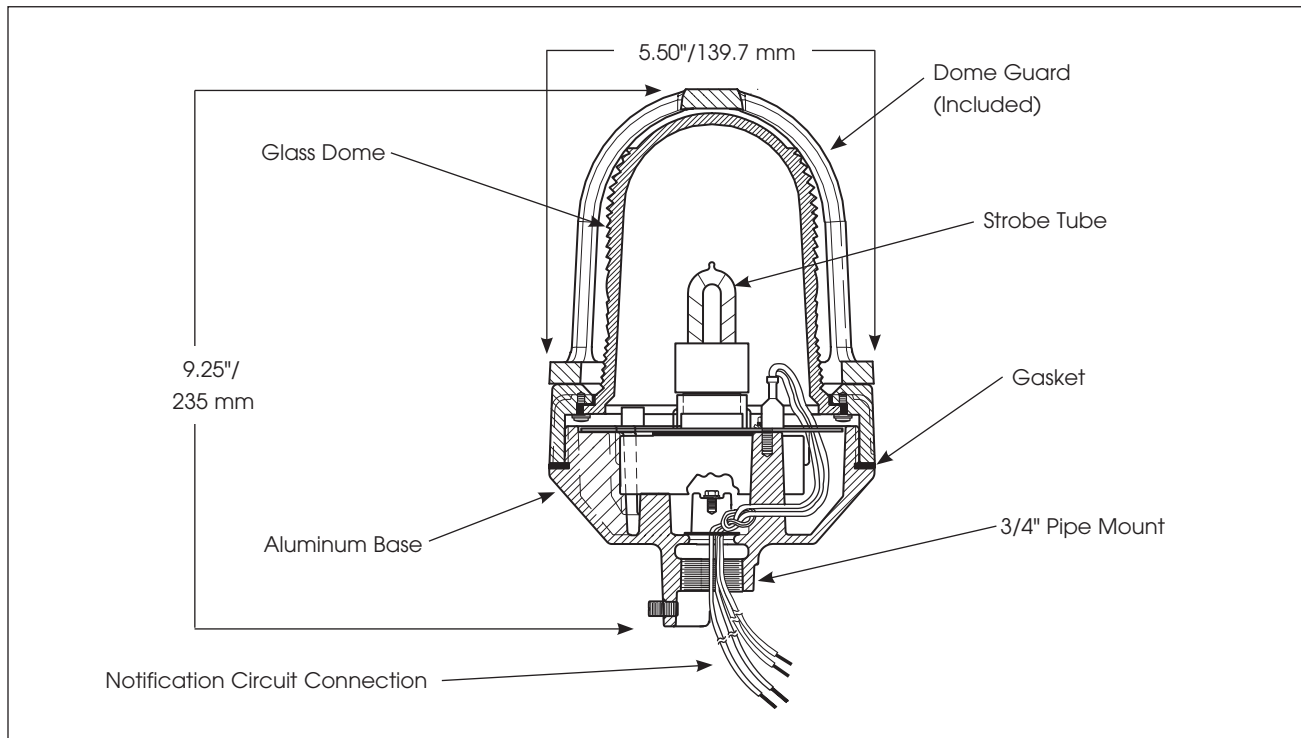

### SPECIFICATIONS

Lamp Life <sup>1</sup> :	10,000 Hours	
Lamp Source	Strobe	
Operating Ambient Temperature:	-67°F to 150°F	-55°C to 66°C
Net Weight:	3.8 lbs	1.7 kg
Shipping Weight:	4.5 lbs	2.0 kg
Height:	9.25"	235 mm
Diameter:	5.50"	139.7 mm

<sup>1</sup> Optimal hours under ideal conditions.

### REPLACEMENT PARTS \*

Description	Part Number
Strobe Tube	K149122B
Dome Guard, Red	K8449090C-01
Dome Guard, Black	K8449090C

\* ULC prohibits any field servicing of hazardous location products. Part numbers are for reference only.

### HOW TO ORDER

#### Specify Model:

**154XSTHI** – UL Fire Listed Strobe, 24VDC, hazardous location, 4-wire, clear

**154XST-024C-CN** – ULC Fire Listed Strobe, 24VDC, hazardous location, 4-wire, clear