

# WIRELESS KEYPAD KPW250

SECTION 28 13 00



## KEY FEATURES

<b>UNIT INTERFACE CAPABILITIES</b>	PIN
<b>STAND ALONE</b>	Yes
<b>WIRELESS COMMUNICATION</b>	Yes*

## SPECIFICATIONS

<b>POWER SUPPLY</b>	9V Lithium battery (included in carton)
<b>PROGRAMMING (DATABASE MANAGEMENT)</b>	Keypad
<b>LOCAL USER CAPACITY</b>	250
<b>MAX NUMBER OF GATES/DOORS OF CONTROL (EACH)</b>	1
<b>RELAY OUTPUT</b>	1
<b>MOUNTING OPTIONS</b>	Surface/gooseneck
<b>OPERATING TEMPERATURE</b>	-4°F to 140°F (-20°C to 60°C)
<b>CAMERA READY</b>	No
<b>ANTI-TAMPER ALARM</b>	No
<b>WARRANTY</b>	1 year

## CONSTRUCTION

<b>ENCLOSURE MATERIAL</b>	Zinc-alloy cover/polycarbonate back
---------------------------	-------------------------------------

\*When used with LiftMaster® operators with Security+ 2.0® Radio

**DATA SHEET**  
WIRELESS KEYPAD

**LiftMaster®**

# WIRELESS KEYPAD KPW250

SECTION 28 13 00

## DIMENSIONS

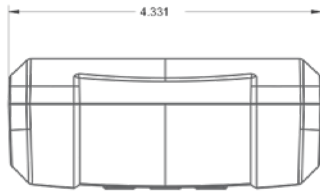

TOP

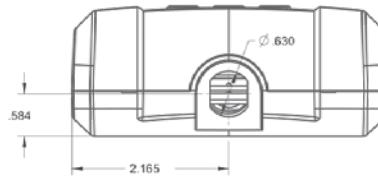

BOTTOM

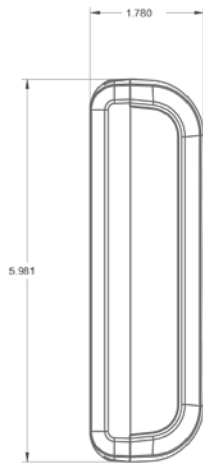

LEFT

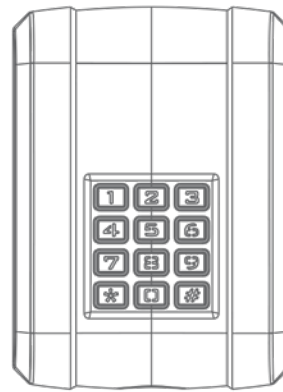

FRONT

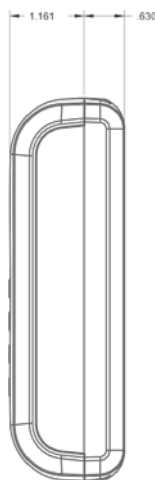

RIGHT

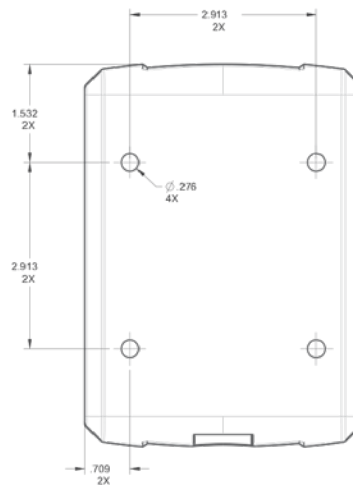

REAR